

RULES

FOR TECHNICAL SUPERVISION DURING CONSTRUCTION OF SHIPS AND MANUFACTURE OF MATERIALS AND PRODUCTS FOR SHIPS

ND No. 2-020101-175-E

RULE CHANGE NOTICE

ENTERS INTO FORCE:

01.01.2025



St. Petersburg
2024

RULES FOR TECHNICAL SUPERVISION DURING CONSTRUCTION OF SHIPS AND MANUFACTURE OF MATERIALS AND PRODUCTS FOR SHIPS

The present Rule Change Notice to the Rules for Technical Supervision during Construction of Ships and Manufacture of Materials and Products for Ships (hereinafter — RCN) has been approved in accordance with the established approval procedure, comes into force on 1 January 2025 and contains earlier approved amendments published by the Urgent Rule Change Notices after entering into force of the previous version of the Rules for Technical Supervision during Construction of Ships and Manufacture of Materials and Products for Ships (these amendments are specified in the Revision History and highlighted in yellow).

REVISION HISTORY

PART I. GENERAL REGULATIONS FOR TECHNICAL SUPERVISION

Item	Applicability	Description	Remarks
Para 10.3.1.1	Recognition of testing laboratories Special requirements for testing laboratories engaged in non-destructive testing (NDT) of materials, products, weld quality	New types of non-destructive testing — ANDT and AUT, have been introduced	IACS UR W35 (Rev.1 Oct 2023)
Para 10.3.1.2	Recognition of testing laboratories Special requirements for testing laboratories engaged in non-destructive testing (NDT) of materials, products, weld quality	References to ISO 9712:2021, SNT-TC-1A, 2020 and ANSI/ASNT CP-189, 2020 have been updated	IACS UR W35 (Rev.1 Oct 2023)
Para 10.3.1.4.9	Recognition of testing laboratories Special requirements for testing laboratories engaged in non-destructive testing (NDT) of materials, products, weld quality	Reference to ISO 9712:2021 has been updated	IACS UR W35 (Rev.1 Oct 2023)
Para 10.3.1.5	Recognition of testing laboratories Special requirements for testing laboratories engaged in non-destructive testing (NDT) of materials, products, weld quality	Information has been introduced on the requirements for quality management system of testing laboratories regarding Type C inspection body	IACS UR W35 (Rev.1 Oct 2023)

*Rules for Technical Supervision during Construction of Ships
and Manufacture of Materials and Products for Ships*

Item	Applicability	Description	Remarks
Table 12.1.1	Recognition of firms' conformity Kinds of activity	New code 22025000 — Verification of cyber security of onboard computer based systems (CBS) and networks has been introduced	
Para 12.2.9.3 (new)	Recognition of firms' conformity Requirements for firms	Requirements for issuance by the Register of a short-term certificated have been introduced	
Para 12.3.5 (new)	Recognition of firms' conformity Special requirements	Special requirements for a firm with kind of activity "Verification of cyber security of onboard computer based systems (CBS) and networks" have been introduced	
Appendix 1 , codes 05140350MK and 05140360MK (new)	Navigational equipment GNSS receiver (Beidou) IRNSS receiver	RS Nomenclature has been supplemented with new navigational equipment	
Appendix 1 , code 05410000	Navigational equipment Cyber safety equipment for radio and navigational equipment	Name of item of technical supervision in the RS Nomenclature code has been replaced by "Equipment of 460-network"	
Appendix 1 , codes 1514000 and 15141000 (deleted)	Cyber security Cyber safety equipment for control and automation systems	Codes have been deleted in full	

PART II. TECHNICAL DOCUMENTATION

Item	Applicability	Description	Remarks
Para 4.1.1	Technical documentation Distribution of authority to review technical documentation on ships	Requirement for obtaining RHO authorization for review of projects involving major conversions of ships, ship passage plans has been excluded	Circular Letter No. 311-05-1986c of 28.12.2023
Para 4.3	Technical documentation on ships	Instructions on applicability of the requirements of the RS Rules have been replaced with the reference to para 1.3.2.2 of the General Regulations for the Classification and Other Activity. It has been introduced that the applicability criteria for the requirements of international documents are defined in the international documents themselves	
Appendix 1, Table 1	Operational documentation for recycling	The item name has been amended. Compliance of the inventory of hazardous materials shall be endorsed by a stamp that reads "Agreed". Reference to Part III "Survey of ships in compliance with international conventions, codes, resolutions and Rules for the Equipment of Sea-Going Ships" of the Guidelines on Technical Supervision of Ships in Service has been changed	

*Rules for Technical Supervision during Construction of Ships
and Manufacture of Materials and Products for Ships*

Item	Applicability	Description	Remarks
Para 12.3.2.4	Software Report for renewal of the Type Approval Certificate for Software (СТОП)	The Report (form 6.3.10) is replaced with the Report (form 6.3.29)	
Appendix 1, Table 1, Section 44	Ships and offshore installations Operational documentation	In view of publication of the new Part XXI "Cyber Resilience" The list of documentation for cyber safety has been replaced by that for cyber resilience	Entry-into-force date: 02.07.2024 (Urgent Rule Change Notice No. 311-05-2017 of 02.07.2024)

PART III. TECHNICAL SUPERVISION DURING MANUFACTURE OF MATERIALS

Item	Applicability	Description	Remarks
Para 6.1.1	Welding Approval of welding procedures Welding Procedure Approval Test Certificate	Para has been amended regarding confirming document issued by RS during approval of welding procedure	
Para 6.1.2	Welding Approval of welding procedures Pre-production welding tests	Approval application has been indicated. Application of welding procedure approval schemes has been specified	IACS UR W28 (Rev.2 Mar 2012)

*Rules for Technical Supervision during Construction of Ships
and Manufacture of Materials and Products for Ships*

Item	Applicability	Description	Remarks
Para 6.1.3	Welding Approval of welding procedures Requirements of national and international standards	Application conditions have been specified	
Para 6.1.5	Welding Approval of welding procedures Testing during production	Para has been supplemented by friction stir welding process	
Para 6.1.6 (new)	Welding Approval of welding procedures Scope of requirement application	New para has been introduced restricting application of requirements of the Section	IACS UR W28 (Rev.2 Mar 2012)
Para 6.2.1	Welding Approval of welding procedures Definitional of welding procedure	Terminology has been amended in accordance with IACS Unified Requirement	IACS UR W28 (Rev.2 Mar 2012)
Para 6.2.2.3	Welding Approval of welding procedures Types of welds	Terminology has been specified regarding types of welds and their designations	IACS UR W28 (Rev.2 Mar 2012)
Para 6.2.2.5	Welding Approval of welding procedures Applicable welding processes in protective gases	Welding processes applied in shipbuilding have been specified	
Para 6.3.1.1.2	Welding Approval of welding procedures Tekken test pieces	Requirements for number of Tekken test pieces for types of welding have been deleted and transferred to 6.3.1.7	

*Rules for Technical Supervision during Construction of Ships
and Manufacture of Materials and Products for Ships*

Item	Applicability	Description	Remarks
Para 6.3.1.2	Welding Approval of welding procedures Test piece for butt-welded joint	Note has been deleted	IACS UR W28 (Rev.2 Mar 2012)
Para 6.3.1.4	Welding Approval of welding procedures T-joint test piece without edge preparation	Note has been deleted	IACS UR W28 (Rev.2 Mar 2012)
Para 6.3.1.5	Welding Approval of welding procedures Corner, tee (T-) and cruciform joints fillet-welded in plate	Conditions for T-joint test piece welding with full penetration have been amended	IACS UR W28 (Rev.2 Mar 2012)
Para 6.3.1.6	Welding Approval of welding procedures Welding of test piece for pipe and branch connections	Condition for welding of such test pieces during approval of welding procedures has been indicated. Condition for selection of angle of branch welded to the pipe has been specified	6.2.4 ISO 15614-1
Para 6.3.1.7	Welding Approval of welding procedures Tekken test pieces	Para has been supplemented with requirements for number of Tekken test pieces for types of welding transferred from 6.3.1.1.2	
Para 6.3.2.1.3	Welding Approval of welding procedures Test piece welded in two directions	Conditions allowing welding of one test piece in two directions (flat and overhead) have been specified	IACS UR W28 (Rev.2 Mar 2012)

*Rules for Technical Supervision during Construction of Ships
and Manufacture of Materials and Products for Ships*

Item	Applicability	Description	Remarks
Para 6.3.2.2.5	Welding Approval of welding procedures Welding of test pieces	Performance conditions have been specified	IACS UR W28 (Rev.2 Mar 2012)
Table 6.4.1.1	Welding Approval of welding procedures Requirements for scope of testing	Requirements for T-joints in plate with full penetration have been deleted	IACS UR W28 (Rev.2 Mar 2012)
Para 6.4.1.2	Welding Approval of welding procedures Brittle crack arrest (BCA) steel	Wording has been specified	IACS UR W31 (Rev.2 Dec 2019)
Para 6.4.4.1	Welding Approval of welding procedures Mechanical tests Tensile test	Para has been supplemented by provisions of deleted para 6.4.4.7.1 and relevant provisions of IACS UR W28. Values of mechanical properties of test pieces regarding assessment of results given in Table 6.4.4.1.1 supplemented by a column "Consumable quality grade" have been specified	IACS UR W28 (Rev.2 Mar 2012)
Para 6.4.4.2	Welding Approval of welding procedures Mechanical tests Bend test	Para has been supplemented with provisions of deleted para 6.4.4.7.2	

*Rules for Technical Supervision during Construction of Ships
and Manufacture of Materials and Products for Ships*

Item	Applicability	Description	Remarks
Para 6.4.4.3	Welding Approval of welding procedures Mechanical tests Fracture test	Para has been supplemented by provisions of deleted para 6.4.4.7.3	
Para 6.4.4.4	Welding Approval of welding procedures Mechanical tests Impact test	Table to Fig. 6.4.4.4-1 has been additionally supplemented by non-full scale test piece with 2,5 mm in height. Para has been supplemented by provisions of deleted para 6.4.4.7.4	
Para 6.4.4.5	Welding Approval of welding procedures Hardness measurement	Para has been supplemented by explanation for EH47 steel and steel with indices "BCA1" and "BCA2" given in para and provisions of deleted para 6.4.4.7.5	IACS UR W31 (Rev.2 Dec 2019)
Para 6.4.4.6	Welding Approval of welding procedures Macro examination	Para has been supplemented by provisions of deleted para 6.4.4.7.6	
Para 6.4.4.7 (deleted)	Welding Approval of welding procedures Requirements for estimation of mechanical test results	Provisions of para 6.4.4.7 have been distributed among paras 6.4.4.1 — 6.4.4.6 according to the types of mechanical tests. Existing para 6.4.4.8 has been renumbered 6.4.4.7	IACS UR W28 (Rev.2 Mar 2012)

*Rules for Technical Supervision during Construction of Ships
and Manufacture of Materials and Products for Ships*

Item	Applicability	Description	Remarks
Para 6.6.1.6 (deleted)	Welding Approval of welding procedures Range of approval for steels with indices BCA1 and BCA2	Provisions of para have been transferred to 6.6.2 (para 6.6.2.1.6) and supplemented by explanation for steels with indices "BCA1" and "BCA2" given in para	IACS UR W31 (Rev.2 Dec 2019)
Table 6.6.2.2.2	Welding Approval of welding procedures Requirements for the range of approval for thickness of base metal	Name of Table has been specified. Technical terminology has been specified	
Para 6.6.2.2.6	Welding Approval of welding procedures Limitation of the range of approval for maximum thickness regarding exceeding hardness values	Wording has been specified	
Para 6.6.2.2.10	Welding Approval of welding procedures Range of approval of welding procedures on angles of branch connections	Reference to new para 6.6.3.3.3 has been introduced regulating the scope of approval for angles of branches welded to the pipe	
Para 6.6.3.2	Welding Approval of welding procedures Range of approval of welding processes regarding welding positions	Welding positions have been specified which are covered by the range of approval	IACS UR W28 (Rev.2 Mar 2012)

*Rules for Technical Supervision during Construction of Ships
and Manufacture of Materials and Products for Ships*

Item	Applicability	Description	Remarks
Para 6.6.3.3.3 (new)	Welding Approval of welding procedures Range of approval of welding procedures on angles of branch connections	New para has been introduced regulating the scope of approval on angles of branched welded to the pipe	ISO 15614-1
Para 6.6.3.3.7 (new)	Welding Approval of welding procedures Range of approval of welding process	New para has been introduced regulation the range of approval according to the type of welding of C welds	IACS UR W28 (Rev.2 Mar 2012)
Para 6.6.3.4.2	Welding Approval of welding procedures Range of approval of welding consumables according to their classification and manufacturer	Terminology has been specified	IACS UR W28 (Rev.2 Mar 2012)
Para 6.6.4.3	Welding Approval of welding procedures Requirements for the range of approval for tungsten inert gas welding	Terminology has been specified (names of welding processes)	ISO 4063
Para 6.7.5	Welding Approval of welding procedures Additional requirements for YP47 steel	Wording of para 6.7.5.1 has been specified regarding CTOD testing. New paras 6.7.5.2 — 6.7.5.4 have been introduced regarding performance of other mechanical tests of test pieces required for YP47 steel	IACS UR W31 (Rev.2 Dec 2019)

*Rules for Technical Supervision during Construction of Ships
and Manufacture of Materials and Products for Ships*

Item	Applicability	Description	Remarks
Para 6.8.3.4	Welding Approval of welding procedures COTPC confirmation	Period for confirmation has been amended from 2,5 to 2 years	
Para 7.1.3	Welding Approval of welding procedures of aluminium alloys	Terminology has been specified	

PART IV. TECHNICAL SUPERVISION DURING MANUFACTURE OF PRODUCTS

Item	Applicability	Description	Remarks
Para 3.5.1.1	Sea-Going Ships Super High Holding Power (SHHP) Anchors	The requirements for the application of the technical supervision have been specified	
Section 3, Appendix 3, para 3	Sea-Going Ships Anchors Anchor Shackle	Scope of the anchor shackle testing has been specified	
Section 5, Appendix 6	Internal combustion engines Gas Internal combustion engines Type testing approval	All types of diesel engines supplied with low pressure gaseous methane, have been specified	UR IACS M78 (Rev.2 Jan 2024)

*Rules for Technical Supervision during Construction of Ships
and Manufacture of Materials and Products for Ships*

Item	Applicability	Description	Remarks
Section 5, Appendix 7	Internal combustion engines Gas Internal combustion engines Bench tests (factory acceptance tests (FAT)) and tests after installation on board the ship	Testing requirements have been introduced for ICE fuelled by natural gas	UR IACS M78 (Rev.2 Jan 2024)
Section 5, Appendix 8	Internal combustion engines Gas Internal combustion engines Documentation for ICE components	Summary of required documentation for ICE (fuelled by natural gas) components has been added	UR IACS M78 (Rev.2 Jan 2024)
Table 8.5.4.4	Ships under Construction Joint Types Test Program	Applicability of requirements for testing pipeline joints has been specified	UR P2.11 (Rev.5 Oct 2023)
Para 10.1.4 (new)	On-board computer based systems (CBS) with codes 11100000 — 11120000 Technical documentation and cyber resilience testing	Requirements for technical documentation and cyber resilience testing have been introduced	Entry-into-force date: 02.07.2024 (Urgent Rule Change Notice No. 311-05-2018 of 02.07.2024)
Para 10.7.17.3.3	Electrical Equipment Items and devices for installation, splicing and connection of cables and wires Flame retardant test	Requirements for tests have been aligned with the current international standard	IEC 60695-11-5:2017

*Rules for Technical Supervision during Construction of Ships
and Manufacture of Materials and Products for Ships*

Item	Applicability	Description	Remarks
Table 12.3.2-1	Sea-Going Ships Automation Equipment Technical Documentation	A new technical documentation code on cyber resilience has been introduced. The title and description of technical documentation with code C1 has been specified	Entry-into-force date: 05.07.2024 (Urgent Rule Change Notice No. 311-05-2020 of 05.07.2024)
Table 12.6	Sea-Going Ships Automation Equipment Tests and Checks	New cyber resilience test code has been introduced	Entry-into-force date: 05.07.2024 (Urgent Rule Change Notice No. 311-05-2020 of 05.07.2024)
Para 12.6.19 (new)	Sea-Going Ships Automation Equipment Cyber Resilience Testing	Requirements for cyber resilience testing have been introduced	Entry-into-force date: 05.07.2024 (Urgent Rule Change Notice No. 311-05-2020 of 05.07.2024)
Appendix 1, Table 1	Sea-Going Ships Automation Equipment Technical Documentation and Tests	The Table has been supplemented by a new code for technical documentation on cyber resilience and a new code for testing for cyber resilience	Entry-into-force date: 05.07.2024 (Urgent Rule Change Notice No. 311-05-2020 of 05.07.2024)

*Rules for Technical Supervision during Construction of Ships
and Manufacture of Materials and Products for Ships*

Item	Applicability	Description	Remarks
Appendix 3 (recommended), check-list	Sea-Going Ships Automation Equipment Technical Documentation	The check-list has been supplemented by a new code and technical documentation on cyber resilience. The name of technical documentation with code C1 has been specified	Entry-into-force date: 05.07.2024 (Urgent Rule Change Notice No. 311-05-2020 of 05.07.2024)
Appendix 4 (recommended), check-list	Sea-Going Ships Automation Equipment Tests	The check-list has been supplemented by a new cyber resilience testing code	Entry-into-force date: 05.07.2024 (Urgent Rule Change Notice No. 311-05-2020 of 05.07.2024)
Table 17.3.1.1	Survey of items of technical supervision Washing machines Garbage receptacles Oil/water interface detectors Ventilation equipment	Names of items of technical supervision have been amended. List of actions for equipment verification and testing has been supplemented	
Para 17.3.1.8	Survey of items of technical supervision Drawing up of Type/Test Approval Certificates (СТО, СОТО, СОТИ)	Requirements containing duplicating information have been deleted	
Para 17.3.2.4	Survey of items of technical supervision Oily water fine cleaning systems	Name of item of technical supervision has been amended. List of requirements for verification has been supplemented	
Para 17.3.3.2 (deleted)	Survey of items of technical supervision Alarms of oily water fine cleaning systems	Requirements containing duplicating information have been deleted	

*Rules for Technical Supervision during Construction of Ships
and Manufacture of Materials and Products for Ships*

Item	Applicability	Description	Remarks
Para 17.3.6	Survey of items of technical supervision Washing machines	Para has been renamed for clear description of applicability	
Para 17.3.10	Survey of items of technical supervision Sewage treatment plants	Para has been renamed for clear description of applicability	
Paras 17.3.14 and 17.3.14.1 (new)	Survey of items of technical supervision Survey of garbage receptacles	Existing requirements of paras 17.3.19 and 17.3.19.1 have been transferred. Paras 17.3.14, 17.3.14.1, 17.3.15, 17.3.15.1, 17.3.16, 17.3.16.1, 17.3.16.2, 17.3.17, 17.3.18 and 17.3.18.1 and references thereto have been renumbered 17.3.15, 17.3.15.1, 17.3.16, 17.3.16.1, 17.3.17, 17.3.17.1, 17.3.17.2, 17.3.18, 17.3.19 and 17.3.19.1 accordingly	
Paras 17.3.19 and 17.3.19.1 (deleted)	Survey of items of technical supervision Survey of garbage receptacles	Requirements have been transferred to new paras 17.3.14 and 17.3.14.1	
Para 17.3.18.1 (renumbered 17.3.19.1)	Survey of items of technical supervision Fuel sampling equipment	Reference to applicable IMO guidelines has been introduced	IMO circular MSC-MEPC.2/Circ.18
Appendix 2, paras 1, 3.1 and 3.2	Type/Test Approval Certificates (COTO/COTI)	References to the forms of the Register certificates have been updated	
Appendix 3 (deleted)	Type/Test Approval Certificates (COTO/COTI)	Appendix has been deleted as being no longer relevant	

*Rules for Technical Supervision during Construction of Ships
and Manufacture of Materials and Products for Ships*

18

Item	Applicability	Description	Remarks
Section 18 (deleted)	Sea-Going Ships Cyber Safety Equipment and Systems	The Section has been deleted due to transfer of the requirements to Section 12	Entry-into-force date: 05.07.2024 (Urgent Rule Change Notice No. 311-05-2020 of 05.07.2024)

PART I. GENERAL REGULATIONS FOR TECHNICAL SUPERVISION

10 RECOGNITION OF TESTING LABORATORIES

10.3 SPECIAL REQUIREMENTS

Paras 10.3.1, 10.3.1.1 and 10.3.1.2 are amended as follows:

"10.3.1 Special requirements for testing laboratories engaged in non-destructive testing (NDT/~~ANDT~~) of materials, products, weld quality (code 21001700).

10.3.1.1 Abbreviations.

For the purpose of this Chapter, the following abbreviations apply:

NDT — non-destructive testing. Comprising, but not limited to the methods and techniques VT, MT, PT, RT, ~~RT-D~~, UT, PAUT, ~~TOFD~~, ET and/or ACFM.

ANDT — advanced non-destructive testing. Comprising methods and techniques RT-D, PAUT, TOFD and AUT.

VT — visual testing.

MT — magnetic particle testing.

PT — penetrant testing.

RT — radiographic testing.

RT-D — digital radiography (computed radiography using storage phosphor imaging plates (RT-CR) or digital detector array radiography (DDA)).

UT — ultrasonic testing.

PAUT — phased array ultrasonic testing (technique within the method UT).

AUT — automated ultrasonic testing. A technique by which an object is tested by ultrasound using probes operating under mechanical control and where ultrasonic data is collected automatically (technique within the method UT).

TOFD — time of flight diffraction (technique within the method UT).

ET — electromagnetic testing (i.e. eddy current testing and/or alternating current field measurements [ACFM]).

10.3.1.2 Personnel.

Non-destructive testing (NDT) and quality assessment shall be performed by the specialists who have passed the appropriate training, have the proper qualification and practical experience in a particular NDT method which shall be documented.

The testing laboratory shall document that it has the competence and control needed to perform the specified services.

The testing laboratory is responsible for the qualification and preferably third party certification of its supervisors and operators to a recognised certification scheme based on ISO 9712:~~2012~~2021.

Personnel qualification to an employer based qualification scheme as e.g. SNT-TC-1A, ~~2016~~2020 or ANSI/ASNT CP-189, ~~2016~~2020 may be accepted if the testing laboratory's written practice is reviewed and found acceptable. The testing laboratory's written practice shall as a minimum, except for the impartiality requirements of a certification body and/or authorised body, comply with ISO 9712:~~2012~~2021.

The supervisors' and operators' certificates and competence shall comprise all industrial sectors and techniques being applied by the testing laboratory.

Level 3 personnel shall be certified by an accredited certification body."

Para 10.3.1.4.9 is amended as follows:

".9 a list of documented training and experience for NDT operators within the relevant service area, including qualifications and third party certification per ISO 9712:~~2012~~2021 based certification schemes;"

Para 10.3.1.5. The **last paragraph** is amended as follows:

"A documented quality system complying with the most current version of ISO/IEC 17020:2012 and including the above ~~would~~will be considered acceptable. The testing laboratory ~~should~~shall satisfy the requirements of Type A ~~or~~, Type B or Type C inspection body, as described in ISO/IEC 17020:2012."

12 RECOGNITION OF FIRMS' (ORGANIZATIONS') CONFORMITY

12.1 GENERAL

Table 12.1.1 is supplemented by **new code 22025000** reading as follows:

"

22025000	Verification of cyber security of onboard computer based systems (CBS) and networks
----------	---

"

12.2 REQUIREMENTS

New para 12.2.9.3 is introduced reading as follows:

"**12.2.9.3** If the firm is unable to demonstrate that the quality management system is implemented and maintained in compliance with the requirements of ISO 9001/GOST R ISO 9001 (current version), the Register may issue a short-term certificate for a period not exceeding 90 days."

12.3 SPECIAL REQUIREMENTS

New para 12.3.5 is introduced reading as follows:

"**12.3.5 Requirements for firms engaged in verification of cyber security of onboard computer based systems (CBS) and networks (code 22025000).**

12.3.5.1 Personnel.

As regards personnel training and qualification, the firm shall:

.1 for legal entity:

have engineers and technicians (at least 2 persons) on the staff at the main place of work in accordance with the manning table, who have higher education in the direction of training (specialty) in the field of information security and work experience of rendering services in the declared kind of activity for at least 3 years, or who have any other higher education and work experience of rendering services in the declared kind of activity for at least 3 years and were trained under professional retraining programs in the field of information security;

.2 for individual entrepreneur:

have higher education in the direction of training (specialty) in the field of information security and work experience of rendering services in the declared kind of activity for at least 3 years, or have any other higher education and work experience of rendering services

in the declared kind of activity for at least 3 years as well as additional professional education under professional retraining programs in the field of information security.

12.3.5.2 The firm shall have equipment and hardware/software required for service rendering, including means for monitoring the effectiveness of information security. Such means include vulnerability scanners for information systems that shall have at least functions enabling to perform the following tasks:

- detection of known vulnerabilities and incorrect configurations (misconfiguration);
- detection of network endpoints and scanning to identify vulnerabilities in operating systems;
- verification of password policy, identification of default passwords, blank or weak passwords;
- inventory of networks to receive detailed information on hardware/software;
- checking for uninstalled operating system updates;
- identification of open ports and insecure services running.

12.3.5.3 The firm shall have RS-agreed technical and production documentation, national and (or) international standards and procedures required for service rendering."

APPENDIX 1

NOMENCLATURE OF ITEMS OF THE REGISTER TECHNICAL SUPERVISION

New codes 05140350MK and 05140360MK are introduced reading as follows:

"

05140350MK	GNSS receiver (Beidou)	3			
05140360MK	IRNSS receiver	3			

"

Code 05410000 is renamed reading as follows:

"

05410000	Cyber safety equipment for radio and navigational equipment Equipment of 460-network				
----------	--	--	--	--	--

"

Codes 15140000 and 15141000 are deleted.

PART II. TECHNICAL DOCUMENTATION

4 TECHNICAL DOCUMENTATION ON SHIPS

Para 4.1.1 is replaced by the following text:

"4.1.1 Plan approval documentation, technical designs, ~~projects involving major conversions of ships, ship passage plans as well as the documentation stated in 3.6 and 3.7~~ are subject to review and approval by RHO or by the RS Branch Office when duly authorized by RHO."

Para 4.3 is amended as follows:

"4.3 Plan approval documentation, technical designs, as well as the documentation stated in 3.6 submitted for the Register approval shall be reviewed by the Register for compliance with the Rules of RS requirements in effect on the date of contract for construction of a ship (series of ships).

~~In the absence of the contract for construction the documentation shall be reviewed for compliance with the RS requirements in effect on one of the following dates, as applicable:~~

- ~~.1 keel laying date or the date on which the ship was at a similar stage of construction;~~
- ~~.2 the date of the applicant's request for the design review (if the terms of construction of the ship (series of ships) are not known yet).~~

~~In case of 4.3.2, and if new RS requirements came into force on the date of contract for construction of the ship (series of ships), or on the keel laying date, or on the date on which the ship was at a similar stage of construction (in the absence of the contract for construction), the documentation shall be amended in compliance with these new requirements according to 1.3.2.2 of the General Regulations for the Classification and Other Activity.~~

Applicability of the international documents specified in Table 2.5.1 of the General Regulations for the Classification and Other Activity to the above documentation is usually defined in each specific international document."

APPENDIX 1

SHIP OPERATIONAL DOCUMENTATION FOR THE ITEMS OF RS TECHNICAL SUPERVISION

Table 1. Item 12.1 is replaced by the following text:

12 – Recycling					
12.1	Inventory of Hazardous Materials (Part I)	+	+	Compliance of the Inventory to the requirements shall be endorsed by the RS surveyor's signature and stamp <u>Agreed</u>	In accordance with the Regulation (EU) No. 1257/2013 of the European Parliament, the Hong Kong International Convention for the Safe and Environmentally Sound Recycling of Ships, 2015 Guidelines for the development of the inventory of hazardous materials (refer to IMO resolution MEPC.269(68)); 3.32, Part III "Survey of Ships in Compliance with International Conventions, Codes, Resolutions and Rules for the Equipment of Sea-Going Ships" of the Guidelines on Technical Supervision of Ships in Service

12 SOFTWARE

12.3 SOFTWARE FOR STRENGTH CALCULATIONS

Para 12.3.2.4 is amended as follows:

"12.3.2.4 In case of satisfactory verifications results the Report (form 6.3.10-6.3.29) and Type Approval Certificate for Software (CTOP) (form 6.8.5) are issued."

APPENDIX 1

SHIP OPERATIONAL DOCUMENTATION FOR THE ITEMS OF RS TECHNICAL SUPERVISION

Table 1. Section 44 is replaced by the following text:

44 — Cyber resilience					
44.1	Zones and Conduit Diagram	+	-	Approved	Part XXI "Cyber Resilience" of the Rules for the Classification and Construction of Sea-Going Ships
44.2	Cyber Security Design Description	+	-	Agreed	Part XXI "Cyber Resilience" of the Rules for the Classification and Construction of Sea-Going Ships
44.3	Ship Asset Inventory	+	-	Agreed	Part XXI "Cyber Resilience" of the Rules for the Classification and Construction of Sea-Going Ships
44.4	Risk assessment for the exclusion of CBS	+	-	Approved	Part XXI "Cyber Resilience" of the Rules for the Classification and Construction of Sea-Going Ships. In the case of derogation from the application of the relevant requirements
44.5	Description of compensating countermeasures	+	-	Agreed	Part XXI "Cyber Resilience" of the Rules for the Classification and Construction of Sea-Going Ships. In the case of compensatory measures
44.6	Ship Cyber Resilience Test Procedure	+	-	Approved	Part XXI "Cyber Resilience" of the Rules for the Classification and Construction of Sea-Going Ships
44.7	Ship Cyber Security and Resilience Program	+	-	Agreed	Part XXI "Cyber Resilience" of the Rules for the Classification and Construction of Sea-Going Ships

PART III. TECHNICAL SUPERVISION DURING MANUFACTURE OF MATERIALS

6 APPROVAL OF WELDING PROCEDURES FOR STEEL STRUCTURES AND ITEMS

6.1 GENERAL

Para 6.1.1 is amended as follows:

"6.1.1 For welding of structures subject to the Register technical supervision the welding procedures defined by the relevant welding procedure specifications (WPS) which have passed qualification tests and are approved by the Register shall be used. The document confirming that the RS-approved welding procedure satisfies all the requirements established in this Section, is Welding Procedure Approval Test Certificate (COTΠC), form 7.1.33."

Para 6.1.2 is amended as follows:

"6.1.2 Unless otherwise agreed, the approval by welding procedure qualification tests shall be carried out for preliminary WPS (pWPS) and followed by filling in the established forms of welding procedure qualification records (WPQR).

Welding procedure is approved by the Register to verify that a firm carrying out welding operations is adequately qualified for their proper performance using a particular technology (welding procedure).

On agreement with the Register if form and sizes of standard welded test pieces and welded test samples given in this Section, present incorrectly a weld of production structure or product, the welding procedure approval scheme via qualification may be used based on carrying out pre-production welding tests meeting the requirements of ISO 15613, as well as In addition on agreement with the Register, approval scheme may be used based on adoption of a standard WPS in compliance with the requirements of the latest version of ISO 15612."

Para 6.1.3 is amended as follows:

"6.1.3 Approval of welding procedures shall meet the requirements set forth below. One may be guided by the ~~RS-recognized~~ applicable requirements of ~~RS-recognized~~ international and national standards ISO 15614-1, ASME Section IX, ANSI/AWS D1.1 taking into account the requirements for the extent of tests and range of approval given below if relevant requirements are not available in this Section."

Para 6.1.5 is amended as follows:

"6.1.5 In some cases the Register may require additional welding procedure testing during production. This type of testing is resorted to when there are some doubts about stability of the product quality, or some changes in the procedure parameters, or when the standard or ~~preliminary~~ (pre-production) tests are insufficient, in the Register opinion, for a particular welding procedure. Such welding procedures with higher probability of deviations in quality of welded joints include:

vertical downward welding;

one-side (single side) welding without backing (with free back-formation) of the weld by coated electrodes or flux cored wire;

friction stir welding;

welding processes with high level of heat input (electro gas arc welding, electro slag welding, etc.);

welding processes highly susceptible to the quality of parts assembling and edge preparation, e.g. electron beam and laser welding."

New para 6.1.6 is introduced reading as follows:

"6.1.6 In case of approval of welding procedures for structures of cargo tanks, process pressure vessels, cargo and production pipelines and secondary barriers of ship for carriage of liquefied gases in bulk and for ships equipped for use of gas or fuel with low flashpoint as a fuel, one shall be guided by relevant requirements for performance of tests given in Section 3, Part IX "Materials and Welding" of the Rules for the Classification and Construction of Ships Carrying Liquefied Gases in Bulk considering applicable requirements of this Section."

6.2 DEFINITIONS, TERMS AND SYMBOLS

Para 6.2.1 is amended as follows:

"6.2.1 Definitions, explanations and terms.

For the purpose of this Section the following definitions have been adopted.

Production tests mean the tests, including destructive tests, which are based on welding of specimens obtained directly in the course of product manufacture and subjected to the same treatment, as the actual products. Besides, depending on particular conditions and possibilities, the specimens may be cut out of extra lengths (allowances) of structures or be manufactured in conditions identical with those of product manufacture and using the same WPS.

Essential variables for welding procedure mean welding procedure parameters which define scope of welding procedure approval by the Register based on the welding procedure qualification tests and stated in the WPS.

Welding procedure qualification record (WPQR) means the documents in the established by the Register form or based on the acceptable standards containing complete information on testing for approval of welding procedure. WPQR includes the following forms (records) Details of Weld Test and Test Results.

Heat input E_1 means electric energy consumed per unit weld length and calculated by the formula $E_1 = IU/v$, kJ/cm, where I means welding current, A; U means welding voltage, B; v means welding speed, cm/s.

Pre-production welding tests mean the tests for approval of welding procedure based on the use of non-standard specimens and test pieces and simulating welding in actual production conditions.

Preliminary welding procedure specification (pWPS) means WPS based on the previous welding experience and recommendations of welding consumables and base metal manufacturers, but having no confirmation and approval. Welding of specimens for approval of welding procedure is carried out in accordance with the pWPS.

Welding procedure qualification tests mean the tests conducted under technical supervision and within the scope of the RS requirements to confirm the capability of the manufacturer to carry out welding of particular structures; the tests closely simulate actual working conditions and are performed in accordance with the WPS requirements.

Welding Procedure Approval Test Certificate means the RS document certifying that the welding procedure applied at the shipyard or firm (manufacturer of welded structures) has passed the tests and is approved by the Register for application.

Welding procedure specification (WPS) means a document compiled by the manufacturer of welded structures and containing all the necessary information on welding of a particular joint, including specifications for materials, welding method, edge preparation data and all process parameters.

Standard welding procedure means the welding procedure that has passed all the qualification tests provided by the requirements of this Section and WPS was approved by

the Register for use at the specific manufacturer of welded structures. The term standard welding procedure" there with is applied to the welding procedure approved by the "Register if the last is used at other workshops of the manufacturers of welded structures, which shall be totally identical to those in the WPS approved by the Register (without test performance or with tests of much-reduced scope) taking into account the requirements of 6.6.1.3.".

Para 6.2.2.3 is amended as follows:

"6.2.2.3 When executing the documentation related to the approval of welding processes, ~~it is recommended to use coding of welded joint~~ the following types of welding techniques of welded joints shall be used as follows:

- A — single-sided butt weld with backing;
- B — single-sided butt weld without backing;
- C — double-sided butt weld with back gouging;
- D — double-sided butt weld without back gouging;
- TW — T-joint weld with edge preparation (with full or partial penetration);
- F — fillet weld without edge preparation;
- ss — single-side welding (for fillet and T-joint welds);
- bs — welding from both sides (for fillet and T-joint welds);
- sl — single-layer run weld;
- ml — multilayer -run welding;
- ~~nb — welding without backing;~~
- ~~mb — welding with backing;~~
- gb — welding with gas backing;
- ~~gg — welding with back gouging or back grinding of welds;~~
- ~~ng — welding without back gouging."~~

Para 6.2.2.5 is amended as follows:

"6.2.2.5 Symbols of components of gas and gas mixtures used in welding (welding processes 131, ~~132~~, 133, 135, 136, 138, 141 and 15) shall meet the requirements of ISO 14175:2008 and are given in Table 6.2.2.5."

6.3 TYPES OF WELDED JOINTS TEST PIECES AND REQUIREMENTS FOR THEIR PREPARATION

Para 6.3.1.1.2 is amended as follows:

"6.3.1.1.2 Length or number of test pieces shall be sufficient to allow all required qualification tests to be carried out in compliance with the requirements stated bellow. Additional test pieces, or longer test pieces than the minimum size, may be prepared in order to allow for extra and/or for re-testing specimens in compliance with the requirements of the present Section.

~~The number of the Tekken test pieces for cold cracking tests shall be as follows:~~

~~at least one test piece for gas-shielded automatic welding and self-shielded tubular-cored arc welding (without additional gas shielding);~~

~~at least two test pieces for manual metal arc welding with covered electrode, partly mechanized gas-shielded welding and self-shielded tubular-cored arc welding (without additional gas shielding)."~~

Para 6.3.1.2 is amended as follows:

"6.3.1.2 The test piece for a butt-welded joint in plates shall be prepared in accordance with Fig. 6.3.1.2.

Notes: 1. When testing automatic single-side welding procedures at specialized assembling and welding stands provided with clamping devices, the test piece length shall not be less than 3000 mm.

2. When testing automatic vertical welding procedures, including forced weld formation, the test piece length shall correspond to technical capabilities of the equipment applied in production.

Strips for butt-welded test pieces from rolled plates shall be prepared taking into account the last rolling direction and axial orientation of specimens for impact test, the test results for which are given in accompanying documents for the base metal (refer also to Table 6.4.4.7.4). For impact tests of rolled products with the use of longitudinal specimens, KV_L (as a rule, for all hull structural steels of normal and higher strength) the test pieces are welded in such a way, that the weld is perpendicular to the direction of last rolling. In impact tests of rolled products using transverse specimens, KV_T the weld shall be parallel to the direction of last rolling (as a rule, for high-strength steels and steels of improved weldability).

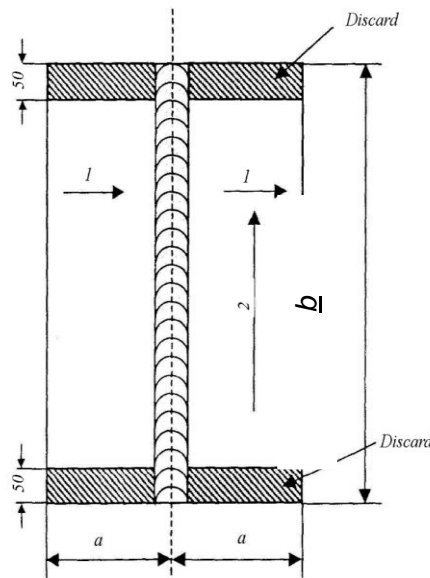

Fig. 6.3.1.2

Test piece for a butt-welded joint in plates:

1 — rolling direction for plates impact tested in the longitudinal direction KV_L (longitudinal specimens);

2 — rolling direction for plates impact tested in the transverse direction KV_T (transverse specimens);

a and b — test piece dimensions adopted depending on a welding process:

$a \geq 150$ mm, but not less than $3t$ and $b \geq 350$ mm,

but not less than $6t$ for manual and semi-automatic welding;

$a \geq 200$ mm and $b \geq 1000$ mm for automatic welding; t — thickness of the test piece".

Para 6.3.1.4 is amended as follows:

"6.3.1.4 Welding procedures for corner, tee (T-), lap and cruciform joints fillet-welded in plate are approved on the basis of testing the T-joint test piece, which is prepared in accordance with Fig. 6.3.1.4.

Note. In case of approval of automatic welding procedures for framing at specialized assembling and welding stands provided with clamping devices and ensuring fillet welding from both sides simultaneously, the test length shall be not less than 3000 mm.

Use of T-joint test piece in plate without edge preparation is limited by the following conditions and requirements:

applied welding consumables are of special purpose type and not used for welding butt joints in production;

the given procedure prevails in production and its approval within the range of approval for butt joints is inexpedient to perform;

approval cannot be performed within limitations for the range of approval;

for approval of welding procedures for fillet welds with deep penetration (rated thickness of the fillet weld exceeds the nominal one);

upon the Register requirement for the approval of welding procedures for single-run fillet welds without removal of the shop primer.

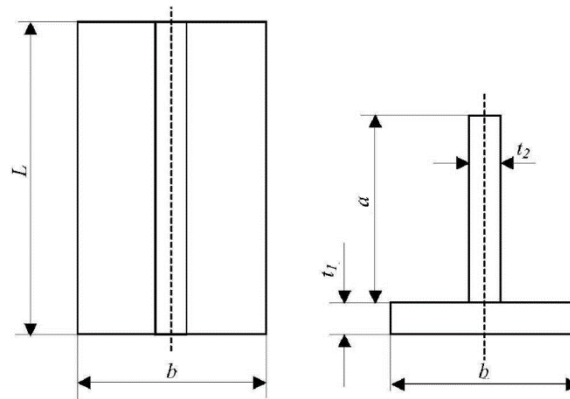

Fig. 6.3.1.4

Test piece for a fillet-welded T-joint without edge preparation:
web depth $a \geq 3t_2$, minimum value 150 mm; flange width $b \geq 3t_1$, minimum value 150 mm;
 t_1 — flange thickness; t_2 — web thickness;
test piece length $L \geq 350$ mm, but no less than $6 \max\{t_1 \text{ and } t_2\}$
for manual and semi-automatic welding and $L \geq 1000$ mm for automatic welding".

Para 6.3.1.5 is amended as follows:

"6.3.1.5 Welding procedures for corner, T- and cruciform joints in plate with full penetration are approved on the basis of testing of butt weld test piece with full penetration in accordance with Fig. 6.3.1.2, or the T-joint test piece, which is prepared in accordance with Fig. 6.3.1.5 provided that this procedure prevails in production and its approval within the range of approval for butt joints is inexpedient to perform.

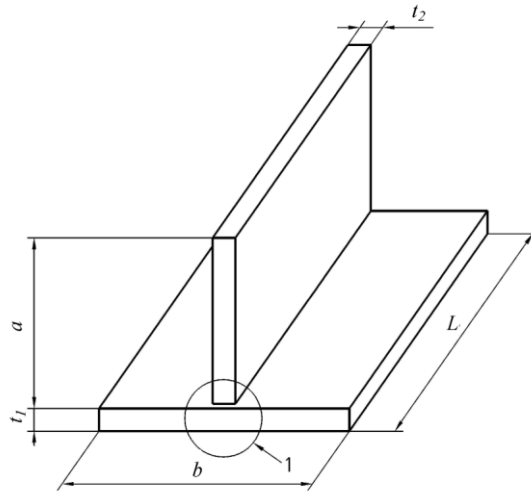

Fig. 6.3.1.5

The test piece of a T-joint in plate with full penetration:
web depth $a \geq 3t_2$, minimum value 150 mm; flange width $b \geq 3t_1$, minimum value 150 mm;
 t_1 — flange thickness; t_2 — web thickness;
test piece length $L \geq 350$ mm, but no less than $6 \max\{t_1 \text{ and } t_2\}$ for manual and semi-automatic welding
and $L \geq 1000$ mm for automatic welding; 1 — edge preparation and fit-up as detailed in the pWPS".

Para 6.3.1.6 is amended as follows:

"6.3.1.6 Welding procedures for pipe and branch connections are approved on the basis of testing the test piece for a branch connection which is prepared in accordance with Fig. 6.3.1.6 if in production the welding of branch connections is performed with an angle $\alpha_1 < 60^\circ$ between axes.

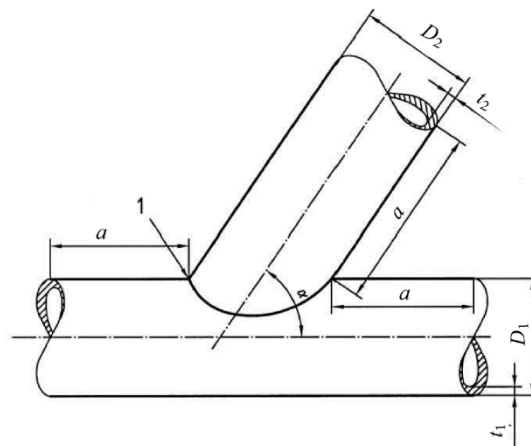

Fig. 6.3.1.6

Test piece for a branch connection:
 $a \geq 150$ mm; D_1 — outside diameter of the main pipe; t_1 — wall thickness of the main pipe;
 D_2 — outside diameter of the branch pipe; t_2 — wall thickness of the branch pipe; α — branch angle that shall be equal to minimum value of angle applied in production;
1 — edge preparation and fit-up as detailed in the pWPS".

Para 6.3.1.7 is amended as follows:

"6.3.1.7 Welding procedures for high strength steels are approved considering testing results of the Tekken test pieces prepared in accordance with Fig. 6.3.1.7 from base and welding materials for cold cracking according to GOST R ISO 17642-2-2012.

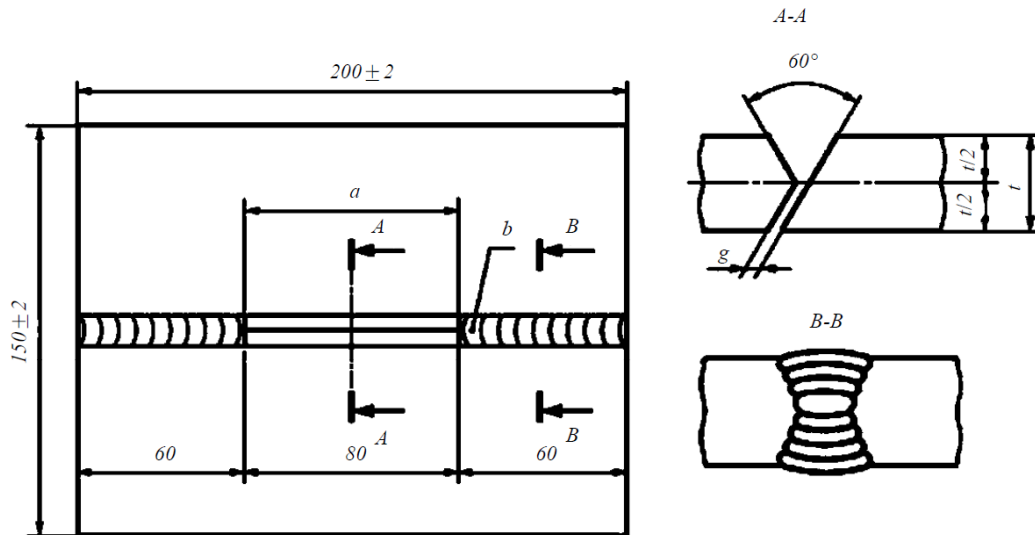

Fig. 6.3.1.7

The Tekken test piece after anchor welding:

a — tested weld deposition zone; b — anchor weld; g — root gap of $(2,0 \pm 0,2)$ mm;
 t — plate thickness taken as the largest of the declared thicknesses for a given steel grade, but not less than 12 mm.

The number of the Tekken test pieces for cold cracking tests shall be as follows:
at least one test piece for gas-shielded automatic welding and self-shielded tubular-cored arc welding (without additional gas shielding);
at least two test pieces for manual metal arc welding with covered electrode, partly mechanized gas-shielded welding and self-shielded tubular-cored arc welding (without additional gas shielding)."

Para 6.3.2.1.3 is amended as follows:

"6.3.2.1.3 For butt joint test pieces in plates it is allowed to overlap positions of PA (flat) and PE (overhead) welding of a single test piece as of actual structure and preferably relates to welds performed in mounting conditions. To weld butt welds of structures in PA position with edges (on both sides), an individual test piece shall be welded in the same way for approval of welding procedure."

Para 6.3.2.2.5 is amended as follows:

"6.3.2.2.5 Welding of test pieces shall be performed, ~~as far as possible, with the use of production equipment and in workshop conditions~~ in conditions similar to production ones in respect to welding equipment, edge preparation depending on the welding position by preheating, post-weld heat treatment, etc."

6.4 REQUIREMENTS FOR TEST PIECES EXAMINATION, TEST SPECIMENS PREPARATION AND TEST RESULTS EVALUATION

Table 6.4.1.1 is amended as follows:

"Table 6.4.1.1

Requirements for extent of testing for approval of welding procedures

Nos.	Type of welded test piece	Type of test	Extent of testing
1	Butt joint in plate and pipe — refer to Figs. 6.3.1.2 and 6.3.1.3	Visual and measurement testing	100 % of weld length
		Radiographic or ultrasonic testing ^{1,2}	100 % of weld length
		Surface crack detection ²³	100 % of weld length
		Transverse tensile test	2 specimens
		Transverse bend test ²⁴	4 specimens
		Impact test	From 3 to 8 series of 3 specimens each ⁴⁵
		Hardness test ⁵⁶	Required
		Macro examination	1 transverse macrosection
2	T-joints in plate with edge preparation (with full penetration), refer to Fig. 6.3.1.5. Pipe branching node with edge preparation on branch to be welded on (double tee-butt joint), refer to Fig. 6.3.1.6	Visual and measurement testing	100 % of weld length
		Surface crack detection ²³	100 % of weld length
		Ultrasonic testing ^{1,2}	100 % of weld length
		Hardness test ⁶	1 or 2 specimens required ⁷
		Macro examination	2 or 3 transverse specimens required ⁷
3	T-joints in plate without edge preparation (fillet/joint), refer to Fig. 6.3.1.4. Pipe branching node without edge preparation on branch to be welded (without penetration), refer to Fig. 6.3.1.6	Visual and measurement testing	100 % of weld length
		Surface crack detection ²³	100 % of weld length
		Hardness test ⁵⁶	1 or 2 specimens required ⁷
		Macro examination	2 or 3 transverse specimens required ⁷
		Fracture test	Required for the test piece of a joint in plate
4	Tekken test piece (for welding of high strength steels)	Visual and measurement testing for surface cracks	100 % of weld length
		Macro examination of the test weld for cracks	4 transverse specimens in the absence of any visible surface cracks in the weld

¹ Ultrasonic testing shall not be used at base metal thicknesses $t < 8$ mm, as well as for austenitic and austenitic stainless steels (groups 8 and 10 according to ISO/TR 15608).

⁶² For outside diameter $D \leq 50$ mm no ultrasonic test is required. For outside diameter $D > 50$ mm and where it is not technically possible to carry out ultrasonic testing, a radiographic testing shall be carried out on the maximum weld length available.

²³ Penetrant testing or magnetic particle testing. For non-magnetic materials, penetrant testing.

²⁴ In compliance with the requirements of 6.4.4.2.

⁴⁵ In compliance with the requirements of 6.4.4.4. For butt welds of pipes with outside diameter less than 102 mm and/or wall thickness less than 3.5 mm, impact tests of test pieces are not required.

⁵⁶ Hardness test is required if prescribed by requirements in 6.4.4.5.

⁷ In compliance with the location of test specimens for tests according to Figs. 6.4.2-2 to 6.4.2-5.

⁸ ~~In cases when the welding procedure according to pWPS is not subjected to approval testing by other methods, additional tests to check the mechanical properties (mechanical tests) shall be conducted on a butt joint test piece with identical edge preparation.~~

Para 6.4.1.2 is amended as follows:

6.4.1.2 Requirements for welding procedure qualification test of welding procedures of brittle crack arrest steels with indices "BCA1" and "BCA2" (BCA — brittle crack arrest steels) shall comply with the requirements for each steel grade without indices "BCA1" or "BCA2", excluding those of considering additional requirement on hardness measurements specified in 6.4.4.5.

Para 6.4.4.1 is amended as follows:

"6.4.4.1 Tensile test.

6.4.4.1.1 Tensile test of test pieces in plate.

Two transverse tensile specimens taken from the test pieces for butt joints in plate and pipe having dimensions as shown in Fig. 6.4.4.1.1-1 or 6.4.4.1.1-2 shall be tested.

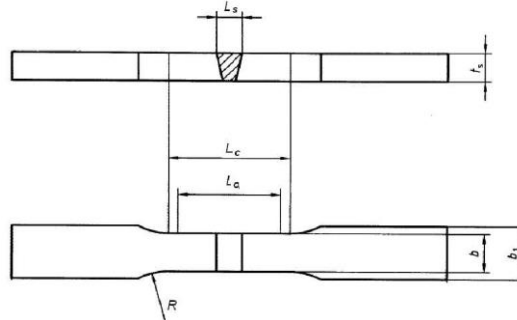

Fig. 6.4.4.1.1-1

Transverse specimen for tensile test of plates:

L_s — greatest weld width (weld top); $L_c = L_s + 60$ mm — parallel test length; L_0 — gauge length;
 b — width of the parallel test length is defined as follows: $b = 12$ mm for $t_s \leq 2$ mm and $b = 25$ mm for $t_s > 2$ mm;
 $b_1 \geq (b + 12)$ mm — width of the specimen gripping part; t_s — thickness of specimen; $R \geq 25$ mm — transition radius

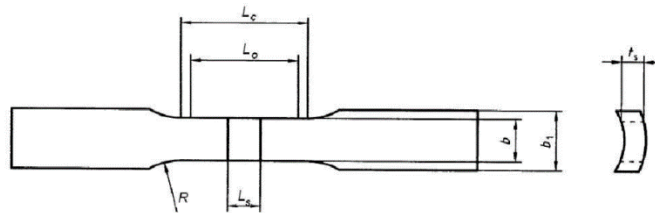

Fig. 6.4.4.1.1-2

Transverse specimen from a butt joint in pipes for tensile test:

L_s — greatest weld width (weld top);
 $L_c \geq L_s + 60$ mm — parallel test length;
 L_0 — gauge length; b — width of the parallel test length is defined as follows:
 $b = 6$ mm for $D \leq 50$ mm, $b = 12$ mm for $50 < D \leq 168,3$ mm and $b = 25$ mm for $D > 168,3$ mm;
 $b_1 \geq (b + 12)$ mm — width of the specimen gripping part;
 t_s — thickness of specimen; $R \geq 25$ mm — transition radius

Thickness of a test specimen t_s shall be, as a rule, equal to the thickness of a base metal (refer to Fig. 6.4.4.1.1-3, a). In case the testing of the weld full section is required with metal thickness above 30 mm, several specimens shall be cut out to cover the overall weld thickness (refer to Fig. 6.4.4.1.1-3, b). In this case location of each specimen shall be indicated in the test report.

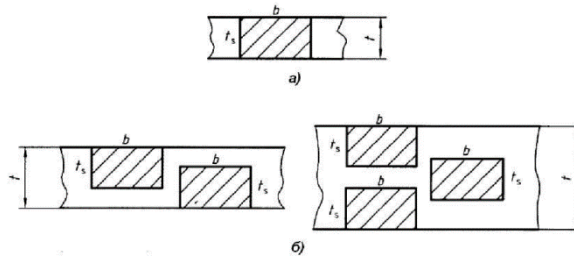

Fig. 6.4.4.1-3

Example showing the position of test specimens in welded joint section:

- a — testing of base metal full section $t_s = t$;
b — testing of several specimens in section for $t > 30$ mm

For pipes $D > 50$ mm outside diameter, the weld reinforcement shall be removed on both faces to give the test specimen a thickness equal to the wall thickness of the pipe.

For pipes $D \leq 50$ mm outside diameter, and when full section small diameter pipes are used, the weld reinforcement may be left undressed on the inside surface of the pipe.

The tensile strength value when testing transverse tensile specimens of butt-welded joints made of normal, higher and high strength hull structural steels shall not be less than the values given in Table 6.4.4.1.1. In other cases the tensile strength value determined during testing shall not be less than the values stated in Part XIII "Materials" of the RS Rules/C or in the Register agreed national/international standards for the relevant base metal taking into account its thickness.

For dissimilar butt-welded joints the minimum tensile strength value shall be specified for the material having the lowest tensile strength.

Table 6.4.4.1.1

Test result requirements for specimens of welded joints of normal, higher and high strength steel

Grade of welded steel	Consumable quality grade complying with the strength level	Tensile test, min				Bend test ¹		Hardness test HV10, max
		Transverse specimens, R_m , in MPa	Longitudinal round specimens			Mandrel diameter $r D$	Bending angle, α , in deg.	
			R_m , in MPa	R_{eH} , in MPa	A_5 , in %			
A — E	1 — 3	400	400 — 560	305	22	4t	180	Not standardized
A32 — F32	(1 — 4)Y	440 490	490 — 660	375	22	4t	180	Not standardized
A36 — F36	(2 — 4)Y	490	490 — 660	375	22	4t	180	350
A40 — F40	(2 — 5)Y40	510	510 — 690	400	22	4t	180	350
A420 — F420(W)	(3 — 5)Y42	530 520	530 520 — 680	420	20	5t	180	350
A460 — F460(W)	(3 — 5)Y46	570 540	570 540 — 720	460	20	5t	180	420
EH47	4Y46	570	570 — 720	460	19	5t	180	350
A500 — F500(W)	(3 — 5)Y50	610 590	610 590 — 770	500	18	5t	180	420
A550 — F550	(3 — 5)Y55	670 640	670 — 830 640 — 820	550	18	6t	180	420
A620 — F620	(3 — 5)Y62	720 700	720 700 — 890	620	18	6t	180	420
A690 — F690	(3 — 5)Y69	770	770 — 940	690	17	6t	180	420
A890 — E890	(3 — 5)Y89	940	940 — 1100	890	15	7t	180	450
A960 — E960	(3 — 5)Y96	980	980 — 1150	960	15	8t	180	450

¹ t is the thickness of a bend test specimen.

6.4.4.1.2 Tensile test of longitudinal round tensile test specimens.

If for welding of test pieces the welding consumables were used, which have no Certificate of Approval for Welding Consumables, one or two (depending on the welding process) longitudinal round tensile test specimens with 10 mm diameter of effective part shall be

additionally prepared and tested in accordance with Fig. 6.4.4.1.2-41. The following version of specimen's preparation for testing is acceptable:

cutting from the butt-joint test piece, if the dimensions of the specimen effective part are fit for weld cross-section in accordance with Fig. 6.4.4.1.2-52;

cutting from additionally prepared deposited metal test piece meeting the requirements of 5.4.2 for relevant welding consumables and welding processes.

Note. When the specimens are taken from the butt-welded joint test piece, proportional round tensile test specimens with 6 mm diameter of effective part may be used, if the effective part of 10 mm diameter does not fit the weld cross-section.

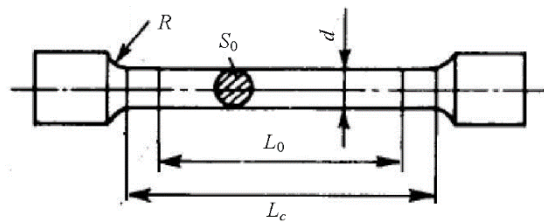

Fig. 6.4.4.1.2-41

Longitudinal round specimen for weld metal tensile tests:

$d = 10\text{ mm}$ — diameter of the parallel test length; $L_0 = 5d$ — gauge length; $L_c = L_0 + d$ — parallel test length; $R = 10\text{ mm}$ — transition radius

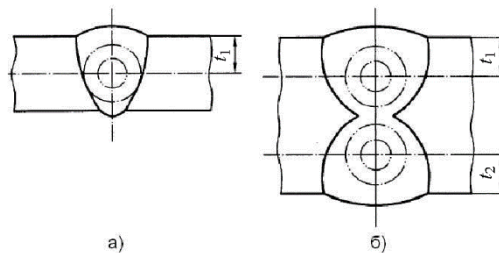

Fig. 6.4.4.1.2-2

Location of longitudinal round test specimens for tensile tests: a — test specimen from a joint welded from one side only; b — test specimen from a joint welded from both sides

When longitudinal round specimens are tested, the values of mechanical properties of the weld metal shall meet the requirements of Part XIV "Welding" of the RS Rules/C for the relevant grades of welding consumables, and also shall correspond to the values given in Table 6.4.4.4.1 and that shall not be less than the minimum required for the approval of the appropriate grade of consumable.

Where more than one welding process or type of consumable has been used to make the test weld, test specimens shall be taken from the areas (layers) of the weld where each was used with the exception of those welding procedures or consumables used to make the first weld run or root deposit."

Para 6.4.4.2 is amended as follows:

"6.4.4.2 Bend test.

Four transverse bend test specimens taken from the test pieces of butt joints in plate and pipe having dimensions as shown in Fig 6.4.4.2-1 shall be tested for static bend:

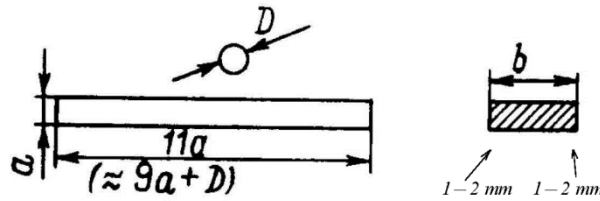

Fig. 6.4.4.2-1

Test specimens for bend test:

- a) at $t < 12$ mm
(specimens with extension of a weld root and weld face),
 $a = t$, $b = 30$ mm;
 - b) at $t \geq 20$ mm (specimens for side bend), $a = 10$ mm, $b = t$;
 - c) at $12 \leq t < 20$ mm, type a) or b) specimens may be used;
- t — thickness of the test piece

for thicknesses of a base metal $t < 12$ mm two root and two face bend test specimens shall be tested;

for thicknesses of a base metal $12 \leq t < 20$ mm four side bend specimens are recommended instead of root and face bend tests;

for thicknesses of a base metal $t \geq 20$ mm four side bend specimens shall be tested.

The upper and lower surfaces of the weld shall be filed, ground or machined flush with the surface of the plate and the sharp corners of the specimens rounded to a radius not exceeding 2 mm.

The bend test methods are shown in Fig. 6.4.4.2-2.

If the test procedure allows for the bending (wrapping) of test specimen around the mandrel, the test specimen length may exceed $11a$.

When testing specimens for side bending and if the base metal thickness $t \geq 40$ mm, the specimen may be divided into two parts of width $b \geq 20$ mm.

When testing dissimilar welded joints, the tests of transverse bend specimens are replaced, if agreed with the Register, by testing the same number of longitudinal specimens (refer to Fig. 6.4.4.2-3) having the same orientation of a tension zone (weld root and weld face).

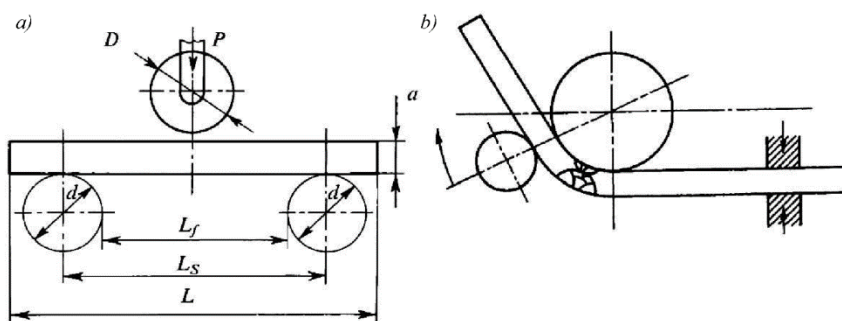

Fig. 6.4.4.2-2

Bend test methods:

a — three-point free bend test; b — wrap around bend test

Symbols: D — mandrel diameter; $L_f = D + 3a$ — free interval between rollers;

$L \approx 9a + D$ for version a) or $L \approx 11a$ for version b) — specimen length;

$L_s = L_f + d$ — free interval between supporting rollers; d — diameter of supporting rollers

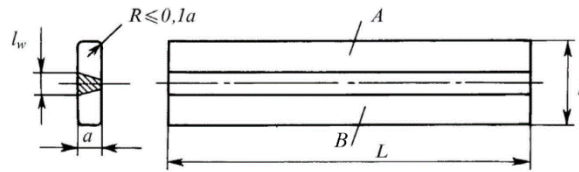

Fig. 6.4.4.2-3

Longitudinal bend test specimen for dissimilar welded joints:
A and *B* — parts of the dissimilar welded joint of steels different grades or classes;
 $L \approx 9 a + D$ for version *a*) or $L \approx 11 a$ for version *b*);
L — specimen length;
 $a = t$; $b = (l_w + 20)$ mm at $t \leq 20$ mm and $b = (l_w + 30)$ mm at $t > 20$ mm

During bend testing the mandrel diameter shall be equal to 4 specimen thicknesses ($4t$) when applying welding consumables for test specimens made of normal and higher strength steels. If for test specimens welding consumable made of high strength steels are used, the mandrel diameter shall be chosen considering relevant values from Table 6.4.4.4.

In cases not specified in Table 6.4.4.4 the following requirements shall be met: the diameter of the former or the inner roller D shall be equal to $4t$ for steels with nominal elongation $A_5 \geq 20$ %;

for the base metal with elongation $A_5 < 20$ % the following formula shall be applied:

$$D = \frac{(100 \times t)}{A_5} - t$$

where D = diameter of the former or the inner roller, in mm;

t = thickness of the bend test specimen, in mm;

A_5 = minimum tensile elongation required by material specification (nominal value), in %.

The tests shall be carried out until the bending angle of 180° is reached. After testing, the test specimens shall not reveal any open defects in any direction greater than 3 mm. Defects appearing at the corners of a test specimen during testing shall be investigated and evaluated case by case.

The longitudinal bend test results (Fig. 6.4.4.2-3) are subject to agreement with the Register in each particular case. In so doing, the above ratios relative to the material with the lower value of nominal elongation A_5 are recommended to be assumed as the basis."

Para 6.4.4.3 is supplemented by the following **new paragraph**:

"During testing of T-joint welds for static fracture, the specimen's fracture surface shall be inspected for the presence of inadmissible internal defects (pores and clustered porosity, slag inclusions, lack of fusion and cracks), the value of fusion in the root weld shall also be checked. Imperfections that are detected shall be evaluated in accordance with the last version of ISO 5817, quality level B."

Para 6.4.4.4 is replaced by the following text:

"6.4.4.4 Impact test.

Charpy V-notch impact specimens shall comply with the dimensions shown in Fig. 6.4.4.4-1. All impact tests shall be carried out on Charpy machines complying with the requirements of ISO 148 or appropriate agreed international and national standards, and having a striking energy of not less than 300 J in testing steel specimens and not less than 150 J in testing non-ferrous metal specimens. Where the test temperature is other than

ambient temperature of the test specimen at the moment of breaking the specified temperature shall be within ± 2 °C.

V-notch specimens shall be fabricated to perform impact tests. The number of series consisting of three Charpy V-notch impact specimens each, as well as location of notches on specimens of each series shall comply with Figs. 6.4.4.4-2, 6.4.4.4-3 or 6.4.4.4-4 depending on the thickness of the test piece metal, the heat input of welding or the base metal grade.

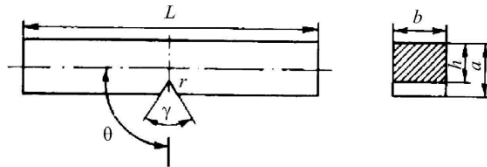

Dimensions	Nominal	Tolerances
Length L , in mm	55	$\pm 0,60$
Thickness a , in mm	10	$\pm 0,06$
Width b , in mm		
standard specimen	10	$\pm 0,11$
subsize specimen	7,5 ¹	$\pm 0,11$
subsize specimen	5,0 ¹	$\pm 0,06$
subsize specimen	2,5 ¹	$\pm 0,04$
V-notch angle γ , in deg	45	± 2
Depth below notch h , mm	8	$\pm 0,06$
Root radius r , mm	0,25	$\pm 0,025$
Distance of notch from end of test specimen $L/2$, in mm	27,5	$\pm 0,040$
Angle between plane of notch symmetry and the longitudinal axis of test specimen θ , in deg	90	± 2

¹ The required impact value on specimens of width $b < 10$ mm, $E(b)$, may be calculated based on required minimum average impact energy for specimens of width equal to 10 mm (E_{10}) according to formula (2.2.3.1) given in Part XIII "Materials" of the RS Rules/C.

Fig. 6.4.4.4-1
Charpy V-notch specimen for impact tests

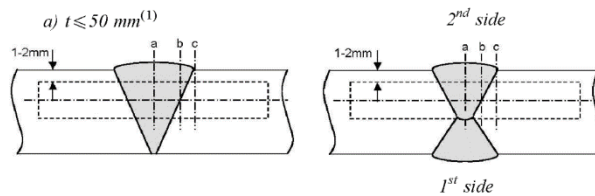

Note (1). For one side single run welding over 20 mm notch location "a" shall be added on root side.

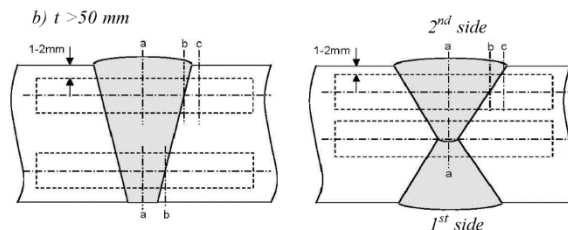

Fig. 6.4.4.4-2
Location of V-notch for butt weld of normal heat input (heat input ≤ 50 kJ/cm):
a — notch in centre of weld (WM);
b — notch on fusion line (FL);
c — notch in HAZ, 2 mm from fusion line (FL + 2)

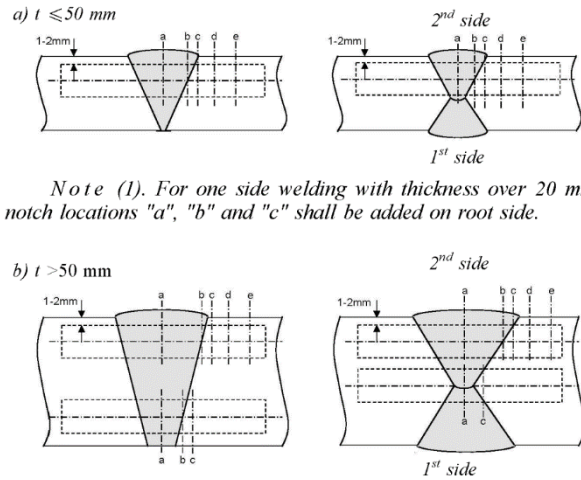

Fig. 6.4.4.4-3

Location of V-notch for butt weld of high heat input
(heat input > 50 kJ/cm):

- a — notch in centre of weld (WM);
- b — notch on fusion line (FL);
- c — notch in HAZ, 2 mm from fusion line (FL + 2);
- d — notch in HAZ, 5 mm from fusion line (FL + 5);
- e — notch in HAZ, 10 mm from fusion line (FL + 10)

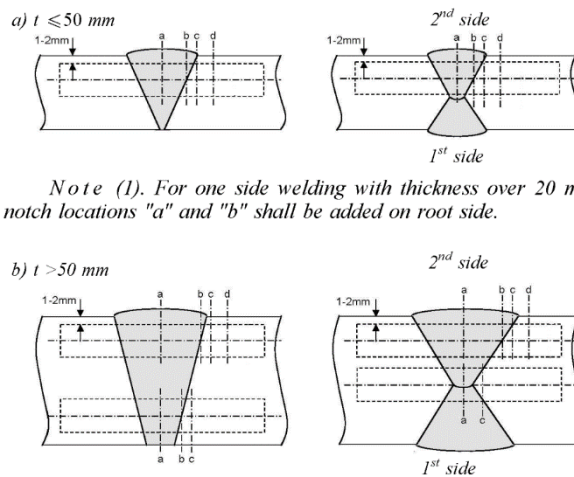

Fig. 6.4.4.4-4

Location of V-notch for butt weld of high strength steels:

- a — notch in centre of weld (WM); b — notch on fusion line (FL);
- c — notch in HAZ, 2 mm from fusion line (FL + 2);
- d — notch in HAZ, 5 mm from fusion line (FL + 5)

For welded joints of the normal, higher and high strength steels the requirements for impact test results shall comply with the requirements of Table 6.4.4.4.

Table 6.4.4.4

Impact test requirements for butt joints of normal, higher and high strength steels ($t \leq 50$ mm)¹

Grade of steel	Value of minimum average absorbed energy on weld, KV, in J				Value of minimum average absorbed energy on fusion line and in heat affected zone, KV, in J					
	Testing temperature, in C°	Electrodes and combinations for semi-automatic welding		Combinations for automatically welded joints	Testing temperature, in C°	KV _T	KV _L			
		Downhand, horizontal and overhead positions	Vertical position							
A	+20	47	34	34	+20	-	27 ^{1,2}			
B	0				0					
D	0				0					
E	-20				-20					
A32, A36	+20				+20		47 ^{1,2}			
D32, D36	0	-20	-	0	-	47 ^{1,2}				
E32, E36, E36BCA1, E36BCA2	-20									
F32, F36	-40									
A40	+20			39			39	+20	-	47 ^{1,2}
D40	0							0		
E40, E40BCA1, E40BCA2	-20	-20								
F40	-40	-40								
A420, A420W	-20	42	42		0	28		42 ³		
D420, D420W	-20			-20						
E420, E420W	-40			-40						
F420, F420W	-60			-60						
A460, A460W	-20			47	46		46		0	31
D460, D469W	-20	-20								
E460, E460W	-40	-40								
F460, F460W	-60	-60								
EH47	-20	64	64			64		-20	-	
A500, A500W	-20	50	50	50	0	33	50 ³			
D500, D500W	-20				-20					
E500, E500W	-40				-40					
F500, F500W	-60				-60					
A550	-20				55			55	55	0
D550	-20	-20								
E550	-40	-40								
F550	-60	-60								
A620	-20	62	62	62		0	41			62 ³
D620	-20				-20					
E620	-40				-40					
F620	-60				-60					
A690	-20				69	69		69	0	
D690	-20	-20								
E690	-40	-40								
F690	-60	-60								

¹ For rolled product thickness above 50 mm impact test requirements shall be specified with due regard for Table 3.2.2.-1, Table 3.2.3, Table 3.5.2.3, Part XIII "Materials" of the RS Rules/C and be subject to additional agreement with the Register.

² In accordance with 3.2.3, Part XIII "Materials" of the RS Rules/C, in general, the impact tests of delivered steel shall be performed on longitudinal (KV_L) specimens only (test results on transverse specimens shall be guaranteed by the manufacturer), unless otherwise stated by the customer and agreed by the Register.

³ In accordance with 3.13.3, Part XIII "Materials" of the RS Rules/C, unless otherwise specified by the Register, the impact tests of high strength steel plates and wide flats of more than 600 mm in width shall be performed on transverse (KV_T) specimens. Where rolled products of another cross-sectional shape are concerned, the impact tests shall be performed on longitudinal (KV_L) specimens.

For the joints between different steel grades/types, the test specimens shall be taken from the side of the joint with the lower toughness of steel. Temperature and absorbed energy results shall comply with the requirements for the lower toughness steel.

Where more than one welding process or consumable has been used to make the test weld, impact test specimens shall be taken from the respective areas where each was employed. This shall not apply to the process or consumables used solely to make the first weld run or root deposit.

The testing of sub-size specimens shall be carried out in compliance with the requirements of 2.2.3.1, Part XIII "Materials" of the RS Rules/C. In special cases, when designation of the consumables quality grade does not comply with the requirements of Table 2.2.4, Part XIV "Welding" of the RS Rules/C (e.g., for MODU and FOP structures), the absorbed energy and test temperature shall comply with the requirements of Section 4, Part XIV "Welding" of the RS Rules/C for respective consumable quality grade, relative to the weld metal and fusion line, while for the metal of heat-affected zone it shall comply with the requirements of 3.2 and 3.5, Part XIII "Materials" of the RS Rules/C for steel of respective grade considering the direction of rolled product at specimen welding. At that, for steel welded joints of grade F, the Register may require testing of the additional specimen series, having notch located on the heat-affected zone at a distance of 5 mm from the fusion line, regardless of the heat input of welding (refer to Fig. 6.4.4.4-4).

For steel castings and forgings the impact tests for the fusion line and the heat-affected zone shall be carried out in compliance with the requirements for the base metal of 3.7 and 3.8, Part XIII "Materials" of the RS Rules/C. Tests for the weld metal are conducted relative to the consumable quality grade, prescribed in the documentation approved by the Register for a particular item or structure.

For corrosion resistant steels, impact tests at approval of welding procedures shall be conducted on agreement with Register, in case this type of testing is provided for the base metal by the rules or the documentation approved by the Register for a particular product (for example, for propeller castings of corrosion resistant steels in compliance with the requirements of 3.12, Part XIII "Materials" of the RS Rules/C). Unless otherwise agreed with the Register, the temperature and estimation criteria for the impact test results shall comply with the values specified for the base metal."

Para 6.4.4.5. The last paragraph is amended as follows:

"For EH47 hull structural steel with strength level 36 and 40 and YP47 brittle crack arrest steels with indices "BCA1" and or "BCA2" in accordance with 3.2 and 3.19, Part XIII "Materials" of the RS Rules/C, measurement points shall include mid-thickness position in addition to the points specified in Figs. 6.4.4.5-1 — 6.4.4.5-6."

Para 6.4.4.5 is supplemented by the **new text**:

"The results from the hardness test shall meet the following requirements:

for higher and high strength hull structural steels the maximum values of hardness shall not exceed the values given in Table 6.4.4.1.1;

in other cases, unless otherwise specified in a contract documentation, the requirements of ISO 15614-1 given in Table 6.4.4.5 shall be met.

Table 6.4.4.5

Permitted maximum hardness values (HV 10)

Steel groups according to ISO/TR 15608	Non-heat treated	Heat treated
1 ¹	380	320
3 ²	450	380

Steel groups according to ISO/TR 15608	Non-heat treated	Heat treated
4, 5	380	320
6	–	350
9.1	350	300
9.2	450	350
9.3	450	350

¹ If hardness tests are required (refer to 6.4.4.5).
² For steels with min $R_{eH} > 960$ MPa special values shall be specified.

Para 6.4.4.6 is supplemented by the **new text**:

"Macro examination shall include regular weld profile and reveal the following:

cracks;

incomplete penetration;

lack of fusion;

inadmissible undercuts;

inadmissible internal defects (pores and slag inclusions).

The imperfections revealed shall be evaluated in compliance with the requirements of 6.4.3."

Para 6.4.4.7 is deleted.

6.6 RANGE OF APPROVAL FOR WELDING PROCEDURE BASED ON QUALIFICATION TEST RESULTS

Para 6.6.1.6 is deleted.

Para 6.6.2.1.6 is amended as follows:

"6.6.2.1.6 Approved welding procedures for hull structural steel with strength levels 36 and 40 and YP47 steel (in accordance with 3.2 and 3.19, Part XIII "Materials" of the RS Rules/C) without indices "BCA1" and "BCA2" are applicable to the same welding procedures applied to the same grade of brittle crack arrest steels with index "BCA1" or "BCA2" (BCA — brittle crack arrest steels), except high heat input processes over 50 kJ/cm."

Table 6.6.2.2 is amended as follows:

"Table 6.6.2.2

Approval range of base metal thickness t for butt and T-joint welds with edge preparation and fillet welds

Thickness of test pieces in qualification tests t , in mm ¹	Range of approval ²	
	Butt and T-joint welds with single run or single run from both sides	Butt and T-joint welds with multirun and fillet welds ³
$t \leq 3$	from t to $1,1t$ inclusive	from t to $1,5t$ inclusive
$3 < t \leq 12$	from $0,7t$ to $1,1t$ inclusive	from 3 to $2t$ inclusive
$12 < t \leq 100$	from $0,7t$ to $1,1t$ inclusive ⁴	from $0,5t$ to $2t$ inclusive (max. 150 mm)
$t > 100$	–	from $0,5t$ to $2t$ inclusive

¹ For multi processes/types of welding, the recorded thickness contribution of each process shall be used as a basis for the range of approval for the individual welding process (similar to the requirements stated in Table 4.5.2).

² During certification tests on the Tekken test piece, the range of approval is limited to 3 to $1,0t$ inclusive.

³ For fillet welds without edge preparation, the range of approval shall be applied to both base metals.

⁴ For high heat input processes over 50 kJ/cm, the upper limit of range of approval shall be up to $1,0t$ inclusive.

Para 6.6.2.2.6 is amended as follows:

"6.6.2.2.6 Notwithstanding the above, the approval of maximum thickness of base metal for any technique shall be restricted to the thickness t of test piece if three of the hardness values in the heat-affected zone are found to be within 25HV of the maximum permitted values exceeding hardness values, as stated in 6.4.4.5 for 25 units (HV)."

Para 6.6.2.2.10 is amended as follows:

"6.6.2.2.10 During approval of welding procedure related to the welding of branch connection, the range of approval for angle α_1 between axes of connected pipes shall be assigned depending on angle α at qualification tests based on ratio $\alpha \leq \alpha_1 \leq 90^\circ$ in accordance with the requirements of 6.6.3.3.3."

Para 6.6.3.2 is amended as follows:

"6.6.3.2 Welding positions.

The requirements for the range of approval according to welding positions shall meet the requirements stated in Table 6.6.3.2. The range of approval of welding procedure is limited by the welding position of test piece that has been tested. To qualify a range of positions for reduction in extent of testing, the test pieces of welded joints may be welded for highest heat input position and lowest heat input position. All applicable tests shall be made after welding on each test piece within the scope of the requirements specified in 6.4.1.1.

Table 6.6.3.2

Range of approval for welding procedures according to welding positions

Type of welding the test piece ¹	Weld position of the test piece ²	Range of approval according to welding positions ²			
		Butt welds		Fillet welds	
		Plates	Pipes	Plates	Pipes
Butt welds in plate	PA	PA	PA ³	PA	PA ³ –
	PC	PC	PC ³	PB	PA ³ , PB ³ , PD ³
	PG	PG	–PG ³	PG	–
	PF	PF	–PF ³	PF	–
	PE	PE	–PE ³	PD	PA ³ , PD ³
	PC+PF ⁴	All except for PG	All except for PG ³	All except for PG	All except for PG ³
Butt welds in pipe	PA	PA ³	PA	PA	PA
	PC	PC ³	PA, PC	PB	PA, PB, PD
	PG	PG ³	PG	PG	–
	PF	PA, PC, PE PF ³	PA, PF	PA, PB, PD PF	PA, PB, PD –
	PH	–	PH	–	PH
	PJ	–	PJ	–	PJ
	PC+PF ⁴ or H-LO45	All except for PG ³	All except for PG	All except for PG	All except for PG
Fillet welds in plate (no beveling)	PA	–	–	PA	PA ³ –
	PB			PB	PA ³ , PB ³ , PD ³
	PF			PF	–
	PG			PG	–
	PD			PD	PA ³ , PB ³ , PD ³
	PB+PD ⁴			All except for PG	All except for PG ³
Fillet welds in pipe (no beveling)	PA	–	–	PA	PA
	PB			PB	PA, PB, PD
	PG			PG	PG
	PD			PD	PA, PB, PD
	PF			All except for PG	All except for PG

¹ Branch connections are subject to separate qualification tests.

² Designations of welding positions comply with ISO 6947.

³ Pipes with outside diameter $D > 500$ mm are considered equivalent to plates according to the range of approval (not applicable to branch connections). Relevant range of approval for pipes during welding of plate test pieces and vice versa covers the application of the same process and type of welding (A, B, C, D) according to 6.2.2.3.

⁴ Welding of two test pieces in specified directions is required.

Para 6.6.3.3 is amended as follows:

"6.6.3.3 Type of welding technique and structural particulars of welded joint.

Range of approval for the types of welding technique for welded joints in accordance with to 6.2.2.3 shall be, as used in the applicable type of welding procedure qualification tests, subject to the requirements of Table 6.6.3.3 and the limitations stated below:

.1 range of approval for full penetration butt welds qualifies full and partial penetration butt welds, as well as fillet welds with (including T-joints) and without edge preparation. Qualification tests for fillet welding shall be required in cases specified by the requirements of 6.3.1.4 and testing of T-joint with edge preparation is required according to the requirements of 6.3.1.5;

.2 range of approval for butt joints in pipes may also qualify branch connections with an angle $\alpha_1 \geq 60^\circ$ according to the requirements of 6.3.1.6;

.3 range of approval for pipe and branch connection with angle between axes $\alpha_1 < 60^\circ$ shall qualify all angles of branch connection α_1 within the range of $\alpha \leq \alpha_1 \leq 90^\circ$;

-3.4 range of approval for T-joints butt welded with edge preparation (type of welding technique of T-joint (TW)) only qualifies this type of joints and fillet welds (F);

-4.5 range of approval for single-sided butt welds made from one side without backing (type of welding technique of B welds) qualifies welds with backing and welds made from both sides (for types A, B, C, D);

-5.6 range of approval for single-sided butt welds made with backing (type of welding technique of A weld) qualifies welds made from both sides (for types A and C);

.7 range of approval of double-sided butt welds with gouging of the weld root (types of welding technique for C welds) qualifies only this type of connection;

-6.8 range of approval for double-sided butt welds made from both sides without gouging of the weld root (types of welding technique for D weld) qualifies welds made from both sides with gouging (for types C and D);

-7.9 range of approval for fillet welding (F) qualifies this type of joint only;

-8.10 it is not permitted to change a multi-run deposit into a single run (or single run on each side) or vice versa for a given approval of process welding procedure.

Table 6.6.3.3

Range of approval of welding procedures by types of welding techniques of welded joints

Type of welded test assembly in tests for approval			Range of approval											
			Plates (P)								Pipes (T) ¹			
			Butt welds (BW)				T-joints (TW)				Fillet bead welds (joint) without beveling (F)	Butt welds		Fillet joints without beveling (F)
			Single-sided welding		Both Double-sided welding		Single-sided welding		Both Double-sided welding			Single-sided welding		
with backings (A)	without backings (B)	with gouging (C)	without gouging (D)	with backings (A)	without backings (B)	with gouging (C)	without gouging (D)	with backings (A)	without backings (B)					
Butt weld of plates	Single-sided welding	with backings (A)	*	–	x	–	–x	–	–x	–	x	–x	–	x
		without backings (B)	x	*	x	x	–x	–x	–x	–x	x	–x	–x	x
	Both Double-sided welding	with gouging (C)	–	–	*	–	–	–	–x	–	x	–	–	x
		without gouging (D)	–	–	x	*	–	–	–x	–x	x	–	–	x
Butt weld of pipes	Single-sided welding	with backings (A)	x	–	x	–	–x	–	–x	–	x	*	–	x
		without backings (B)	x	x	x	x	–x	–x	–x	–x	x	x	*	x
T-joint with edge preparation (TW)	Single-sided welding	with backings (A)	–	–	–	–	*	–	x	–	x	–	–	x
		without backings (B)	–	–	–	–	x	*	x	x	x	–	–	x
	Both Double-sided welding	with gouging (C)	–	–	–	–	–	–	*	–	x	–	–	x
		without gouging (D)	–	–	–	–	–	–	x	*	x	–	–	x
Fillet (gauge) weld without beveling (F)	Plates (P)		–	–	–	–	–	–	–	–	–	*	–	–
	Pipes (T)		–	–	–	–	–	–	–	–	–	x	–	–

¹ Pipes with outside diameter $D > 500$ mm shall be considered similar to the plates by ranges of approval (unacceptable to branch connections if the angle between their axes is $\alpha_1 < 60^\circ$), i.e. range of approval for welding procedure of plates qualifies welding of pipes with outside diameter $D > 500$ and vice versa.

Symbols:
 * means types of welded joints, for which WPS is approved directly by test results;
 x means types of welded joints, for which WPS may be approved by the range of approval (without additional tests);
 – means types of welded joints, for which WPS are not subject to approval.

Para 6.6.3.4.2. The first paragraph is amended as follows:

"6.6.3.4.2 Filler material designation and manufacturer.

The requirements for the range of welding procedure approval based on the designation in the appropriate national standards are applied to the filler materials and welding processes concerned and not covered by the RS approval for the grades specified by the requirements of 4.2, 4.5, 4.6 and 4.8, Part XIV "Welding" of the RS Rules/C for the Classification and Construction of Sea-Going Ships.".

Para 6.6.4.3. The first paragraph is amended as follows:

"6.6.4.3 Tungsten inert gas (TIG) welding with solid filler material (wire/rod) (welding processes 141 and 142)."

6.7 ADDITIONAL REQUIREMENTS FOR APPROVAL OF WELDING PROCEDURE FOR STRUCTURES AND ITEMS FROM SPECIAL PURPOSE STEEL

Para 6.7.5 is amended as follows:

"6.7.5 Additional requirements for approval of welding procedures of EH47 YP47 steel.

6.7.5.1 If When CTOD testing is carried out (in case if it is required by the design documentation), it shall comply with the requirements of 6.7.4.3 — 6.7.4.5 and 2.2.10.5 and 6.7.4.3 — 6.7.4.5, Part XIII "Materials" of the RS Rules/C.

6.7.5.2 Impact tests shall be carried out in accordance with 6.4.4.4 at temperature – 20 °C. Values of minimum average absorbed energy on weld KV in accordance with Table 6.4.4.7.4 shall be not less than 64 J for all welding positions.

6.7.5.3 Hardness shall be measured in accordance with 6.4.4.5. Hardness values for scale HV10 shall not exceed 350 units.

6.7.5.4 Tensile strength values during tensile test in accordance with Table 6.4.4.1.1 shall be not less than 580 MPa.".

6.8 ISSUE AND TERMS OF VALIDITY OF WELDING PROCEDURE APPROVAL TEST CERTIFICATE

Para 6.8.3.4 is amended as follows:

"6.8.3.4 Endorsement of the Welding Procedure Approval Test Certificate (COTΠC) is performed by the RS surveyor based on the request of the manufacturer of welded structures within the period stated in Section 6, Part I "General Regulations for Technical Supervision". In this case the Certificate endorsement and its reissuance for a new period do not usually require new or additional qualification tests provided all the above terms of the Certificate validity are met.

Request for endorsement of ~~the Welding Procedure Approval Test Certificate~~ COTΠC for the next ~~2,5~~two-year period shall be submitted to the Register within 30 days before and after the set date of the Certificate endorsement. ~~Validity of the Welding Procedure Approval Test Certificate may be prolonged within 90 days after the expiry of 2,5~~two-year period."

7 APPROVAL OF WELDING PROCEDURES FOR ALUMINIUM ALLOYS

7.1 GENERAL

Para 7.1.3. The second paragraph is amended as follows:

"if the peculiarities of structures welding under working conditions cannot be reproduced on type test assemblies specified by the requirements of 7.3, and the ~~qualification pre-production welding tests prior to the manufacture beginning~~ with the simulation of an actual welding procedure are needed;"

PART IV. TECHNICAL SUPERVISION DURING MANUFACTURE OF PRODUCTS

3 EQUIPMENT, ARRANGEMENTS AND OUTFIT

3.5 ANCHOR ARRANGEMENT

Para 3.5.1.1. The first paragraph is amended as follows:

"**3.5.1.1** The manufacture of forged, cast and welded SHHP anchors is subject to the Register technical supervision according to Table 3.2.4."

APPENDIX 3

TENSILE TEST OF ANCHORS AND ANCHOR SHACKLES BY PROOF LOAD

Para 3 is amended as follows:

"**3** ~~Each cast a~~ An anchor shackle shall be tested without ~~an the~~ anchor with the non-standard pin secured in it applying a proof load F_2 , in N:

$$F_2 = 2F_1$$

where F_1 = proof load for the anchor determined according to the Table and specified in the technical requirements of a drawing.

~~In some cases, this test may be carried out~~ Cast anchor shackles shall be tested by a proof load F_2 selectively in amounts of 5 % of a batch, but not less than two shackles. The batch is taken as the shackles made of one steel brand after the joint heat treatment or heat treatment as per the same conditions with the compulsory fixing of temperatures.

In proof load F_2 testing of anchor shackles (regardless of manufacturing method), no cracks and permanent set are acceptable.

~~If satisfactory results of the above mentioned tests by proof load for particular type of product~~ F_2 anchor shackles made by a method other than casting, have been received and the Recognition Certificate for Manufacturer has been issued, the following is admitted:

- .1 to conduct tests of anchor shackles by proof load together with the anchor (refer to item 24);
- .2 to conduct tensile tests of anchor shackles by proof load equal to double proof load for anchors only when endorsed by the Recognition Certificate for Manufacturer."

5 MACHINERY

APPENDIX 6

TYPE TESTING APPROVAL OF INTERNAL COMBUSTION ENGINES (ICE) AND RECOMMENDED CONTENT OF TYPE APPROVAL CERTIFICATE (CTO)

3. VALIDITY.

Para 3.3 is amended as follows:

"3.3 A type of ICE is defined by:

bore and stroke;
injection method (direct or indirect);
valve and injection operation (by cams or electronically controlled);
kind of fuel (liquid, gaseous, dual-fuel ICE);
working cycle (4-stroke, 2-stroke);
turbo-charging system (pulsating or constant pressure);
the charging air cooling system (e.g. with or without intercooler);
cylinder arrangement (in-line or V)¹;
cylinder power, speed and cylinder pressures²
gas admission method (~~direct cylinder injection after compression stroke, charge air space cylinder-individual injection before compression stroke~~ or pre-mixed) for gas engine;
gas admission supply-valve operation (mechanical or electronically controlled) for gas engine;
ignition system (pilot injection, spark ignition, glow plug or gas self-ignition) for gas engine;
ignition system (mechanical or electronically controlled).
Cylinder-individual injection before compression stroke may be port injection into the air inlet channel before the cylinder inlet valve, injection into the cylinder before or during compression stroke, or similar arrangements.

Provided documentary evidence of successful service experience with the classified rating of 100 % is submitted, an increase (if design approved³) may be permitted without a new type test if the increase from the type tested engine is within:

- 5 % of the maximum combustion pressure, or
- 5 % of the mean effective pressure, or
- 5 % of the rpm.

¹ One type test shall be considered adequate for the one-type ICE to cover a range of different numbers of cylinders. However, a type test of an in-line ICE may not always cover the V-version. Separate type tests may be required for the V-version. On the other hand, a type test of a V- engine covers the in-line engines, unless the mean effective pressure is higher.

Items such as axial crankshaft vibration, torsional vibration in camshaft drives, and crankshafts, etc. may vary considerably with the number of cylinders and may influence the choice of engine to be selected for type testing.

² The engine is type approved up to the tested ratings and pressures (100 % corresponding to MCR).

³ Only crankshaft calculation and crankshaft drawings, if modified.

Providing maximum power is not increased by more than 10 %, an increase of maximum approved power may be permitted without a new type test provided engineering analysis and evidence of successful service experience in similar field applications (even if the application is not classified) or documentation of internal testing are submitted if the increase from the type tested engine is within:

- 10 % of the maximum combustion pressure, or
- 10 % of the mean effective pressure, or
- 10 % of the rpm."

6. MEASUREMENTS AND RECORDINGS.

Para 6.2 is amended as follows:

"6.2 As a minimum, the following engine data shall be measured and recorded:
engine r.p.m;
torque;
maximum combustion pressure for each cylinder¹;
mean indicated pressure for each cylinder²;
charging air pressure and temperature;
exhaust gas temperature;
fuel rack position or similar parameter related to engine load;
turbocharger speed;
all engine parameters that are required for control and monitoring for the intended use (propulsion, auxiliary, emergency);
each fuel index for gas and diesel as applicable (or equivalent reading) for gas engines;
gas pressure and temperature at the inlet of the gas manifold for gas engines;
pilot fuel temperature and pressure (supply or common rail as appropriate) for gas engines;
gas concentration in the crankcase for gas engines.
Calibration records for the instrumentation used to collect data as listed above are to be presented to – and reviewed by the attending Surveyor.

The gas concentration in the crankcase shall normally be measured inside the crankcase or at the crankcase outlet (crankcase vent pipe). Gas concentration measurements may be carried out as part of Stage A if the method and the results are properly documented.

Additional measurements may be required in connection with the design assessment."

¹ For engines where the standard production cylinder heads are not designed for such measurements, a special cylinder head made for this purpose may be used. In such a case, the measurements may be carried out as part of Stage A and shall be properly documented. Where deemed necessary e.g. for dual fuel engines, the measurement of maximum combustion pressure and mean indicated pressure may be carried out by indirect means, provided the reliability of the method is documented.

² One type test shall be considered adequate for the one-type ICE to cover a range of different numbers of cylinders. However, a type test of an in-line ICE may not always cover the V-version. Separate type tests may be required for the V-version. On the other hand, a type test of a V- engine covers the in-line engines, unless the mean effective pressure is higher.

Items such as axial crankshaft vibration, torsional vibration in camshaft drives, and crankshafts, etc. may vary considerably with the number of cylinders and may influence the choice of engine to be selected for type testing.

7. STAGE A. INTERNAL (MANUFACTURER'S) TESTS.

Para 7.3 is amended as follows:

"7.3 Dual Fuel (DF) engines shall be tested taking in account their structural features in compliance with 7.2 in both gas and diesel modes (with and without pilot injection in service) as found applicable for the engine type.

For Dual Fuel (DF) engines with variable liquid/gas ratio, the load tests shall be carried out at different ratios between the minimum and the maximum allowable values.

For Dual Fuel (DF) engines, switch over between gas and diesel modes shall be tested at different loads.

The influence of the methane number and LHV of the fuel gas on the engine's maximum continuous power available in gas mode shall be verified."

8. STAGE B. THE TESTING MADE IN THE PRESENCE OF THE REGISTER SURVEYOR.

Para 8.4 is amended as follows:

"8.4 The load points (refer to Fig. 8.5) are:

rated power (MCR), i.e. 100 ~~per cent~~ % output at 100 ~~per cent~~ % torque and 100 ~~per cent~~ % speed corresponding to load point 1, normally for 2 hours with data collection with an interval of 1 hour. If operation of the engine at limits as defined by its specified alarm system (e.g. at alarm levels of lub oil pressure and inlet temperature) is required, the test shall be made here;

100 % power at maximum permissible speed corresponding to load point 2;

maximum permissible torque (at least and normally 110 %) at 100 % speed corresponding to load at point 3, or maximum permissible power (at least and normally 110 %) and 103,2 % speed according to the nominal propeller curve corresponding to load point 3a. Load point 3a applies to engines only driving fixed pitch propellers or water jets. Load point 3 applies to all other purposes;

part loads e.g. 75 ~~per cent~~ %, 50 ~~per cent~~ % and 25 ~~per cent~~ % of rated power and speed according to nominal propeller curve (i.e. 90,8 ~~per cent~~ %, 79,3 ~~per cent~~ % and 62,9 ~~per cent~~ % speed) corresponding to points 6, 7 and 8 or at constant rated speed setting corresponding to points 9, 10 and 11, depending on the intended application of the engine;

crosshead engines not restricted for use with C.P. propellers shall be tested with no load at the associated maximum permissible engine speed.

Dual Fuel (DF) engines shall be tested in both gas and diesel modes that apply for the engine type as defined by the engine designer (~~refer to 5.6~~). ~~This also applies to the~~ The independent overspeed protection device shall be tested both in gas and diesel mode (refer to 8.2);

~~in case of Dual Fuel (DF)~~ For engines with variable liquid / gas ratio, the load tests shall be carried out at different ratios between the minimum and the maximum allowable values (most relevant and critical loads and ratios shall be selected for the test).

The maximum continuous power available in gas mode shall be demonstrated.

Overload testing is not required in gas mode for DF engines, provided that changeover to oil fuel mode is automatically performed in case of overload.

The load tests shall be carried out in diesel mode and in gas mode at the different percentages of the engine's MCR."

Paras 8.7 and 8.8 are amended as follows:

"8.7 Functional tests:

verification of the lowest specified propulsion engine speed according to the nominal propeller curve as specified by the engine designer (even though it works on a water-brake);
starting tests, for non-reversible engines and/or starting and reversing tests, for reversible engines, for the purpose of determining the minimum air pressure and the consumption for a start;

for Dual Fuel (DF) engines, the lowest specified speed shall be verified in diesel mode and gas mode;

for ~~Dual Fuel (DF)~~ engines, switch over between gas and diesel modes shall be tested at different loads;

for DF engines, verification of automatic changeover to diesel mode when the load demand exceeds the maximum continuous power available in gas mode;

the efficiency of the ventilation arrangement or other approved principal of the double walled gas piping system shall be verified;

~~simulation of a gas leakage in way of a cylinder gas supply valve;~~

governor tests (refer to 2.11, Part IX "Machinery" of the Rules for the Classification and Construction of Sea-Going Ships) be carried out.

Thus, Gas engines driving generators shall be additionally tested in compliance with 2.11.3.2, Part IX "Machinery" of the Rules for the Classification and Construction of Sea Going Ships considering the requirements of 2.11.3.5 — 2.11.3.6, Part IX "Machinery" of the Rules for the Classification and Construction of Sea-Going Ships, and that for ~~Dual Fuel (DF)~~ engines when being tested, the transition from gas to liquid is permissible. For Gas Fuel (GF) engines, the influences of Lower Heating Value (LHV), methane number and ambient conditions on the dynamic load response test results shall be theoretically determined and specified in the test report. Referring to the limitations as specified in 9.12.1.2, Part IX "Machinery" of the Rules for the Classification and Construction of Sea-Going Ships, the margin for satisfying dynamic load response shall be determined.

8.8 Integration test.

For electronically controlled diesel engines, integration tests shall verify that the response of the complete mechanical, hydraulic and electronic system shall be as predicted for all intended operational modes. The scope of these tests shall be agreed with the Register for selected cases based on the FMEA required in 1.2.3.1, Part IX "Machinery" of the Rules for the Classification and Construction of Sea-Going Ships.

Thus, for gas engines the tests shall at least include the following incidents:

failure of ignition (spark ignition or pilot injection systems), both for one cylinder unit and common system failure;

failure of a ~~cylinder gas supply~~ admission valve;

failure of the combustion (to be detected by e.g. misfiring, knocking, exhaust temperature deviation, etc.);

abnormal gas pressure;

abnormal gas temperature (this test may be carried out using a simulation signal of the temperature)."

**9. STAGE C. SURVEY OF THE ICE COMPONENTS
WITHIN THE SCOPE REQUIRED BY THE REGISTER.**

Para 9.3 is amended as follows:

"9.3 For all the other engines, after the test run the components of one cylinder for in-line ICE and two cylinders for V-engines shall be presented for inspection as follows (ICE with long service experience from non-marine fields can have a reduced extent of opening):

piston removed and dismantled;
crosshead bearing dismantled;
guide planes;
connecting rod bearings (big and small end) dismantled (special attention to serrations and fretting on contact surfaces with the bearing backsides);
main bearing dismantled;
cylinder liner in the installed condition;
cylinder head, valves disassembled;
cam drive gear or chain, camshaft and crankcase with opened covers. (The engine shall be turnable by turning gear for this inspection);
gas ~~supply~~ admission valve including pre-chamber as found applicable;
pilot fuel injection valve (for DF engines);
spark igniter (for GF engines).".

Section 10 is amended as follows:

**"10. THE RECOMMENDED DATA TO BE SPECIFIED
IN TYPE APPROVAL CERTIFICATE (CTO) FOR ICE.**

The data and information shown in Table 10 below is recommended to be indicated in TYPE APPROVAL CERTIFICATE (CTO) for ICE. In addition the Section "~~ICE data~~ Данные по ДВС /-Engine Particulars" shall not indicate the data attributed to confidential information by the manufacturer, for example, the maximum combustion pressure. In this case the appropriate note shall be made in CTO not specified at a manufacturer's request", but such confidential information shall be given in the documents submitted to the Register review for type approval.

For DF engines, the maximum continuous power available in gas mode shall be specified on the CTO in addition to the maximum continuous rating in diesel mode if differing.".

**BENCH TESTS (FACTORY ACCEPTANCE TESTS (FAT))
AND ICE TESTS AFTER INSTALLATION ONBOARD**

3. BENCH TESTS.

Para 3.2.2 is amended as follows:

"3.2.2 For each required load point, the following parameters are normally to be recorded:
power and speed;
fuel index (or equivalent reading);
maximum combustion pressures (only when the cylinder heads installed are designed for such measurement);
exhaust gas temperature before turbine and from each cylinder (to the extent that monitoring is required in Appendix 9 and Chapter 4.2, Part XV "Automatization" of the Rules for Classification and Construction of Sea-Going Ships);
charge air temperature;
charge air pressure;
turbocharger speed (to the extent that monitoring is required in Appendix 9);
fuel index, both gas and diesel as applicable (or equivalent reading);
gas pressure and temperature-;
pilot fuel temperature and pressure (supply or common rail as appropriate).".

Para 3.3.1 is amended to read as follows:

"3.3.1 Test loads for various engine applications are given below. In addition, the scope of the trials may be expanded depending on the engine application, service experience, or other relevant reasons.

DF engines shall be tested in both diesel and gas mode as found applicable. Thus, for DF engines, the load tests referred to in 3.3.2 — 3.3.6 shall be carried out in diesel mode and in gas mode at the different percentages of the engine's MCR. ~~Maximum~~ Maximum continuous power available in gas mode shall be demonstrated (refer to 9.12, Part IX "Machinery" of the Rules for the Classification and Construction of Sea-Going Ships).

The 110 % load test is not required in the gas mode.

Note. Alternatives to the detailed tests may be agreed between the manufacturer and the Register when the overall scope of tests is found to be equivalent the requirements of 3.3."

Para 3.5 is amended as follows:

"3.5 Integration tests.

For electronically controlled engines, integration tests shall be made to verify that the response of the complete mechanical, hydraulic and electronic system is as predicted for all intended operational modes and the tests considered as a system shall be carried out at the works. If such tests are technically unfeasible at the works, however, these tests may be conducted during sea trial. The scope of these tests shall be agreed with the Register for selected cases based on the FMEA required in 1.2.3.1. Part IX "Machinery" of the Rules for the Classification and Construction of Sea-Going Ships.

Thus, for gas engines the tests shall at least include the following incidents (the failures shall be checked using simulation or other alternative methods agreed with the Register):
failure of ignition (spark ignition or pilot injection systems), for one cylinder unit;
failure of a ~~cylinder gas supply~~ admission valve;
failure of the combustion (to be detected by e.g. misfiring, knocking, exhaust temperature deviation, etc.);
abnormal gas pressure;
abnormal gas temperature."

4. PROCEDURE FOR ICE TESTS AFTER INSTALLATION ONBOARD

New Para 4.6 is introduced reading as follows:

"4.6 ICE fuelled by natural gas.

4.6.1 A leak test shall be carried out for the gas piping system (refer to 16.7.3.3 of the IGF Code) after assembly on board.

4.6.2 The maximum continuous power available in gas mode shall be demonstrated. If a test load is performed in all applicable operation modes without interruption (direct changeover at same power and speed), the duration may be considered as the total duration demonstrated in all fuel modes. However, demonstration at each mode shall not be less than one hour.

4.6.3 The starting maneuvers required in 4.2 shall be carried out in diesel mode and gas mode, if applicable.

4.6.4 For DF engines, automatic switching over to oil fuel mode shall be tested. Further, manual change over from diesel to gas mode and vice versa shall be tested.

4.6.5 The efficiency of the ventilation arrangement, or other approved principle, of the double walled gas piping system shall be verified."

APPENDIX 8

PROCEDURE FOR SURVEY AND ISSUE OF DOCUMENTS OF ICE COMPONENTS

2. ICE COMPONENTS TO BE DOCUMENTED.

Paras 2.2 and 2.3 are amended as follows:

"2.2 Symbols used are listed in Table 2.2.1. A summary of the required documentation for the ICE components is listed in Table 2.2.2 and Table 2.2.3 (applicable only for the purpose of the present Appendix).

2.3 For components and materials not specified in Table 2.2.2 or Table 2.2.3, the review shall be given by the Register upon full details being submitted."

New Table 2.2.3 is introduced reading as follows:

"Table 2.2.3

Summary of required documentation for ICE (fuelled by natural gas) components

No.	Part	Material properties	Non-destructive examination	Pressure testing	Visual inspection by surveyor	Component certificate
1	Gas pipe Low-pressure double walled	W (C+M)	W ^{1, 2}	W ³	×	
2	Single walled Gas pipes	W (C+M)	W ⁴	W ³	×	RC
3	High-pressure gas pipes	W (C+M)	W ⁴	W ³	×	RC
4	Secondary enclosure for gas pipes	W (C+M)	W ²	W ⁵	×	
5	Gas pipe Low-pressure, Flanges ⁶	W (C+M)	W ^{1, 2}		×	
6	Gas pipe High-pressure, Flanges ⁶	W (C+M)	W ⁴		×	RC
7	Gas pipe Low-pressure, Fittings and other components	W (C+M)		W ³	×	
8	Gas pipe High-pressure, Fittings and other components	W (C+M)		W ³	×	RC
9	Gas pipe Low-pressure Bodies of valves ⁷	W (C+M)		W ³		
10	Gas pipe High-pressure Bodies of valves	W (C+M)		W ³		RC
11	Gas venting pipes and flanges ⁶ , build up pressure less than 5.0 bar	TR(C+M)	W ²	W ³	×	
12	Gas venting pipes and flanges ⁶ , build up pressure at 5.0 bar or more with secondary enclosure	TR(C+M)	W ²	W ³	×	
13	Gas venting pipes and flanges ⁶ , build up pressure at 5.0 bar or more	W (C+M)	W ⁴	W ³	×	RC

No.	Part	Material properties	Non-destructive examination	Pressure testing	Visual inspection by surveyor	Component certificate
14	Gas venting pipes Secondary enclosure			W ⁸	×	
¹ If inside diameter > 75 mm or wall thickness > 10 mm: 100 % radiographic or ultrasonic inspection of all butt-welded joints (refer to 16.6.3.1 of the IGF Code). ² 10 % radiographic or ultrasonic inspection of butt-welded joints (refer to 16.6.3.4 of the IGF Code). ³ Pressure test at 1.5 x design pressure. ⁴ Gas pipe Low-pressure double walled 100 % radiographic or ultrasonic inspection of all butt-welded joints (refer to 16.6.3.1 of the IGF Code). ⁵ Pressure test at 1.5 x design pressure to ensure gas tight integrity, not less than the expected maximum pressure at gas pipe rupture (refer to 16.7.3.4, and 9.8.4 of the IGF Code). ⁶ "Flanges" limited to the final connection to the engine. ⁷ If nominal diameter > 25 mm ⁸ Leak test.						

8 SYSTEMS AND PIPING

8.5 MECHANICAL, FLEXIBLE JOINTS AND EXPANSION PIECES

Table 8.5.4.4 is amended as follows:

"Table 8.5.4.4

Test types	Joint types			References and notes
	Compression, screwed nipple and nipple unions	Sleeve		
		Fixed	Slip	
Tightness test	+	+	+	<u>8.5.4.8.1</u>
Vibration (fatigue) test	+	+	-	<u>8.5.4.8.2</u>
Pressure pulsation test ²	+	+	-	<u>8.5.4.8.5</u>
Burst pressure test	+	+	+	<u>8.5.4.8.6</u>
Pull-out test	+	+	-	<u>8.5.4.8.7</u>
Fire endurance test	+ ³	+	+	<u>8.5.4.8.8</u> (refer to 2.4.5.6*)
Vacuum test	+ ³	+	+	<u>8.5.4.8.9</u>
Repeated assembly test	+ ⁴	+	-	<u>8.5.4.8.10</u>
Symbols : + test is required; - test is not required; * of Part VIII, the Rules for Classification and Construction of Sea-Going Ship ¹ fixed that include grip type & machine grooved type ² for use in <u>all Class I and II systems and those Class III systems</u> where pressure pulsation other than water hammer is expected. ³ except joints with metal-to-metal tightening surfaces. ⁴ except <u>permanent joint type (e.g., press type and swage type)</u> .				

10 ELECTRICAL EQUIPMENT

10.1 GENERAL

New para 10.1.4 is introduced reading as follows:

"**10.1.4** For the on-board computer based systems (CBS) with RS Nomenclature codes 11100000 — 11120000, in addition to the provisions of this Section, the provisions of Section 12 are applied regarding the provision of technical documentation and testing for cyber resilience."

10.7 ELECTRICAL TESTS OF PARTICULAR TYPES OF EQUIPMENT

Para 10.7.17.3.3 is amended as follows:

.3 flame retardant test shall be carried out in accordance with ~~IEC 60092-101~~ or IEC 60695-11-5:2017.

The test shall be carried out with flame application of 5 times 15 s each. Interval between each application shall be 15 s or 1 time 30 s. The equipment shall be considered to have passed the tests if burnt out or damaged part is not more than 60 mm long, no flame, no incandescence or - in the event of a flame or incandescence being present, it shall extinguish itself within 30 s of the removal of the test flame. The dripping material shall extinguish itself in such a way as not to ignite a wrapping tissue (~~aluminum foil with thickness of 0,04 mm~~);".

12 AUTOMATION EQUIPMENT

12.3 TECHNICAL DOCUMENTATION

Table 12.3.2-1. Item **C1** is amended as follows:

"

Code	Name	Description
C1	a set of documentation for programmable electronic systems computer based systems (CBS)	documentation for programmable electronic computer based systems (CBS) in compliance with Section 7, Part XV "Automation" of the Rules for the Classification and Construction of Sea-Going Ships

"

Table 12.3.2-1 is supplemented by **new item C2**:

"

C2	a set of documentation for cyber resilience	the CBS documentation in compliance with Section 3, Part XXI "Cyber Resilience" of the Rules for the Classification and Construction of Sea Going Ships
----	---	---

"

12.6 DESCRIPTION OF TESTS AND CHECKS

Table 12.6 is supplemented by new item 12.6.19:

"

12.6.19	Cyber Resilience Testing
---------	--------------------------

"

New Para 12.6.19 is introduced reading as follows:

"12.6.19 Cyber Resilience Testing.

The tests shall apply to computer based systems (CBS) of ships with the **CYBER** class symbols.

Tests of the safety functionality of CBS shall confirm compliance with the requirements of Section 3, Part XXI "Cyber Resilience" of the Rules for the Classification and Construction of Sea – Going Ships.

The tests of the equipment in the assembled form shall be carried at normal environmental conditions.

Products with codes 05413000 (460-Switch), 05414000 (460- Forwarder), 05415000 (460-Gateway) are allowed to be used as part of CBS."

EXTENT OF TECHNICAL DOCUMENTATION TO BE SUBMITTED TO RS AND THE SCOPE OF TESTS TO BE CONDUCTED

Table 1 is amended as follows:

"Table 1

Code of item of technical supervision	Item of technical supervision	Prototype of test specimen, product of stable production, in case of CTO (Form 6.8.3) or C (Form 6.5.30) issuing when CTO is missing		Product of stable production in case of C (Form 6.5.30) issuing when CTO is available	
		list of documentation	list of tests	list of documentation ¹	list of tests ²
1	2	3	4	5	6
15000000	AUTOMATION				
15010000	Integrated control system of technical means Integrated Marine Automation Systems	C1, <u>C2</u> , T1—T4, T5 ⁴ , D3, I1 ⁵	12.4.13, 12.6.1, 12.6.2 ³ , 12.6.3 ³ , 12.6.4, 12.6.5 ³ , 12.6.6 ^{3,6} , (12.6.7 — 12.6.16) ³ ₁ , 12.6.19 ⁸	C1, <u>C2</u> , T1—T4, T5 ⁴ , D3, I1 ⁵	12.4.13, 12.6.1, 12.6.2, 12.6.4, <u>12.6.19</u> ⁸
15020000	Centralized alarm and monitoring systems including computer-based systems	C1 ⁷ , <u>C2</u> ⁷ , T1—T4, D3, I1 ⁵	12.4.13 ⁷ , 12.6.1, 12.6.2 ³ , 12.6.3 ³ , 12.6.4, 12.6.5 ³ , 12.6.6 ^{3,6} , (12.6.7—12.6.16) ³ ₁ , 12.6.19 ^{7,8}	C1 ⁷ , <u>C2</u> ⁷ , T1—T4, D3, I1 ⁵	12.4.13 ⁷ , 12.6.1, 12.6.2, 12.6.4, <u>12.6.19</u> ^{7,8}
15030000	Remote control systems:				
15030100	Remote control systems of main internal combustion engines/ICE	C1 ⁷ , <u>C2</u> ⁷ , T1—T4, D3, I1 ⁵	12.4.13 ⁷ , 12.6.1, 12.6.2 ³ , 12.6.3 ³ , 12.6.4, 12.6.5 ³ , 12.6.6 ^{3,6} , (12.6.7—12.6.16) ³ ₁ , 12.6.19 ^{7,8}	C1 ⁷ , <u>C2</u> ⁷ , T1—T4, D3, I1 ⁵	12.4.13 ⁷ , 12.6.1, 12.6.2, 12.6.4, <u>12.6.19</u> ^{7,8}

*Rules for Technical Supervision during Construction of Ships
and Manufacture of Materials and Products for Ships*

Code of item of technical supervision	Item of technical supervision	Prototype of test specimen, product of stable production, in case of CTO (Form 6.8.3) or C (Form 6.5.30) issuing when CTO is missing		Product of stable production in case of C (Form 6.5.30) issuing when CTO is available	
		list of documentation	list of tests	list of documentation ¹	list of tests ²
1	2	3	4	5	6
15030200	Remote control systems of main machinery with CPP	ditto	ditto	ditto	ditto
15030300	Remote control systems of main steam turbine installations	ditto	ditto	ditto	ditto
15030400	Remote control systems of azimuth propulsion thrusters	ditto	ditto	ditto	ditto
15030500	Control systems of ship and MODU dynamic positioning systems	C1 ⁷ , <u>C2⁷</u> , T1—T4, T5 ⁴ , D3, I1 ⁵	12.4.13 ⁷ , 12.6.1, 12.6.2 ³ , 12.6.3 ³ , 12.6.4, 12.6.5 ³ , 12.6.6 ^{3,6} , (12.6.7—12.6.16) ³ , <u>12.6.19^{7,8}</u>	-	-
15030510	computer systems, their software and interfaces intended for automated control of propulsion machinery with the use of one control (joystick) or several controls	ditto	ditto	C1 ⁷ , <u>C2</u> , T1—T4, T5 ⁴ , D3, I1 ⁵	12.4.13 ⁷ , 12.6.1, 12.6.2, 12.6.4, <u>12.6.19⁸</u>

*Rules for Technical Supervision during Construction of Ships
and Manufacture of Materials and Products for Ships*

Code of item of technical supervision	Item of technical supervision	Prototype of test specimen, product of stable production, in case of CTO (Form 6.8.3) or C (Form 6.5.30) issuing when CTO is missing		Product of stable production in case of C (Form 6.5.30) issuing when CTO is available	
		list of documentation	list of tests	list of documentation ¹	list of tests ²
1	2	3	4	5	6
15030520	operator panel system with controls and data display units	C1 ⁷ , <u>C2</u> , T1—T4, D2, D3, I1 ⁵	12.4.13 ⁷ , 12.6.1, 12.6.2 ³ , 12.6.3 ³ , 12.6.4, 12.6.5 ³ , 12.6.6 ^{3,6} , (12.6.7—12.6.16) ³ , <u>12.6.19⁸</u>	C1 ⁷ , <u>C2</u> , T1—T4, D2, D3, I1 ⁵	12.4.13 ⁷ , 12.6.1, 12.6.2, 12.6.4, <u>12.6.19⁸</u>
15030530	position reference systems	C1 ⁷ , <u>C2</u> ⁷ T1—T4, D3, I1 ⁵	12.4.13 ⁷ , 12.6.1, 12.6.2 ³ , 12.6.3 ³ , 12.6.4, 12.6.5 ³ , 12.6.6 ^{3,6} , (12.6.7—12.6.16) ³ , <u>12.6.19^{7,8}</u>	-	-
15030600	remote automated control systems of electrical propulsion plants with podded azimuth thrusters	C1 ⁷ , <u>C2</u> ⁷ T1—T5, D3, I1, <u>12.6.19^{7,85}</u>	12.4.13 ⁷ , 12.6.1, 12.6.2 ³ , 12.6.3 ³ , 12.6.4, 12.6.5 ³ , 12.6.6 ^{3,6} , (12.6.7 — 12.6.16) ³ , <u>12.6.19^{7,8}</u>	C1 ⁷ , <u>C2</u> ⁷ , T1—T5, D3, I1 ⁵	12.4.13 ⁷ , 12.6.1, 12.6.2, 12.6.4, <u>12.6.19^{7,8}</u>
15030700	automated control systems of self-elevating MODU	C1 ⁷ , <u>C2</u> ⁷ , T1—T4, D3, I1 ⁵	12.4.13 ⁷ , 12.6.1, 12.6.2 ³ , 12.6.3 ³ , 12.6.4, 12.6.5 ³ , 12.6.6 ^{3,6} , (12.6.7—12.6.16) ³	C1 ⁷ , <u>C2</u> ⁷ , T1—T4, D3, I1 ⁵	12.4.13 ⁷ , 12.6.1, 12.6.2, 12.6.4, <u>12.6.19^{7,8}</u>

*Rules for Technical Supervision during Construction of Ships
and Manufacture of Materials and Products for Ships*

61

Code of item of technical supervision	Item of technical supervision	Prototype of test specimen, product of stable production, in case of CTO (Form 6.8.3) or C (Form 6.5.30) issuing when CTO is missing		Product of stable production in case of C (Form 6.5.30) issuing when CTO is available	
		list of documentation	list of tests	list of documentation ¹	list of tests ²
1	2	3	4	5	6
15030800	remote automated control system of ballast systems of column-stabilized MODU	ditto	ditto	ditto	ditto
15030900	remote automated control systems of azimuth and tunnel thrusters	<u>C2</u> ⁷ , T1-T4, D3, I1 ⁵	12.6.1, 12.6.2 ³ , 12.6.3 ³ , 12.6.4, 12.6.5 ³ , 12.6.6 ^{3,6} , (12.6.7—12.6.16) ³ , <u>12.6.19</u> ^{7,8}	<u>C2</u> , T1—T4, D3, I1 ⁵	12.6.1, 12.6.2, 12.6.4, <u>12.6.19</u> ^{7,8}
15031000	remote control and automated hull stabilization systems of high-speed craft	C1 ⁷ , <u>C2</u> ⁷ , T1-T4, D3, I1 ⁵	12.4.13 ⁷ , 12.6.1, 12.6.2 ³ , 12.6.3 ³ , 12.6.4, 12.6.5 ³ , 12.6.6 ^{3,6} , (12.6.7—12.6.16) ³ , <u>12.6.19</u> ^{7,8}	C1 ⁷ , T1 — T4, D3, I1 ⁵	12.4.13 ⁷ , 12.6.1, 12.6.2, 12.6.4, <u>12.6.19</u> ^{7,8}
15040000	Control systems of electric power plants:				
15040100	remote automated starting and stopping systems of diesel generator sets	C1 ⁷ , <u>C2</u> ⁷ , T1-T4, D3, I1 ⁵	12.4.13 ⁷ , 12.6.1, 12.6.2 ³ , 12.6.3 ³ , 12.6.4, 12.6.5 ³ , 12.6.6 ^{3,6} , (12.6.7—12.6.16) ³ , <u>12.6.19</u> ^{7,8}	C1 ⁷ , T1—T4, D3, I1 ⁵	12.4.13 ⁷ , 12.6.1, 12.6.2, 12.6.4, <u>12.6.19</u> ^{7,8}

*Rules for Technical Supervision during Construction of Ships
and Manufacture of Materials and Products for Ships*

Code of item of technical supervision	Item of technical supervision	Prototype of test specimen, product of stable production, in case of CTO (Form 6.8.3) or C (Form 6.5.30) issuing when CTO is missing		Product of stable production in case of C (Form 6.5.30) issuing when CTO is available	
		list of documentation	list of tests	list of documentation ¹	list of tests ²
1	2	3	4	5	6
15040200	remote automated starting and stopping systems of turbo generator sets	ditto	ditto	ditto	ditto
15040300	remote automated starting and stopping systems of shaft generator sets (where coupling control system is provided)	ditto	ditto	ditto	ditto
15040400	remote automated control systems of ship electric power plants	ditto	ditto	ditto	ditto
15050000	Control systems of boiler installations:				
15050100	automated control systems of main boiler installations	C1 ⁷ , <u>C2⁷</u> , T1—T4, D3, I1 ⁵	12.4.13 ⁷ , 12.6.1, 12.6.2 ³ , 12.6.3 ³ , 12.6.4, 12.6.5 ³ , 12.6.6 ^{3,6} , (12.6.7—12.6.16) ³ ₁ , <u>12.6.19^{7,8}</u>	C1 ⁷ , <u>C2⁷</u> , T1 — T4, D3, I1 ⁵	12.4.13 ⁷ , 12.6.1, 12.6.2, 12.6.4, <u>12.6.19^{7,8}</u>
15050200	remote automated control systems of auxiliary boiler installations auxiliary boiler installations	<u>C2⁷</u> , T1—T4, D3, I1 ⁵	12.6.1, 12.6.2 ³ , 12.6.3 ³ , 12.6.4, 12.6.5 ³ , 12.6.6 ^{3,6} , (12.6.7—12.6.16) ³ ₁ , <u>12.6.19^{7,8}</u>	<u>C2⁷</u> , T1—T4, D3, I1 ⁵	12.6.1, 12.6.2, 12.6.4, <u>12.6.19^{7,8}</u>

*Rules for Technical Supervision during Construction of Ships
and Manufacture of Materials and Products for Ships*

Code of item of technical supervision	Item of technical supervision	Prototype of test specimen, product of stable production, in case of CTO (Form 6.8.3) or C (Form 6.5.30) issuing when CTO is missing		Product of stable production in case of C (Form 6.5.30) issuing when CTO is available	
		list of documentation	list of tests	list of documentation ¹	list of tests ²
1	2	3	4	5	6
15050300	remote automated control systems of of exhaust gas boiler installations	ditto	ditto	ditto	ditto
15050400	remote automated control systems of hot water boiler installations	ditto	ditto	ditto	ditto
15060000	Control systems of auxiliary machinery:				
15060100	remote automated control systems of compressors	<u>C2</u> ⁷ , T1—T4, D3, I1 ⁵	12.6.1, 12.6.2 ³ , 12.6.3 ³ , 12.6.4, 12.6.5 ³ , 12.6.6 ^{3,6} , (12.6.7—12.6.16) ³ ₁ , 12.6.19 ^{7,8}	<u>C2</u> ⁷ , T1—T4, D3, I1 ⁵	12.6.1, 12.6.2, 12.6.4, <u>12.6.19</u> ^{7,8}
15060200	remote automated control systems of separators	ditto	ditto	ditto	ditto
15060300	remote automated control systems of filters	ditto	ditto	ditto	ditto
15060400	remote automated control systems of pumps (oil, fuel, cooling, etc.)	ditto	ditto	ditto	ditto

*Rules for Technical Supervision during Construction of Ships
and Manufacture of Materials and Products for Ships*

Code of item of technical supervision	Item of technical supervision	Prototype of test specimen, product of stable production, in case of CTO (Form 6.8.3) or C (Form 6.5.30) issuing when CTO is missing		Product of stable production in case of C (Form 6.5.30) issuing when CTO is available	
		list of documentation	list of tests	list of documentation ¹	list of tests ²
1	2	3	4	5	6
15060500	remote automated control systems of fuel preparation (temperature, viscosity)	C1 ⁷ , C2 ⁷ , T1—T4, D3, I1 ⁵	12.4.13 ⁷ , 12.6.1, 12.6.2 ³ , 12.6.3 ³ , 12.6.4, 12.6.5 ³ , 12.6.6 ^{3,6} , (12.6.7—12.6.16) ³ ₁ , <u>12.6.19^{7,8}</u>	C1 ⁷ , C2 ⁷ , T1—T4, D3, I1 ⁵	12.4.13 ⁷ , 12.6.1, 12.6.2, 12.6.4, <u>12.6.19^{7,8}</u>
15070000	Remote control of ships systems and remote level gauges:				
15070100	remote control systems of ballast and bilge system (together with remote controlled valves)	C1 ⁷ , C2 ⁷ , T1—T4, D3, I1 ⁵	12.4.13 ⁷ , 12.6.1, 12.6.2 ³ , 12.6.3 ³ , 12.6.4, 12.6.5 ³ , 12.6.6 ^{3,6} , (12.6.7—12.6.16) ³ ₁ , <u>12.6.19^{7,8}</u>	C1 ⁷ , C2 ⁷ , T1—T4, D3, I1 ⁵	12.4.13 ⁷ , 12.6.1, 12.6.2, 12.6.4, <u>12.6.19^{7,8}</u>
15070200	remote control systems of heel and trim systems	ditto	ditto	ditto	ditto
15070300	remote control systems of cargo piping systems of oil tankers	ditto	ditto	ditto	ditto
15070400	remote control systems of cargo piping systems of liquid gas carriers	ditto	ditto	ditto	ditto
15070500	remote control systems of ships carrying dangerous chemicals in bulk	ditto	ditto	ditto	ditto

*Rules for Technical Supervision during Construction of Ships
and Manufacture of Materials and Products for Ships*

65

Code of item of technical supervision	Item of technical supervision	Prototype of test specimen, product of stable production, in case of CTO (Form 6.8.3) or C (Form 6.5.30) issuing when CTO is missing		Product of stable production in case of C (Form 6.5.30) issuing when CTO is available	
		list of documentation	list of tests	list of documentation ¹	list of tests ²
1	2	3	4	5	6
15080000	Automation systems of deck machinery	<u>C2</u> ⁷ , T1—T4, D3, I1 ⁵	12.6.1, 12.6.2 ³ , 12.6.3 ³ , 12.6.4, 12.6.5 ³ , 12.6.6 ^{3,6} , (12.6.7—12.6.16) ³ , <u>12.6.19</u> ^{7,8}	<u>C2</u> ⁷ , T1—T4, D3, I1 ⁵	12.6.1, 12.6.2, 12.6.4, <u>12.6.19</u> ^{7,8}
15090000	Devices:				
15090100	automation devices as part of control systems listed in codes 15010000 to 15080000	T1—T4, D2, D3, I1 ⁵	12.6.1 — 12.6.5, 12.6.6 ⁶ , 12.6.7—12.6.17	-	-
15090500	oil mist detectors in crankcases of internal combustion engines (as well as internal combustion engines bearing temperature monitors or equivalent devices for the prevention of explosion in the crankcase) explosion in the crankcase)	ditto	ditto	T1—T4, D2, D3, I1 ⁵	12.6.1, 12.6.2, 12.6.4

*Rules for Technical Supervision during Construction of Ships
and Manufacture of Materials and Products for Ships*

Code of item of technical supervision	Item of technical supervision	Prototype of test specimen, product of stable production, in case of CTO (Form 6.8.3) or C (Form 6.5.30) issuing when CTO is missing		Product of stable production in case of C (Form 6.5.30) issuing when CTO is available	
		list of documentation	list of tests	list of documentation ¹	list of tests ²
1	2	3	4	5	6
15090600	ships computers and programmable logic controllers (PLC) electronic devices	ditto	ditto	-	-
15090700	electronic devices of operation of internal combustion engines	C2 ⁷ , T1—T4, D2, D3, I1 ⁵	12.6.1 — 12.6.5, 12.6.6 ⁶ , 12.6.7—12.6.17, 12.6.19 ^{7,8}	-	-
15100000	Indirect action controllers of:				
15100101	level	T1—T4, D2, D3, I1 ⁵	12.6.1 — 12.6.5, 12.6.6 ⁴ , 12.6.7—12.6.17	-	-
15100102	pressure	ditto	ditto	-	-
15100103	temperature	ditto	ditto	-	-
15100104	viscosity	ditto	ditto	-	-
15100105	speed	ditto	ditto	-	-
15110000	Sensors and indicators of:				
15110101	level	T1—T4, D2, D3, I1 ⁵	12.6.1 — 12.6.5, 12.6.6 ⁶ , 12.6.7—12.6.17	-	-
15110102	pressure	ditto	ditto	-	-
15110103	temperature	ditto	ditto	-	-
15110104	flow	ditto	ditto	-	-
15110105	salinity	ditto	ditto	-	-

*Rules for Technical Supervision during Construction of Ships
and Manufacture of Materials and Products for Ships*

Code of item of technical supervision	Item of technical supervision	Prototype of test specimen, product of stable production, in case of CTO (Form 6.8.3) or C (Form 6.5.30) issuing when CTO is missing		Product of stable production in case of C (Form 6.5.30) issuing when CTO is available	
		list of documentation	list of tests	list of documentation ¹	list of tests ²
1	2	3	4	5	6
15110106	vibration	ditto	ditto	-	-
15110107	position	ditto	ditto	-	-
15110108	sensors of position ship and external force sensors	ditto	ditto	-	-
15110110	gas concentration	ditto	ditto	-	-
15119999	other	-	-	-	-
15120000	Panels, switchboards and other enclosures for automation systems	-	-	-	-
15130000	Remote-reading measuring devices, instruments	-	-	-	-
15130100	Equipment diagnostic facilities	-	-	-	-

¹ __when CTO for the products is available and no changes to the equipment structure are made, the repeated review and approval of technical documentation are not required;

² __when CTO for the products is available and no changes to the equipment structure are made, the repeated tests in the scope of the prototype/test specimen is not required, except for 12.6.1, 12.6.2, 12.6.4;

³ __tests shall be carried out for each component of the system;

⁴ __for the integrated systems of gas carriers and dynamic positioning systems of classes 2 and 3;

⁵ __for the equipment to be installed in the explosive area;

⁶ __shall be carried out for the equipment taking into consideration the operating conditions in accordance with Table 12.6.6-1;

⁷ __when programmable logic controllers are used in the system;

⁸ __when issuing CTO, tests may not be carried out, provided that these tests are carried out when issuing certificate C.

"-" means "not applicable".

APPENDIX 3 (recommended)

CHECK-LIST OF THE SCOPE OF DOCUMENTATION

Item C1 of the Check-List is amended as follows:

"

C1	Documentation for programmable electronic computer <u>based</u> systems shall be in compliance with Section 7, Part XV "Automation" of the Rules for the Classification and Construction of Sea-Going Ships	
----	---	--

"

APPENDIX 4 (recommended)

CHECK-LIST OF THE TEST PROGRAM

Check-List is supplemented by **new item 12.6.19**:

"

12.6.19	Cyber resilience testing	
---------	--------------------------	--

"

17 EQUIPMENT FOR THE PREVENTION OF POLLUTION FROM SHIPS

**17.3 TECHNICAL SUPERVISION DURING MANUFACTURE OF POLLUTION
PREVENTION EQUIPMENT UNDER ESTABLISHED PRODUCTION CONDITIONS**

Table 17.3.1.1 is amended as follows:

"Table 17.3.1.1

Nos.	Items of technical supervision	Examination of material, blanks of assemblies and components	Verification of accompanying documents	External and internal examination	Check of welding operations	Check of component and assembly manufacture	Hydraulic tests	Check in operation
1	Equipment for the prevention of pollution by oil:							
	"..."							
	.4 oil/water interface detectors in slop tanks	+	+	+	+	+	+ ²	+
	.5 tank washing machines	+	+	+	+	+	+	+
	"..."							
3	Equipment for the prevention of pollution by garbage:							
	"..."							
	.3 garbage receptacles	±	±	±	±	±	-	-
4	Equipment for the prevention of pollution by noxious liquid substances (NLS) carried in bulk:							
	.1 ventilation equipment	+	+	+	+	+	+ ²	+
¹ When needed. ² Tightness check shall be carried out in accordance with the approved technical documentation.								

Para 17.3.1.8. The second para is amended as follows:

"~~Based on~~ In case of the satisfactory results of the type tests, Type Approval Certificates (Form 6.8.3) and Certificates of Type/Test Approval (COTO/COTI) shall be drawn up for the products specified in 1.1 — 1.4, 2.1, 3.1, and 6 of Table 17.3.1.1 in accordance with Appendix 2₂".

Paras 17.3.1.8.1 — 17.3.1.8.7 are deleted.

Para 17.3.2.4 is amended as follows:

"**17.3.2.4** ~~5 ppm bilge separators~~ Oily water fine cleaning systems shall be checked in accordance with 17.3.2.1 to 17.3.2.3 and 17.3.3.1."

Para 17.3.3.2 is deleted.

Para 17.3.6 is amended as follows:

"**17.3.6** Tank washing machines for crude oil washing and equipment for the prevention of pollution by noxious liquid substances carried in bulk."

Para 17.3.10 is amended as follows:

"**17.3.10** Sewage treatment plants, sewage comminution and disinfection plants."

New paras 17.3.14 and 17.3.14.1 are introduced reading as follows:

"**17.3.14** **Garbage receptacles.**

17.3.14.1 Garbage receptacles shall have smooth inner surfaces and shall be designed for easy discharge and cleaning. The covers shall provide for tight closure of openings for garbage loading. The removable garbage receptacles shall be provided with appliances for reliable securing on board the ship. The garbage receptacles shall meet the requirements of 2.1.1.11, Part VI "Fire protection" of the Rules for the Classification and Construction of Sea-Going Ships."

Paras 17.3.14, 17.3.14.1, 17.3.15, 17.3.15.1, 17.3.16, 17.3.16.1, 17.3.16.2, 17.3.17, 17.3.18 and 17.3.18.1 and references thereto are renumbered **17.3.15, 17.3.15.1, 17.3.16, 17.3.16.1, 17.3.17, 17.3.17.1, 17.3.17.2, 17.3.18, 17.3.19 and 17.3.19.1** accordingly.

Existing paras 17.3.17.1 and 17.3.17.2 are amended as follows:

"~~**17.3.17.1**~~ Prior to commencement of technical supervision of system, documentation specified in ~~17.3.16~~7.1 shall be submitted for approval.

~~**17.3.17.2**~~ During the survey of the system, the applicable provisions of IMO resolution MEPC. 340(77) shall be followed, the test program shall include checks listed in ~~17.3.16~~7.2."

Existing paras 17.3.19 and 17.3.19.1 are deleted.

Existing para 17.3.18.1 (renumbered 17.3.19.1) is amended as follows:

"~~**17.3.18.1**~~**19.1** Functional tests of ~~samplers~~ sampling equipment are carried out at the firm (manufacturer) ~~prior to issuing Type Approval Certificate~~. The sampling equipment intended to sample the delivered fuel at the ship's inlet bunker manifold shall meet the provisions of IMO circular MSC-MEPC.2/Circ.18."

APPENDIX 2

**TYPE APPROVAL (TEST) CERTIFICATE FOR EQUIPMENT
FOR THE PREVENTION OF POLLUTION**

Para 1 is amended as follows:

"1. Type Approval (Test) Certificate (COTO/COTI) is a document of the Register, which certifies that the PPS equipment meets the requirements of the international documents specified in Appendix 1 of these Rules. Type Approval Certificate (Form 6.8.3) shall be issued for the specified ~~documents~~ equipment in accordance with the Nomenclature (refer to Appendix 1, Part I "General Regulations for Technical Supervision" of the Rules for Technical Supervision during Construction of Ships and Manufacture of Materials and Products for Ships).".

Para 3.1 is amended as follows:

".1 Type Test Certificate:
for oil/water interface detectors in slop tanks (Form 2.4.19);
~~for sewage treatment plants (form 2.4.13);~~".

Para 3.2 is amended as follows:

".2 Type Approval Certificate:
for 15 ppm bilge separators (Form 2.4.17.1);
for 15 ppm bilge alarms 15 (Form 2.4.11.1);
for ballast and washing water discharge oil content meters (Form 2.4.16.1);
for incinerators (Forms ~~2.4.12/2.4.12.1~~);
for sewage treatment plants (Forms 2.4.13.1 — 2.4.13.4).".

APPENDIX 3

Appendix 3 "Instruction on drawing up and issue of Type Approval (Test) Certificate for the equipment for the prevention of pollution" is deleted.

18 CYBER SAFETY EQUIPMENT AND SYSTEMS

Section 18 is deleted.

Russian Maritime Register of Shipping

**Rule Change Notice
to the Rules for Technical Supervision during Construction of Ships
and Manufacture of Materials and Products for Ships**

Endorsed: 24-220453

FAI "Russian Maritime Register of Shipping"
7, Litera A, Millionnaya Ulitsa,
St. Petersburg, 191181
www.rs-class.org/en/