

COLLECTION

OF THE RULES FOR CONTAINERS

ND No. 2-090201-014-E

RULE CHANGE NOTICE

ENTERS INTO FORCE:

01.07.2024



St. Petersburg
2024

COLLECTION OF THE RULES FOR CONTAINERS

The present Rule Change Notice to the Collection of the Rules for Containers (hereinafter — RCN) has been approved in accordance with the established approval procedure and contains information on amendments and additions, except for editorial amendments. RCN amendments come into force on 1 July 2024 (excluding earlier approved amendments of an urgent matter, published by the Urgent Rule Change Notice after entering into force of the previous version of the Collection of the Rules for Containers, specified in the Revision History and highlighted in yellow).

REVISION HISTORY

GENERAL REGULATIONS FOR THE TECHNICAL SUPERVISION OF CONTAINERS

Item	Applicability	Description	Remarks
Para 1.2.1	Containers Design/manufacture/testing	Information has been specified regarding membership in IACS	
Table 2.1.3	Containers Design/manufacture Lifting set	Requirements for RS brand have been specified	
Para 3.1.4	Containers Design	Requirements for drawing up of technical documentation have been specified	

RULES FOR THE MANUFACTURE OF CONTAINERS

Item	Applicability	Description	Remarks
Part I, Paras 1.1.3 and 1.1.4	Containers Design	Requirements for non-ISO series 1 containers have been specified	
Part I, Chapter 1.3	Containers Design	Requirements for approval of containers have been specified	
Part I, Paras 1.4.2.4.1.3 and 1.4.2.4.1.4 (deleted)	Containers Testing Firms	Requirements for measurement assurance of firms have been specified	

Item	Applicability	Description	Remarks
Part I, para 1.5.1.4 , note	The firms (manufacturers) of offshore containers Quality management system	The requirements have been brought in compliance with current standards	ISO 9001 and GOST R ISO 9001 Entry-into-force date: 07.02.2024 (Urgent Rule Change Notice № 431-03 1993 от 07.02.2024)
Part I, para 1.5.2.5	The firm (manufacturers) of containers Quality management system	The requirements have been brought in compliance with current standards	ISO 9001 and GOST R ISO 9001 Entry-into-force date: 07.02.2024 (Urgent Rule Change Notice № 431-03 1993 от 07.02.2024)
Part I, Para 2.2.2	Containers Design Structure	Requirements for upper part of container structure have been specified	
Part I, Figures 2.3.2.5.1-1 and 2.3.2.5.1-2	Containers Design Structure	Requirements for load transfer areas have been specified	
Part I, Para 3.3.5	Containers Design Materials	Requirements for the value of yield strength of the material have been specified	
Part I, Para 3.3.7 (new)	Containers Design Materials	Requirements for aluminium have been introduced	

Item	Applicability	Description	Remarks
Part I, Table 3.7.1	Containers Design Welding	Requirements for welding procedures and welders have been specified	
Part I, Figure 5.6.9.1	Containers Design Fittings	Designations have been corrected	
Part II, Para 1.1.4 (deleted)	Containers Design	Information regarding platform containers has been specified	
Part II, Section 2	Containers Design Structure	Requirements for structure of general freight containers have been specified	
Part II, Para 3.1.5	Containers Testing	Requirements for scope of testing of containers have been specified	
Part III, Table 2.5.1	Containers Design Structure	Requirements for value of maximum heat transfer have been specified	
Part IV, Table 1.4.1	Containers Design Documentation	Requirements for strength calculation of tank (footnote 3) have been specified	
Part VII, Para 2.1.21	Containers Design Structure	Requirements for bolt connections have been specified	
Part VII, Para 8.2.2.2	Containers Testing	Requirements for measurement of deformations during testing have been specified	

Item	Applicability	Description	Remarks
Part VII, Para 9.5.2	Containers Design	Reference to para in Part I "Basic Requirements" has been amended	
Part VIII	Portable tanks with fiber-reinforced plastics (FRP) shell	Part has been revised, the title has been changed requirements for portable tanks with FRP shell have been specified considering IMO resolution MSC.501(105)	Entry-into-force date: 29.01.2024 (Urgent Rule Change Notice № 431-03 1990 от 29.01.2024)

RULES FOR TECHNICAL SUPERVISION DURING MANUFACTURE OF CONTAINERS, MATERIALS AND PRODUCTS FOR CONTAINERS

Item	Applicability	Description	Remarks
Table 3.2.3	Containers Manufacture Lifting set	Requirements for availability of RS brand have been specified	
Para 3.10.6 (deleted)	Containers Manufacture Lifting set	Requirements for availability of RS brand have been specified. Existing paras 3.10.7 and 3.10.8 have been renumbered 3.10.6 and 3.10.7 accordingly	
Para 5.10.1.6	Containers Manufacture	Requirements for non-destructive testing reports have been specified	
Para 5.11.2.2.4.5 (deleted)	Containers Testing	Requirements for longitudinal restraint test have been specified	
Para 5.12.1	Containers Manufacture	Requirements for assembly of containers have been specified	

RULES FOR TECHNICAL SUPERVISION OF CONTAINERS IN SERVICE

Item	Applicability	Description	Remarks
Para 2.3.3.1.2	Containers Operation Welding	Requirements for documents for welders have been specified	
Para 2.3.3.1.3	Containers Operation Welding	Requirements for documents for welding procedures have been specified	
Para 2.3.3.1.4	Containers Operation Welding	Requirements for documents for welding consumables have been specified	
Para 2.3.4	Containers Operation Firms	Requirements for firms performing residual thickness measurement have been specified	
Para 2.4.3.1.2	Containers Operation Welding	Requirements for documents for welders have been specified	
Para 2.4.3.1.3	Containers Operation Welding	Requirements for documents for welding procedures have been specified	
Para 2.4.3.1.4	Containers Operation Welding	Requirements for documents for welding consumables have been specified	
Para 3.4.2.5.7 (new)	Containers Operation Periodical survey	Requirements for survey of tank containers UN T75 have been introduced	

Collection of the Rules for Containers

Item	Applicability	Description	Remarks
Para 5.1.6	Containers Operation Marking	Requirements for marking of offshore containers have been specified	
Para 5.1.7	Containers Operation Marking	Requirements for marking of offshore containers have been specified	

GENERAL REGULATIONS FOR THE TECHNICAL SUPERVISION OF CONTAINERS

1 GENERAL

1.2 THE REGISTER ACTIVITY ON TECHNICAL SUPERVISION

Para 1.2.1 is amended as follows:

"**1.2.1** The Register is a body of technical supervision of containers. ~~Being a member of the International Association of Classification Societies (IACS),~~ The Register follows IACS decisions being guided by the provisions of the Code of Ethics of the Register. The Register Quality Management System (RS QMS) complies with applicable requirements of ISO 9001 and ISO/IEC 17020 standards, IACS QSCS and Regulation (EC) 391/2009, IMO resolution MSC.349(92), which is confirmed by the appropriate certificates."

2 TECHNICAL SUPERVISION

2.1 GENERAL

Table 2.1.3. The line (code 50020700) is amended as follows:

"

Code of item of technical supervision	Name of item of technical supervision	Group of item of technical supervision (1—5)	Branding	Remarks
50020700	Lifting set for offshore containers	3	K	

"

3 TECHNICAL DOCUMENTATION

3.1 GENERAL

Para 3.1.4 is amended as follows:

"**3.1.4** The technical documentation submitted for consideration to the Register shall be drawn up in such a way, or shall supply such particulars, so as to afford clear evidence that the requirements of the Rules are met. ~~The technical documentation shall be signed by the persons responsible for the development and duly issued.~~"

RULES FOR THE MANUFACTURE OF CONTAINERS

PART I. BASIC REQUIREMENTS

1 GENERAL

1.1 APPLICATION

Paras 1.1.3 and 1.1.4 are amended as follows:

1.1.3 Taking into account that there shall always be a need for special containers for particular transportation, containers may differ from ISO series 1 containers in dimensions and be in excess of the maximum gross masses specified in Table 2.1.2. Operation of such containers may require special arrangements and agreements. Such containers may have restrictions during operation and transportation at multi-modal use.

1.1.4 Containers differing in design and dimensions from the requirements specified in these Rules are subject to special consideration by the Register in each particular case may be reviewed by RS at the request of the customer."

Chapter 1.3 is replaced by the following text:

"1.3 APPROVAL OF CONTAINERS

1.3.1 Approval of containers means the RS decision that a design type or an individual container is safe within the terms of these Rules and is suitable for the transportation of cargoes according to designation.

1.3.2 The container manufactured and tested in accordance with the requirements of these Rules, is considered to be approved under the CSC and/or CCC and/or IMDG Code terms.

1.3.3 An application made in writing shall be submitted to the Register to obtain approval of a container by design type.

1.3.4 The application for approval for each design type of a container shall be accompanied by the technical documentation given in Table 1.4.1 of relevant Parts of the Rules for the Manufacture of Containers depending on the type of container structure.

Additional technical documentation may be required by RS if considered necessary.

Note. The test program and procedure for a prototype shall be submitted, as a rule, for review by a testing laboratory during preparations for testing the prototype.

1.3.5 A prototype of a container shall be manufactured in accordance with the technical documentation approved by RS, under the RS technical supervision at the firm (manufacturer) where manufacture of type-series products is intended. The scope of technical supervision is set forth in the Rules for Technical Supervision during Manufacture of Containers, Materials and Products for Containers.

A prototype shall be tested in accordance with the requirements of these Rules in a laboratory recognized by RS or in a testing laboratory being part of the firm (manufacturer) or at the firm (manufacturer) according to the program approved by RS.

Containers tested in accordance with procedures specified in ISO 1496 are considered tested in compliance with the CSC requirements.

1.3.6 With satisfactory results obtained in testing and surveying a prototype, RS issues COД to the firm (manufacturer).

In case of necessity, RS may in written notify the applicant that the prototype complies with the requirements of applicable CSC and/or CCC and/or IMDG Code.

1.3.7 COД shall entitle the firm (manufacturer) to affix relevant plates to every type-series container, manufactured under the RS technical supervision to the design type approved by RS.

1.3.8 RS may approve for service the containers manufactured as modifications of the previously approved design types, provided that the relevant RS procedures are fulfilled."

1.4 GENERAL REQUIREMENTS FOR FIRMS

Paras 1.4.2.4.1.3 and 1.4.2.4.1.4 are deleted.

1.5 RECOGNITION OF FIRMS (MANUFACTURERS)

Para 1.5.1.4. Note to the para is replaced by the following text:

"Note. The firm (manufacture) of offshore containers shall have valid Quality Management System (QMS) complying with ISO 9001 / GOST R ISO 9001 (current version) or an integrated management system."

Para 1.5.2.5 is replaced by the following text:

"1.5.2.5 Quality Management System.

1.5.2.5.1 The firm shall establish, document, implement and maintain a quality management system that is capable of supporting and demonstrating continuous compliance with established requirements and ensuring the quality of work performed.

The quality management system shall, at least, include the following:

- .1** quality management system documentation;
- .2** internal audits and management reviews;
- .3** control of documents and records;
- .4** requirements for personnel and their competence;
- .5** requirements for equipment and premises;
- .6** measurement assurance and technical maintenance of equipment;
- .7** requirements for submission of reporting results;
- .8** requirements for engaging subcontractors;
- .9** ensuring monitoring, review and evaluation of the QMS elements established by

the manufacturer, check and control to ensure the compliance of works with the working procedures.

1.5.2.5.2 Availability and maintenance of the quality management system in compliance with the requirements of ISO 9001/GOST R ISO 9001 (current version) or the integrated system certified by an accredited certification body or in a voluntary certification system as well as capability to support and demonstrate the consistent fulfillment of the established requirements are deemed sufficient to meet the condition.

The Register reserves the right to audit the firm's quality management system certified in the voluntary certification system."

2 GENERAL TECHNICAL DATA

2.2 POSITIONAL RELATIONSHIP OF FITTINGS

Para 2.2.2 is amended as follows:

"2.2.2 The upper faces of top corner fittings shall protrude above the top of the container by a minimum of 6 mm. By the top of the container the highest point of the container roof is meant with no allowance made for thickness of doubler plates of top rails and the roof.

Note. For containers designed for operation without stacking, the dimension from the top of the container to the upper faces of top corner fittings may be changed upon the agreement with RS.

If protective plates are provided in the vicinity of the top corner fittings, such plates shall not protrude above the upper faces of the top corner fittings and shall not extend more than 750 mm from either end of the container or on either side of intermediate fittings but may extend the full width."

2.3 BASE STRUCTURE

Figures 2.3.2.5.1-1 and 2.3.2.5.1-2 are replaced by the following:

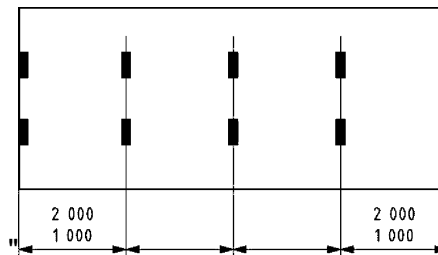

Fig. 2.3.2.5.1-1

Load transfer areas of 1CCC, 1CC, 1C and 1CX containers with 5 pairs of load transfer areas

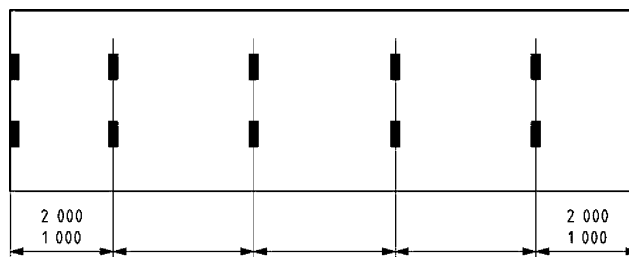

Fig. 2.3.2.5.1-2

Load transfer areas of 1BBB, 1BB, 1B, 1BX and 1CCC containers with 6 pairs of load transfer areas".

3 MATERIALS AND WELDING

3.3 MATERIALS FOR TANK CONTAINER VESSELS

Para 3.3.5. The first paragraph is amended as follows:

"3.3.5 A guaranteed value of yield strength of the material made of fine-grain steel shall not exceed 460 MPa, and a guaranteed value of upper limit of tensile strength shall not exceed 725 MPa in accordance with technical requirements for materials."

New para 3.3.7 is introduced reading as follows:

"3.3.7 For portable tanks (tank containers) UN T1-T23, aluminium may be used as a structural material only in case if it is specially provided for portable tank (tank container) in connection with a particular substance from the Dangerous Goods List or if the use of aluminium is agreed with RS.

If the use of aluminium is allowed, it shall be coated with an insulation layer to avoid significant deterioration of physical properties at heat exposure of 110 kW/m² during at least 30 min. The insulation shall remain effective at any temperatures below 649 °C and shall be coated with a material having melting temperature not less than 700 °C."

3.7 WELDING

Table 3.7.1 is amended as follows:

"Table 3.7.1

Types ¹ of containers and container products	Welding processes		Welders		Welding consumables
	Type of structure				
	Bearing	Secondary	Bearing	Secondary	
General freight containers, open top containers, non-pressurized solid bulk containers, thermal containers, products for containers	COTPC ² or WPS+ST	COTPC ² or WPS+ST	СДС ³ or WPQ ^{4,5}	СДС ³ or WPQ ⁵	COCM ⁶ +MC or C ⁷
Platform containers, platform-based containers, named-cargo containers, containers capable of being folded	COTPC ²		СДС ³		
Tank containers of all types, offshore containers of all type. Corner and intermediate fittings, shell (vessel) of tank containers, tank heads, tank shells, lifting set for offshore containers and its components				СДС ³	

¹ Welding requirements for various types of containers, including non-ISO series 1 containers, and products for containers that are not listed in this table are subject to separate consideration by the RS and depend on the thicknesses used.

² Approval of welding processes shall be carried out in accordance with the requirements of Sections 6 and 7, Part III "Technical Supervision during the Manufacture of Materials" of the Rules for Technical Supervision during the Construction of Ships and the Manufacture of Materials and Products for Ships, as applicable to containers.

³ Certification of welders shall be carried out in accordance with the requirements of Section 4, Part III "Technical Supervision during the Manufacture of Materials" of the Rules for Technical Supervision during the Construction of Ships and the Manufacture of Materials and Products for Ships.

⁴ RS reserves the right to require confirmation of certification. Such validation may include re-testing of knowledge, pre-manufacturing weld test specimens, additional non-destructive testing and/or welding production testing.

⁵ Welder performance qualification (WPQ) shall be issued more than a year before and shall provide information that the welders have practical experience in performing welding work within the last 6 months.

⁶ Approval of welding consumables shall be carried out in accordance with the requirements of Section 4, Part XIV "Welding" of the Rules for the Classification and Construction of Sea-Going Ships.

Types ¹ of containers and container products	Welding processes		Welders		Welding consumables
	Type of structure				
	Bearing	Secondary	Bearing	Secondary	
⁷ For stainless steel welding, it is allowed to use a welding consumable with a type certificate 3.1 in accordance with EN 10204. The welding consumable shall comply with the welding technologies used and shall have welding and technological characteristics that ensure the properties of welded joints within the values established by the requirements of normative and/or technical documentation.					
Notes: 1. WPQ — a document issued to a welder by a national welding institution or an authorized state body confirming the welder's qualifications.					
2. ST — with further strength testing of the prototype of the container under RS technical supervision with positive results.					
3. MC — document issued by the manufacturer, which declares the conformity of the material to the RS requirements.					
4. C — Certificate (form 6.5.30).					
5. СДС — RS Certificate on the admission of the welder.					
6. COCM — RS Certificate on the approval of the welding material.					
7. СОТПС — RS Certificate on approval of technological welding processes.					
8. СПС — specification of the welding process developed by a specialist of the firm with the appropriate qualifications and approved by the head or technical head of the organization carrying out welding work.					

5 FITTINGS

5.6 TESTING

Figure 5.6.9.1 is replaced by the following:

"

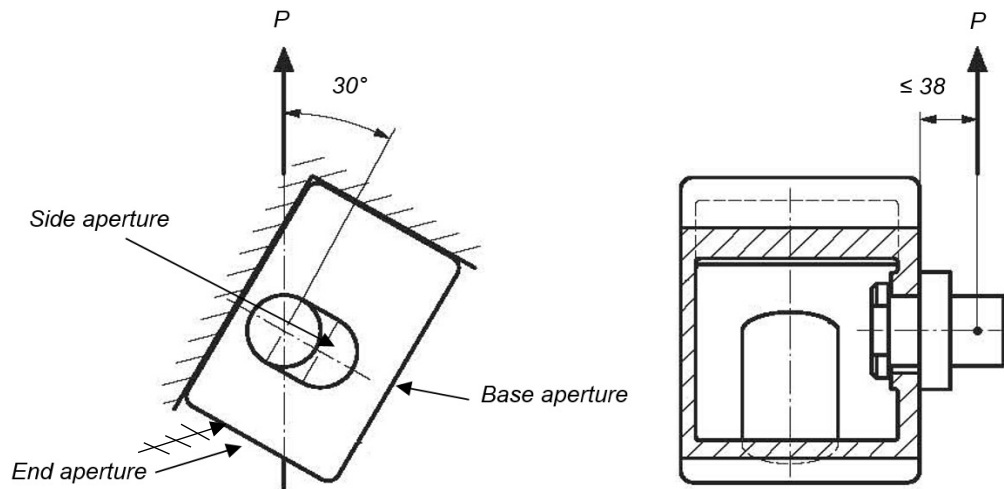

Fig. 5.6.9.1
Cargo hook lifting test 2, in mm".

PART II. GENERAL FREIGHT CONTAINERS

1 GENERAL

1.1 APPLICATION

Para 1.1.4 is deleted.

Section 2 is replaced by the following text:

"2 TECHNICAL REQUIREMENTS

2.1 INTERNAL DIMENSIONS

2.1.1 Closed containers ~~are to~~ shall have internal dimensions not less than given in Table 2.1.1.

Note. Where a top corner fitting projects into the internal space specified in Table 2.1.1, that part of the corner fitting projecting into the container shall not be considered as reducing the size of the container.

Table 2.1.1

Minimum internal dimensions of containers, mm

Dimensions acc. to ISO 6.6.8	Minimum height	Minimum width, mm	Minimum length, mm
1EEE	2655	2330	13542
1EE	2320		13542
1AAA	2655		11998
1AA	2320		11998
1A	2197		11998
1BBB	2655		8931
1BB	2320		8931
1B	2197		8931
1CCC	2655		5867
1CC	2320		5867
1C	2197		5867
1D	2197		2802

2.2 DOOR OPENING

2.2.1 Closed containers shall be provided with a door opening at least at one end.

2.2.2 The door opening, if available, shall have dimensions preferably equal to those of the internal cross-section of the container and in any case not less than the values specified in Table 2.2.2.

Table 2.2.2

Minimum dimensions of door opening, in mm

Dimension according to ISO 668	Minimum height, in mm	Minimum width, in mm
1A, 1B, 1C and 1D	2134	2286
1EE, 1AA, 1BB and 1CC	2261	
1EEE, 1AAA, 1BBB and 1CCC	2566	

2.3 DOORS

2.3.1 All doors, if available, shall open and close freely. The closing shall provide tightness. The angle of opening of each end door shall be 270°, and that of a side door shall be 180°.

Suitable stop devices shall be provided to keep the doors open."

3 TESTING

3.1 GENERAL

New para 3.1.5 is introduced reading as follows:

"3.1.5 The scope of testing, values and method of load application may be changed upon agreement with RS depending on structural particulars of the container."

PART III. THERMAL CONTAINERS

2 TECHNICAL REQUIREMENTS

2.5 THERMAL CHARACTERISTICS

Table 2.5.1 is supplemented with **new note** reading as follows:

"**Note.** Upon agreement with the customer of thermal containers, it is allowed to use other value of maximum heat transfer than that specified in the Table".

PART IV. TANK CONTAINERS

1 GENERAL

1.4 TECHNICAL DOCUMENTATION

Table 1.4.1. In **item 3.3** Footnote 1 is replaced by Footnote 3. In **item 3.5** Footnote 3 is deleted. In the Footnote cell the Footnote 3 is renumbered Footnote 1, Footnote 1 is renumbered Footnote 3. The Footnotes are reordered accordingly.

PART VII. OFFSHORE CONTAINERS

2 TECHNICAL REQUIREMENTS

2.1 GENERAL

New para 2.1.21 is introduced reading as follows:

"2.1.21 Bolt connections affecting structural and operational safety shall comply with ISO 898 or other recognized standard. Bolts shall be impact tested with V-type notch at minimum operational temperature of offshore container. Minimum value of impact energy obtained during testing of specimen having cross-section of 10 x 10 mm shall be not less than 42 J. For specimens of less size refer to 3.2.4, Part I "Basic Requirements".

Pins used in structural connections shall comply with the relevant part of EN 10083 or other recognized standard."

8 TESTING

8.2 LIFTING

Para 8.2.2.2 is amended as follows:

"**8.2.2.2** Elastic deflections during testing shall not be greater than $l/300$ of the length of any measured member."

9 LIFTING SET

9.5 MATERIALS

Para 9.5.2 is amended as follows:

"**9.5.2** The steels used for manufacture of the lifting set items shall be impact tested in accordance with the requirements of 3.2.83, Part I "Basic Requirements" at the minimum working temperature.

The minimum average impact energy in testing shall be not less than 42 J. Testing of materials for manufacture of ropes, bushes and thimbles may be exempted."

PART VIII. TANK CONTAINERS WITH FIBER-REINFORCED PLASTICS (FRP) SHELL

Part VIII is replaced by the following text:

"PART VIII. PORTABLE TANKS WITH FIBER-REINFORCED PLASTICS (FRP) SHELL

1 GENERAL

1.1 APPLICATION

1.1.1 The requirements of this Part apply to portable tanks with fiber-reinforced plastics (FRP) shell designed for the transportation of dangerous goods of classes 1, 3, 8 and 9 and sub-classes 5.1, 6.1 and 6.2 by several modes of transport.

In addition to the requirements of this Part, unless otherwise specified, the applicable requirements of the International Convention for Safe Containers (CSC) 1972, as amended, shall be fulfilled by any multimodal portable tank with FRP shell which meets the definition of a "container" within the terms of that Convention.

Note. Tank container with FRP shell is a particular case of a portable tank with FRP shell.

1.1.2 The requirements of this Part do not apply to offshore portable tanks with FRP shell.

1.1.3 Portable tanks with a FRP shell shall meet the requirements of Part I "Basic Requirements", the requirements of Part IV "Tank Containers", except for the requirements

applicable to non-refrigerated and refrigerated liquefied gases, to metal materials for the production of tank container shell, as well as the requirements of this Part.

1.1.4 Additional international and national requirements may apply to portable tanks with FRP shell used for the transportation of dangerous goods.

1.1.5 In recognition of scientific and technological advances, the technical requirements of this Chapter may be varied by alternative arrangements. These alternative arrangements shall offer a level of safety not less than that given by the requirements of this Chapter with respect to compatibility with substances transported and the ability of the FRP portable tank to withstand impact, loading and fire conditions.

For international transport, alternative arrangement portable tanks shall be approved by RS.

1.2 DEFINITIONS, EXPLANATIONS AND ABBREVIATIONS

1.2.1 The definitions, explanations and abbreviations relating to the general terminology of these Rules are given in 1.1 of the General Regulations for the Technical Supervision of Containers. Applicable definitions and explanations relating to terminology regarding portable tanks (tank containers) are given in Part IV "Tank Containers".

1.2.2 For the purpose of this Part the following definitions have been adopted.

Resin injection means an FRP construction method by which dry reinforcement (filler) is placed into a matched mould, single-sided mould with vacuum bag, or otherwise, and liquid resin is supplied to the part through the use of external applied pressure at the inlet and/or application of full or partial vacuum pressure at the vent.

Veil means a thin mate, as usual of 0,18 – 0,51 mm thickness with high absorbency used in FRP product plies where polymeric matrix surplus fraction content is required (surface evenness, chemical resistance, leakage-proof, etc.).

FRP components mean reinforcing fibers (filler), plastic binder (matrix), adhesives, and aggregates.

Structural layers are unidirectional or bidirectional FRP layers in the design of a multi-layer vessel shell that perceive loads during the operation of a tank container.

Reference sample is a sample cut out of a vessel to define the identity of series products to the test/prototype sample.

Liner means a closed part consisting of a chemically resistant layer and FRP layers supporting it.

Mate means fiber reinforcement made of randomly chopped or twisted fibers.

Filament winding means a process for constructing FRP structures in which continuous reinforcements (filament, tape, or other, either previously impregnated with a matrix material or impregnated during winding), are placed over a rotating mandrel. Generally, the shape is a surface of revolution and may include heads.

External layer means the part of the shell which is directly exposed to the atmosphere.

Witness sample means a specimen fabricated as per the procedure identical to production process of the corresponding part of FRP shell.

Flame protection layer means a layer on the outer surface of a tank shell that ensures its protection from external fire.

Parallel shell-sample means an FRP specimen, which shall be representative of the shell, constructed in parallel to the shell construction if it is not possible to use cut-outs from the shell itself. The parallel shell-sample may be flat or curved.

Fiber-reinforced plastic (FRP) means a structural material that consists of reinforcing fibers (filler), polymer binder (matrix) and is formed directly during the manufacture of a FRP container and its elements.

Design characteristics are the characteristics of FRP structures strength and rigidity obtained by testing coupon-samples with consideration of normative requirements to strength and rigidity factors, and strength criteria assumed for the design of the shell.

Roving is fiberglass harness produced by splicing several glass fibers together.

Hand layup means a process for moulding reinforced plastics in which reinforcement (filler) and plastic binder (resin) are placed on a mould.

Service equipment means measuring instruments and filling, discharge, venting, safety devices.

FRP shell means a closed part of cylindrical shape, without service and structural equipment, manholes for cleaning and examination as well as blind flanges.

Service life of portable tank with FRP shell means the number of years the portable tank with FRP shell is permitted to be in service.

Portable tank with FRP shell means a transport designed to carry dangerous goods specified in 1.1.1. The FRP portable tank includes a FRP shell and structural equipment necessary for the transport of dangerous substances. The FRP portable tank shall be capable of being filled and discharged without the removal of its structural equipment. It shall possess stabilizing members external to the shell, and shall be capable of being lifted when full. It shall be designed primarily to be loaded onto a vehicle or ship and shall be equipped with skids, mountings or accessories to facilitate mechanical handling. Road tank-vehicles, rail tank-wagons and intermediate bulk containers (IBCs) are not considered to fall within the definition for portable tanks.

Glass transition temperature (T_g) means a characteristic value of the temperature range over which the glass transition takes place.

Chemically resistant layer means a layer on the inner surface of a multilayer shell of a FRP shell that protects the shell structural layer from the chemical effect of the transported cargo.

FRP tank means a tank constructed with an FRP shell with service equipment installed on it.

Coupon sample means a FRP specimen manufactured and tested in accordance with national and/or international standards to determine design characteristics.

1.2.3 The following abbreviations and symbols are adopted in this Part.

FC – failure criteria;

DSC – differential scanning calorimetry;

DMA – dynamic thermo-mechanical analysis;

MAWP – maximum allowable working pressure;

FRP – fiber-reinforced plastics;

TMA – thermo-mechanical analysis;

HDT – heat distortion temperature.

T_g – glass transition temperature.

T_m – melting temperature.

1.3 TECHNICAL SUPERVISION

1.3.1 The list of materials and products subject to the RS technical supervision for manufacture of portable tank with FRP shell is given in Table 2.1.3 of the General Regulations for the Technical Supervision of Containers.

1.4 TECHNICAL DOCUMENTATION

1.4.1 The scope of the technical documentation, submitted for consideration, as well as the forms for confirming the compliance of the technical documentation with the RS requirements, are specified in Table 1.4.1 and may be changed upon the agreement with RS.

Table 1.4.1

No	Document name	Set ¹	Review result ²
1	Technical conditions or technical specification	I	A
2	Instruction (manual) for operation ³	II	Ag
3	Calculation of:		
	.1 portable tanks with FRP shell for strength in accordance with design cases 1 — 8, Table 3.1.3, by the finite element method or another method that ensures the reliability of the results obtained	I	Ag
	.2 portable tank with FRP shell for strength in accordance with the design case 9, Table 3.1.3, by the finite element method or another method that ensures the reliability of the results obtained	I	Ag
	.3 the required capacity of the safety devices	I	Ag
4	List of dangerous goods classes or list of goods (if required in the rules for the carriage of goods, national or international regulations) that can be transported in portable tank ⁵	II	FI
5	Prototype static test program of the tank container, if testing will be carried out at the manufacture	II	A
6	Assembly drawing of:		
	.1 portable tank with FRP shell	I	A
	.2 FRP shell (indicating the orientation and reinforcement schemes of PCM structural layers and materials used)	I	A
	.3 side and end walls	I	A
	.4 stiffening ring	II	A
	.5 cargo cooling and/or heating systems	II	A
	.6 spill box, if several and different, then each	II	A
	.7 ladder	II	A
	.8 walkways	II	A
	.9 insulation	II	A
	.10 handrails	II	A
	.11 plates (shell data, CSC and CCC)	I	A
	.12 marking	I	A
7	Drawings indicating dimensions and used materials of (if this information is not on the assembly drawings):		
	.1 corner and intermediate posts	II	A
	.2 attachment points of shell with frame	II	A
	.3 upper longitudinal, end and intermediate beams	II	A
	.4 lower longitudinal, end and intermediate beams	II	A
	.6 manlids and necks (when manufactured at the manufacturer of the portable tank with FRP shell)	II	A
	.7 element to which the CCC requirements apply	II	A
	.8 pipelines	II	A
8	Scheme with the scope of control of welded joints	II	Ag
9	Process specification for the manufacture of a FRP shell with an indication of the specifications of the materials used, components and method for monitoring technological defects	II	Ag

No	Document name	Set ¹	Review result ²
10	Specifications of raw materials and components submitted by their manufacturers	II	Ag
11	Program of incoming control of raw materials and components	II	A
12	Technical specifications for FRP shells	I	Ag
13	Instructions for FRP quality control and elimination of impermissible process defects	II	Ag
14	List of permissible process defects and operational damage in compliance with the standards, the use of which has been agreed with the Register, or with the calculation and experimental procedures approved by the Register	II	Ag
15	Test reports for coupon samples	I	FI
16	Methods for determining the design characteristics of FRP used in the shell structure	I	Ag

¹ In case of submission of technical documentation in parts, documents marked with the number (I) should be submitted with the first part. Documents marked with the number (II) may be submitted with the second and subsequent parts. The volume of technical documentation provided with the first part may be changed upon the agreement with RS.

² A — approved; Ag — agreed; FI — for information. If necessary, the documents may be approved and/or agreed subject to the implementation of the comments of the RS letter.

³ A service life inspection program shall be established, which shall be a part of the operation manual (guidelines), to monitor the condition of the portable tank with FRP shell at periodic surveys. The inspection program shall focus on the critical stress locations identified in the design analysis performed under 3.2.3. The inspection method shall take into account the potential damage mode at the critical stress location (e.g. tensile stress or interlaminar stress). The inspection shall be a combination of visual and non-destructive testing (e.g., acoustic emissions, ultrasonic evaluation, thermographic). For heating elements, the service life inspection program shall allow an examination of the FRP shell or its representative locations to take into account the effects of overheating.

⁴ Not mandatory.

⁵ RS may additionally request documents confirming the resistance of the materials of the FRP tank, its fittings and seals to cargo.

Notes: 1. Specified in this table documents may not be provided upon the agreement with RS, if all necessary information is contained in other documents, included in the set of technical documentation.
2. Documents containing information about structural elements that are not applicable to a specific container are not submitted to RS.

1.4.2 The extent of the above documentation is the minimum required.

1.5 GENERAL PROVISIONS ON DESIGN AND MANUFACTURE

1.5.1 The FRP shell shall be designed and manufactured in accordance with national and/or international standards that cover pressurized vessels considering this Part of the Rules for the Manufacture of Containers.

1.5.2 The firm (manufacturer) of FRP shell shall have a quality system complying with the requirements of 6.10.2.2.2 of the IMDG Code.

2 TECHNICAL REQUIREMENTS

2.1 GENERAL

2.1.1 Portable tank with FRP shell used for the carriage of flammable liquids of Class 3 with a flash-point of not more than 60 °C shall be constructed to ensure the elimination of static electricity from the various component parts to avoid the accumulation of dangerous charges.

2.1.1.1 The electrical surface resistance of the inside and outside of the FRP shell as established by measurements shall not be higher than 10^9 Ohm. This may be achieved by the use of additives in the resin or interlaminar conducting sheets, such as metal or carbon network.

2.1.1.2 The discharge resistance to earth as established by measurements shall not be higher than 10^7 Ohm.

2.1.1.3 All components of the FRP shell shall be electrically connected to each other and to the metal parts of the service and structural equipment and to the vehicle. The electrical resistance between components and equipment in contact with each other shall not exceed 10 Ohm.

2.1.1.4 The electrical surface-resistance and discharge resistance shall be measured initially on each manufactured portable tank with FRP shell or a specimen of the FRP shell in accordance with the procedure recognized by RS. In the event of damage to the FRP shell, requiring repair, the electrical resistance shall be re-measured.

2.1.2 The portable tank with FRP shell shall be designed to withstand, without significant leakage, the effects of a full engulfment in fire for 30 min as specified in 4.3.5.

Testing may be waived with the RS agreement, where sufficient proof can be provided by tests with comparable portable tank designs.

2.1.3 The portable tank with FRP shell shall withstand the ball drop test as specified in 4.3.4.

2.1.4 FRP tank or its compartments without vacuum valves shall withstand an external pressure exceeding the internal pressure by at least 0,04 MPa.

In this case, the FRP tank shall not have residual deformations or malfunctions, which may render the portable tank with FRP shell unfit for the designed purpose.

2.1.5 Ullage volume of a portable tank with FRP shell for liquids shall be determined depending on the kind of cargo transported; it shall, however, be minimum 2,5 % of total capacity at the ambient temperature of 50 °C.

In no case shall the portable tank with FRP shell be completely filled at the ambient temperature of 55 °C.

2.1.6 The portable tank with FRP shell intended for the transportation of liquids with kinematic viscosity not exceeding 2680 mm²/s at a temperature 20 °C shall be subdivided by surge plates into sections with maximal capacity not exceeding 7500 l if the FRP tank is filled to more than 20 %, but less than to 80 % of its total capacity.

2.1.7 The portable tank with FRP shell designed for the transportation of specific dangerous goods shall have no openings located below the cargo level.

2.2 BASE STRUCTURE of tank containers

2.2.1 The base design of the tank containers with a FRP shell shall meet the requirements of 2.1, Part IV "Tank Containers".

2.3 FRP SHELL

2.3.1 FRP shell shall have a secure connection with structural elements of the portable tank frame. FRP shell supports and attachments to the frame shell shall cause no local stress concentrations exceeding the design allowables of the shell structure for all operating and test conditions.

2.3.2 FRP shell shall be designed and made of suitable materials (compatible with cargoes carried), capable of operating within a design temperature range of -40 °C to +50 °C.

For the portable tank with FRP shell operated in more severe climatic or operating conditions (e.g. heating elements), the range of design temperatures may be amended upon agreement with RS.

2.3.3 If a cargo heating system is installed, it shall comply with 6.7.2.5.12 — 6.7.2.5.15 of the IMDG Code and with the following requirements:

.1 the maximum operating temperature of the heating elements integrated or connected to the FRP shell shall not exceed the maximum design temperature of the portable tank with FRP shell;

.2 the heating elements shall be designed, controlled, and utilized so that the temperature of the cargo carried cannot exceed the maximum design temperature of the portable tank with FRP shell or a value at which the internal pressure exceeds MAWP; and

.3 the structure of the portable tank with FRP shell and its heating elements shall allow examination of the FRP shell with respect to possible effects of overheating.

2.3.4 The FRP shell shall consist of the following elements:

liner;

construction layer;

external layer.

2.3.5 Liner.

2.3.5.1 The internal shall be designed as the primary barrier to provide for the long-term chemical resistance in relation to the cargoes to be carried, to prevent any dangerous reaction with the contents of FRP shell or the formation of dangerous compounds and any substantial weakening of the structural layers of the FRP shell owing to the diffusion of products through the liner.

Chemical compatibility shall be verified in accordance with 4.2.3.

The liner may be made both of thermoactive FRP and thermoplastic FRP.

2.3.5.2 The thermoactive FRP liner shall include:

.1 surface chemical resistant layer (gel-coat) consisting of resin and reinforced with a veil compatible with the resin and transported substances. This layer shall contain no more than 30 % of veil by weight and have a thickness of 0,25 – 0,6 mm;

.2 reinforcing layer: one layer or several layers with a total thickness of at least 2 mm that contains at least 900 g/m² of glass mat or FRP randomly reinforced with chopped fibers with a mass fraction of fiberglass of at least 30 %, unless the equivalent level of safety is demonstrated for a lower fiberglass content.

2.3.5.3 Liner made of thermoplastic FRP shall consist of the sheets that may be made of non-plasticized polyvinyl chloride (PVC-N), polypropylene (PP), polyvinylidene fluoride (PVDF), polytetrafluoroethylene (PTFE) or other material connected to the structural layers of the FRP shell.

The FRP thermoplastic sheets of the liner shall be welded together in the required shape, using a qualified welding procedure and personnel. Welded liners shall have a layer of electrically conductive media placed against the non-liquid contact surface of the welds to facilitate spark testing. Durable bonding between liners and the structural layer shall be achieved by the use of an appropriate method.

Note. For the transportation of flammable liquids, in accordance with 2.1.7, additional measures may be required to prevent the accumulation of electric charges in the inner layer.

2.3.6 Structural layer.

2.3.6.1 The structural layer of the FRP shell shall be designed to withstand the design loads in accordance with design cases 1 — 8 of Table 3.1.3.

2.3.7 External layer.

2.3.7.1 The external layer of resin or paint shall provide adequate protection of the structural layer of the FRP shell from environmental and service exposure, including to UV radiation and salt fog, and occasional splash exposure to cargoes.

Upon agreement with RS, it is allowed to use other materials that provide equivalent protection of the FRP shell wall against external factors, as mentioned above.

2.3.8 Raw materials and components.

2.3.8.1 Plastic binders (resins).

When manufacturing a mixture based on original resins, the recommendations of the manufacturer shall be followed.

In manufacturing FRP shells, the following types of resins may be used:

unsaturated polyester resins;

vinyl ester resins;

epoxy resins;

phenolic resins.

The heat distortion temperature (HDT) of the resin determined in accordance with ISO 75-1 shall be at least 20 °C higher than the maximum design temperature of the FRP shell (refer to 4.2.1) and in all cases shall be at least 70 °C.

2.3.8.2 Reinforcement material.

The reinforcement material of the structural layers shall be selected such that they meet the requirements of the structural layer.

For the reinforcement material glass fibres of at a minimum type C or ECR according to ISO 2078 shall be used. Thermoplastic veils may only be used for the liner when their compatibility with the intended contents has been demonstrated.

As agreed with RS, it is allowed to use reinforcing fibers of other types with the equivalent characteristics.

2.3.8.3 Additives.

Additives necessary for the treatment of resins, such as catalysts, accelerators, hardeners and thixotropic substances as well as materials used to improve the FRP shell, such as fillers, colours, pigments etc. shall not cause weakening of the material of FRP shell, taking into account service life and operating temperatures for which this type of the tank container construction with a FRP shell is designed.

2.3.9 FRP shell, its attachments and service equipment shall be designed to withstand the loads mentioned in design cases 1 — 8 of Table 3.1.3 without loss of contents (other than quantities of gas escaping through any degassing vents) during the design service life.

2.3.10 Construction process of FRP shell.

2.3.10.1 Filament winding, hand layup, resin infusion, or other appropriate composite production processes shall be used for construction of FRP shell.

2.3.10.2 The weight of the fibre reinforcement shall conform to that set forth in the procedure specification with a tolerance of +10 % and – 0 %. One or more of the fibre types specified in 2.3.8.2 and in the procedure specification shall be used for reinforcement of FRP shells.

2.3.10.3 The resin system shall be one of the resin systems specified in 2.3.8.1. No filler, pigment, or dye additions shall be used which will interfere with the natural colour of the resin except as permitted by the procedure specification.

2.4 SERVICE EQUIPMENT

2.4.1 Requirements for service equipment are specified in 2.3, Part IV "Tank Containers".

3 STRUCTURAL STRENGTH

3.1 DESIGN CASES

3.1.1 Strength of portable tank with FRP shell shall be calculated by finite element analysis with modelling of areas in way of connection of structural layers of FRP shell, connections of FRP shell with the frame, areas of manholes and service equipment installation.

3.2.1 FRP shells shall be of a design capable of being stress-analysed mathematically or experimentally by resistance strain gauges, or by other methods agreed with RS.

3.1.3 Design cases, allowable stresses, deformations and failure criteria (FC) of tank elements are given in Table 3.1.3.

Table 3.1.3

Design cases			Allowable stresses, deformations and failure criteria (FC)				
			Frame	Connection areas between FRP shell and frame	FRP shell	Connection areas between structural layers and FRP shell ¹	Openings in FRP shell and their strengthening
1	Separately applied static forces	in the direction of travel: twice the gross mass R multiplied by the acceleration due to gravity g ($2Rg$) ²	2.2.4, Part IV "Tank containers"	2.2.4 Part IV "Tank containers" ⁴ ; (3.2.1, 3.2.3 и 3.2.4) ⁵	3.2.1, 3.2.3, 3.2.4		
2		horizontally at right angles to the direction of travel: the gross mass R multiplied by the acceleration due to gravity g (Rg) ³					
3		vertically upwards: the gross mass R multiplied by the acceleration due to gravity g (Rg)					
4		vertically downwards: twice the gross mass R multiplied by the acceleration due to gravity g ($2Rg$)					
5		Internal testing pressure	–	–	3.2.1 — 3.2.4	3.2.6	3.2.7
6		External design pressure ⁶	–	–	3.2.1, 3.2.4, 3.2.5		
7		Filling with water up to the maximum degree	–	2.2.4 Part IV "Tank containers" ⁴ ; (3.2.1, 3.2.3 and 3.2.4) ⁵	3.2.1, 3.2.3		
8		Dynamic impact	–	2.2.4 Part IV "Tank containers" ⁴ ; (3.2.1, 3.2.3 and 3.2.4) ⁵	3.2.1, 3.2.3		

Additional (optional) design cases						
9	Lifting by upper corner fittings, lifting by bottom corner fittings, stacking, longitudinal racking, transverse racking, longitudinal restraint, transverse restraint and load-transfer area tests ⁷	2.2.4 Part IV "Tank containers"	2.2.4 Part IV "Tank containers" ⁴ ; (3.2.1, 3.2.3 and 3.2.4) ⁵	3.2.1, 3.2.3, 3.2.4	3.2.6	3.2.7
¹ Including connection joints of the end heads and the cylindrical part of the FRP shell as well as the connecting joints of the extinguishing bulkheads and partitions with the FRP shell. ² In design of portable tanks with FRP shells designed for the transportation of dangerous goods, strength of the tank, supports and attachments shall be additionally tested by the static forces in the longitudinal direction equal to $4Rg$. ³ If the direction of travel is not stated, the loads shall be taken equal to $2Rg$. ⁴ As applicable to metal elements. ⁵ As applicable to FRP elements. ⁶ In accordance with 6.7.2.2.10 of the IMDG Code. ⁷ Loads in accordance with 3.1.4, 3.4 and 3.5, Part IV "Tank Containers".						

3.2 CALCULATION CRITERIA

3.2.1 Specific provisions are laid down for certain cargoes in the applicable portable tank instruction indicated in column 13 of the Dangerous Goods List and described in 4.2.5 of the IMDG Code or by a portable tank special provision indicated in column 14 of the Dangerous Goods List and described in 4.2.5.3 of the IMDG Code.

The minimum FRP shell thickness shall not be less than that specified in 3.3.

3.2.2 At the specified test pressure (design case 5 in Table 3.1.3) the maximum tensile relative deformation measured in mm/mm in the FRP shell shall not result in the formation of microcracks, and therefore not be greater than the first measured point of elongation based fracture or damage of the resin, measured during tensile tests prescribed under 4.2.2.3.

3.2.3 For internal design pressure, external design pressure, static loads (design cases 1 — 6, Table 3.1.3) and static gravity loads caused by the contents with the maximum density and at maximum filling degree, failure criteria (FC) in the longitudinal direction, circumferential direction, and any other in-plane direction of the composite layup shall not exceed the following value:

$$FC = 1/K \quad (3.2.3-1)$$

where

$$K = K_0 \times K_1 \times K_2 \times K_3 \times K_4 \times K_5 \quad (3.2.3-2)$$

where K – shall have a minimum value of 4;

K_0 – is a strength factor. For the general design the value for K_0 shall be equal to or more than 1,5. For the portable tank with FRP shell designed for the transportation of cargoes requiring higher strength level, the value of K_0 shall be multiplied by a factor of two, unless the FRP shell is provided with protection against damage consisting of a complete metal skeleton including longitudinal and transverse structural members;

K_1 – is a factor related to the deterioration in the material properties due to creep and ageing. It shall be determined by the formula

$$K_1 = 1/\alpha\beta \quad (3.2.3-3)$$

where α – is the creep factor;

β – is the ageing factor determined in accordance with 4.2.2.5 and 4.2.2.6;

When used in calculation, factors α and β shall be between 0 and 1. Alternatively, a conservative value of $K_1 = 2$ may be applied (this does not remove the need to perform testing to determine α and β);

K_2 – is a factor related to the service temperature and the thermal properties of the resin, determined by the following equation, with a minimum value of 1:

$$K_2 = 1,25 - 0,0125(\text{HDT} - 70) \quad (3.2.3-4)$$

where HDT is the heat distortion temperature of the resin, in °C;

K_3 – is a factor related to the fatigue of the material; the value of $K_3 = 1,75$, shall be used unless otherwise agreed with RS.

For the dynamic design as outlined in 1 — 4 of Table 3.1.3 (except for 4Rg in longitudinal direction), the value of $K_3 = 1,1$ shall be used.

K_4 – is a factor related to resin curing and has the following values:

1,0 – where curing is carried out in accordance with an approved and documented process, and the quality system described under 1.5.2 includes verification of degree of cure for each portable tank with FRP shell using a direct measurement approach, such as differential scanning calorimetry (DSC) determined via ISO 11357-2;

1,1 – where thermoplastic resin forming or thermoset resin curing is carried out in accordance with an approved and documented process, and the quality system described under 1.5.2 includes verification of whichever is applicable formed thermoplastic resin characteristics or degree of cure of thermoset resin, for each portable tank with FRP shell using an indirect measurement approach according to 4.2.2.8, such as Barcol testing via ASTM D2583 or EN 59, HDT via ISO 75-1, thermomechanical analysis (TMA) via ISO 11359-1, or dynamic thermomechanical analysis (DMA) via ISO 6721 11;

1,5 – in other cases;

K_5 – is a factor related to the portable tank instruction in accordance with 4.2.5.2.6 of the IMDG Code:

1,0 – for T1 to T19;

1,33 – for T20;

1,67 – for T21 to T22.

A design validation exercise using numerical analysis and a suitable composite failure criterion shall be undertaken to verify that the plies in the FRP shell are below the allowables. Suitable composite failure criteria include, but are not limited to, Tsai — Wu, Tsai — Hill, Hashin, Yamada-Sun, Strain Invariant Failure Theory, Maximum Strain, or Maximum Stress. Other relations for the strength criteria are allowed upon agreement with RS. The method and results of this design validation exercise shall be submitted to the Register.

The allowables shall be determined using experiments to derive parameters required by the chosen failure criteria combined with factor of safety K , the strength values measured in accordance with 4.2.2.3, and the maximum elongation strain criteria prescribed in 3.2.4. The analysis of joints shall be undertaken in accordance with the allowables determined

in 3.2.6 and the strength values measured in accordance with 4.2.2.7. Buckling shall be considered in accordance with 3.2.5. Design of openings and metallic inclusions shall be considered in accordance with 3.2.7.

3.2.4 At any of the design cases as defined in 1 — 6 of Table 3.1.3, the resulting elongation in any direction shall not exceed the value indicated in Table 3.2.4 or one tenth of the elongation at fracture of the resin determined by ISO 527-2.

Table 3.2.4

Type of resin	Maximum strain in tension (%)
Unsaturated polyester or phenolic	0,2
Vinylester	0,25
Epoxy	0,3
Thermoplastic	Refer to 3.2.2

3.2.5 For the external design pressure the minimum safety factor for linear buckling analysis of the FRP shell shall be as defined in the applicable pressure vessel code but not less than three.

3.2.6 The adhesive bondlines of structural layers of the FRP shell, including connecting joints of the end heads and the cylindrical part of the FRP shell as well as the joints of the surge plates and the partitions with the FRP shell shall be capable of withstanding the loads according to Table 3.1.3. In order to avoid concentrations of stresses in the overlay lamination, the applied taper shall not be steeper than 1:6. The shear strength between the overlay laminate and the tank components to which it is bonded shall not be less than:

$$\tau = \gamma \left(\frac{Q}{l} \right) \leq \frac{\tau_R}{K} \quad (3.2.6)$$

where τ_R – is the interlaminar shear strength according to ISO 14130;
 Where no test results are available, it shall be taken as $\tau_R = 10 \text{ N/mm}^2$;
 Q – is the load per unit width of the interconnection;
 K – is the safety factor determined in accordance with 3.2.3;
 l – is the length of the overlay laminate;
 γ – is the notch factor relating average joint stress to peak joint stress at failure initiation location.

Other calculation methods for the joints are allowed following approval with RS.

3.2.7 Metallic flanges and their closures are permitted to be used in FRP shells, under design requirements of 6.7.2 of the IMDG Code. Openings in the FRP shell shall be reinforced to provide at least the same safety factors against the static and dynamic stresses as specified in design cases 1 — 6 of Table 3.1.3 as that for the FRP shell itself. The number of openings shall be minimized. The axis ratio of oval-shaped openings shall be not more than 2.

If metallic flanges or componentry are integrated into the FRP shell using bonding, then the characterisation method stated in 3.2.6 shall apply to the joint between the metal and FRP. If the metallic flanges or componentry are fixed in an alternative fashion, e.g. threaded fastener connections, then the appropriate provisions of the relevant pressure vessel standard shall apply.

3.3 MINIMUM WALL THICKNESS OF THE FRP SHELL

3.3.1 Minimum thickness of the FRP shell shall be confirmed by check calculations of the strength of the FRP shell considering strength requirements given in 3.2.3.

3.3.2 Minimum thickness of the FRP shell structural layers shall be determined in accordance with 3.2.3, however, in any case the minimum thickness of the structural layers shall be at least 3 mm.

4 TESTING

4.1 GENERAL

4.1.1 The requirements of this Section apply to portable tanks with FRP shell of all sizes, regardless of design, materials and components used.

4.2 TESTING MATERIALS AND COMPONENTS

4.2.1 Plastic binders (resins).

Tensile elongation of resin is determined in accordance with ISO 527-2. HDT shall be determined in compliance with ISO 75-1.

4.2.2 Reference FRP samples.

Prior to testing, all coatings shall be removed from the samples. If representative samples cannot be cut from the FRP shell, witness samples may be used. During the test, the following parameters shall be determined:

- .1** thickness of the structural layer of the central FRP shell wall and heads;
- .2** mass content of fiberglass in compliance with ISO 1172 or ISO 14127, as well as the orientation and arrangement of the reinforcing layers (fibers);
- .3** tensile strength, elongation at fracture and modulus of elasticity according to ISO 527-4 or ISO 527-5 for the circumferential and longitudinal directions of the samples. For areas of the FRP shell, tests shall be performed on representative laminates in accordance with ISO 527-4 or ISO 527-5, to permit evaluation of the suitability of safety factor (K). A minimum of six specimens per measure of tensile strength shall be used, and the tensile strength shall be taken as the average minus two standard deviations;
- .4** bending deflection and strength shall be established by the three-point or four-point bending test according to ISO 14125 using a sample with a minimum width of 50 mm and a support distance of at least 20 times the wall thickness. A minimum of five specimens shall be used;
- .5** creep factor α shall be determined by taking the average result of at least two specimens with the configuration described in 4.2.2.4, subject to creep in three-point or four-point bending, at the maximum design temperature for a period of 1000 h. The following test shall be undertaken for each specimen:
 - .5.1** specimen shall be placed into bending apparatus, unloaded, in oven set to maximum design temperature and allow to acclimatise for a period of not less than 60 min;
 - .5.2** specimen shall be loaded into bending apparatus in accordance with ISO 14125 at flexural stress equal to the strength determined in 4.2.2.4 divided by four. Mechanical load shall be maintained at maximum design temperature without interruption for not less than 1000 h;
 - .5.3** the initial deflection shall be measured six minutes after full load application in accordance with 4.2.2.5.2. Specimen shall remain loaded in test rig;
 - .5.4** measure the final deflection 1000 h after full load application in accordance with 4.2.2.5.2;

.5.5 the creep factor α shall be calculated dividing the initial deflection (refer to 4.2.2.5.3) by the final deflection (refer to 4.2.2.5.4);

.6 ageing factor β shall be determined by taking the average result of at least two specimens with the configuration described in 4.2.2.4, subject to loading in static three-point or four-point bending, in conjunction with immersion in water at the maximum design temperature for a period of 1000 h. The following test shall be undertaken for each specimen:

.6.1 prior to testing or conditioning, specimens shall be dried in an oven at 80 °C for a period of 24 h;

.6.2 the specimen shall be loaded in three-point or four-point bending at ambient temperature, in accordance with ISO 14125, at the flexural stress level equal to the strength determined in 4.2.2.4 divided by four. the initial deflection shall be measured 6 min after full load application and the specimen shall be removed from test rig;

.6.3 unloaded specimen shall be immersed in water at the maximum design temperature for a period of not less than 1000 h without interruption to the water conditioning period. When conditioning period has lapsed, specimens shall be removed, kept damp at ambient temperature, and tests specified in 4.2.2.6.4 shall be completed complete within three days;

.6.4 the specimen shall be subject to second round of static loading, in a manner identical in 4.2.2.6.2. Measure the final deflection 6 min after full load application. Remove specimen from test rig;

.6.5 the ageing factor β shall be calculated by dividing the initial deflection (refer to 4.2.2.6.2) by the final deflection (refer to 4.2.2.6.4);

.7 the interlaminar shear strength of the joints shall be measured by testing representative samples in accordance with ISO 14130;

.8 the efficiency of whichever is applicable of thermoplastic resin forming characteristics or thermoset resin cure and post-cure processes for laminates shall be determined using one or more of the following methods:

.8.1 direct measurement formed thermoplastic resin characteristics or thermoset resin degree of cure: glass transition temperature (T_g) or melting temperature (T_m) determined using differential scanning calorimetry (DSC) via ISO 11357; or

.8.2 indirect measurement of formed thermoplastic resin or thermoset resin degree of cure:

HDT via ISO 75-1;

T_g or T_m using thermomechanical analysis (TMA) via ISO 11359-1;

dynamic thermomechanical analysis (DMA) via ISO 6721-11;

Barcol testing via ASTM D2583 or EN 59.

4.2.3 The chemical compatibility of the liner and chemical contact surfaces of service equipment with the substances to be carried shall be demonstrated by one of the following methods. This demonstration shall account for all aspects of the compatibility of the materials of the FRP shell and its equipment with the substances to be carried, including chemical deterioration of the FRP shell, initiation of critical reactions of the contents and dangerous reactions between both.

4.2.3.1 In order to establish any deterioration of the FRP shell, representative samples taken from the shell, including any internal liners with welds, shall be subjected to the chemical compatibility test according to ISO 977 for a period of 1000 h at 50 °C or the maximum temperature at which a particular substance is approved for transport. Compared with a virgin sample, the loss of strength and elasticity modulus measured by the bending test according to EN 978 shall not exceed 25 %. Cracks, bubbles, pitting effects as well as separation of layers and liners and roughness shall not be acceptable.

4.2.3.2 Certified and documented data of positive experiences on the compatibility of filling substances in question with the materials of the FRP shell with which they come into contact at given temperatures, times and other relevant service conditions shall be provided.

4.2.3.3 Technical data published in relevant literature, standards or other sources, acceptable to RS shall be provided.

4.2.3.4 Upon agreement with the Register, other methods of chemical compatibility verification may be used.

4.2.4 FRP shell samples (e.g. from manhole cut-out) for each FRP shell manufactured shall be maintained for future inspection and FRP shell verification for a period of 5 years from the date of the initial survey and test and until successful completion of the required five-year periodic survey.

4.3 TESTS OF PORTABLE TANK WITH FRP SHELL

4.3.1 During the following tests, it is permitted to replace the regular service equipment of the tank with other equipment to ensure that the tests are carried out.

4.3.2 Prior and after the testing, the prototype of the portable tank with FRP shell shall be subjected to internal and external inspection and measurement of the main dimensions.

4.3.3 A portable tank with FRP shell with strain sensors installed in areas that require comparison of the results of FEM design calculation with test results in accordance with 3.2.3 shall be subjected to the following loads with strains recorded:

.1 when filling with water to the maximum filling degree. The measuring results shall be used to calibrate the design calculations according to 3.2.3;

.2 when filling with water to the maximum filling degree and subjected to static loads in all three directions mounted by the base corner castings without additional mass applied external to the shell. For comparison with the design calculation in accordance with 3.2.3 the strains recorded shall be extrapolated in relation to the quotient of the accelerations required in design cases 1 — 4 of Table 3.1.3 and measured;

.3 when filling with water and subjected to the internal test pressure. Under this load, the FRP shell shall exhibit no visual damage or leakage. The stress corresponding to the measured strain level shall not exceed the minimum factor of safety calculated in 3.2.3 under any of these loading conditions.

4.3.4 The portable tank with FRP shell shall be subjected to ball drop testing in compliance with 6.6 in EN 976-1. Tests shall be performed on a void tank without water residues. No visible damage is permitted inside or outside the tank.

4.3.5 A portable tank with FRP shell filled with water up to 80 % of its maximum capacity shall be subjected to full engulfment in flame for 30 min using an open reservoir filled with fuel oil or any other type of fuel with the same fire effect.

The fire shall be equivalent to a theoretical fire with a flame temperature of 800 °C, emissivity of 0,9 and to the tank a heat transfer coefficient of 10 W/(m²K) and surface absorptivity of 0,8.

A minimum net heat flux of 75 kW/m² shall be calibrated according to ISO 21843.

The reservoir dimensions shall exceed those of the portable tank with FRP shell by at least 50 cm for each side, and the distance between the fuel level and the FRP shell shall be 50 to 80 cm.

The rest of the portable tank with FRP shell below the liquid level, including openings and closures, shall remain leakproof, except for drips.

4.3.6 The portable tank with FRP shell which meets the definition "container" within the terms of CSC, shall be tested in compliance with the requirements of Section 3, Part IV "Tank Containers" (except for 3.7.7 and 3.8).

4.4 INSPECTIONS

4.4.1 Before being put into service, the portable tank with FRP shell and its equipment shall be inspected in compliance with the requirements of 3.10, Part IV "Tank Containers".

5 MARKING

5.1 MANDATORY MARKING

5.1.1 Portable tank with a FRP shell which meets the definition "container" within the terms of CSC, shall be marked in accordance with the requirements specified in Section 4, Part I "Basic Requirements" and Section 4, Part IV "Tank Containers".

5.1.2 Requirements of 4.3, Part IV "Tank Containers" are applicable to data identification plate on portable tank with FRP shell with the following modifications:

.1 in 4.3.1.6.1, Part IV "Tank Containers" to specify "Shell structural material: Fibre-reinforced plastic", the reinforcement fibre e.g. "Reinforcement: E-glass", and resin e.g. "Resin: Vinyl Ester";

.2 4.3.1.6.3 of Part IV "Tank Containers" is not applicable;

5.1.3 Upon agreement with the customer, a metal plate with description of the permissible operational damage to a FRP shell may be additionally installed."

RULES FOR TECHNICAL SUPERVISION DURING MANUFACTURE OF CONTAINERS, MATERIALS AND PRODUCTS FOR CONTAINERS

3 TECHNICAL SUPERVISION DURING MANUFACTURE OF PRODUCTS

3.2 TECHNICAL SUPERVISION

Table 3.2.3. Line 1.14 is amended as follows:

No.	Item of technical supervision	Verification						control of flow detection	tests	marking	branding
		technical documentation	material and visual examination	matching of parts	welding operations	manufacture of parts and assemblies	assembly of products				
		3.3	3.4	3.5	3.6	3.7	3.8	3.9	3.10		
1.14	lifting set for offshore containers	+	+		+	+	+	+	+	+	

3.10 MARKING AND BRANDING

Para 3.10.6 is deleted. Existing paras 3.10.7 and 3.10.8 are renumbered 3.10.6 and 3.10.7 accordingly.

5 TECHNICAL SUPERVISION DURING MANUFACTURE OF CONTAINERS

5.10 FLAW DETECTION

Para 5.10.1.6 is amended as follows:

"5.10.1.6 Reports confirming inspection results shall contain the information specified in 3.2.7, Part XIV "Welding" of the Rules for the Classification and Construction of Sea-Going Ships sufficient for RS (for example, standard for quality assessment of welds, full name of specialist who conducted the non-destructive testing, test results)."

5.11 TESTS

Para 5.11.2.2.4.5 is deleted.

5.12 FINAL ASSEMBLY OF CONTAINER

Para 5.12.1 is amended as follows:

"**5.12.1** Correct installation of fittings and thermal insulation shall be checked during final assembly of the container. Herewith painting and/or application of thermal insulation for tank containers and offshore containers shall be carried out only after testing."

RULES FOR TECHNICAL SUPERVISION OF CONTAINERS IN SERVICE

2 RECOGNITION AND AUDIT OF FIRMS

2.3 RECOGNITION AND AUDIT OF FIRMS

Paras 2.3.3.1.2 — 2.3.3.1.4 are amended as follows:

"2.3.3.1.2 Welder Approval Test Certificates Documents for welders considering requirements of 3.7, Part I "Basic Requirements" of the Rules for the Manufacture of Containers;

2.3.3.1.3 Welding procedures considering requirements of 3.7, Part I "Basic Requirements" of the Rules for the Manufacture of Containers;

2.3.3.1.4 Documents for applicable welding consumables considering requirements of 3.7, Part I "Basic Requirements" of the Rules for the Manufacture of Containers;".

Para 2.3.4 is amended as follows:

"**2.3.4** Special requirements to firms performing residual thickness measurements of tank container shells (codes 40000001, ~~40000002~~, and 40000006)."

2.4 RECOGNITION OF FIRMS

Paras 2.4.3.1.2 — 2.4.3.1.4 are amended as follows:

"2.4.3.1.2 Welder Approval Test Certificates Documents for welders considering requirements of 3.7, Part I "Basic Requirements" of the Rules for the Manufacture of Containers.

2.4.3.1.3 Welding procedures (for code 40000001) considering requirements of 3.7, Part I "Basic Requirements" of the Rules for the Manufacture of Containers.

2.4.3.1.4 Documents for applicable welding consumables considering requirements of 3.7, Part I "Basic Requirements" of the Rules for the Manufacture of Containers."

3 PERIODICAL SURVEYS

3.4 SURVEY OF TANK CONTAINERS

New para 3.4.2.5.7 is introduced reading as follows:

"**3.4.2.5.7** For tank containers UN T75 (if applicable) the readings of the vacuum meter shall be taken."

5 MARKING AND BRANDING

5.1 BRANDING

Para 5.1.6 is supplemented with the text reading as follows:

"The date and mark may be also indicated on the sticker of the approved type without RS branding."

Para 5.1.7 is supplemented with the text reading as follows:

"The date and mark may be also indicated on the sticker of the approved type without RS branding."

Russian Maritime Register of Shipping

Rule Change Notice to the Collection of the Rules for Containers

Endorsed: 24-85099

FAI "Russian Maritime Register of Shipping"
8, Dvortsovaya Naberezhnaya,
191181, St. Petersburg, Russian Federation
www.rs-class.org/en/