

RULES

FOR THE CLASSIFICATION AND CONSTRUCTION OF SUBSEA PRODUCTION SYSTEMS

ND No. 2-090601-003-E



St. Petersburg

RULES FOR THE CLASSIFICATION AND CONSTRUCTION OF SUBSEA PRODUCTION SYSTEMS

The present version of the Rules for the Classification and Construction of Subsea Production Systems of Russian Maritime Register of Shipping (RS, the Register) has been approved in accordance with the established approval procedure and comes into force on 10 March 2026.

The present version is based on the version dated 1 January 2025 and Rule Change Notice No. 323-05-2078 taking into account the amendments and additions developed immediately before publication (refer to the [Revision History](#)).

REVISION HISTORY¹

For this version, there are no amendments to be included into the Revision History.

¹ With the exception of amendments and additions introduced by Rule Change Notices (RCN), as well as of misprints and omissions.

PART I. GENERAL REGULATIONS FOR TECHNICAL SUPERVISION

1 DEFINITIONS AND ABBREVIATIONS

Terms, definitions and explanations relating to the general terminology used in normative documents of the Russian Maritime Register of Shipping (hereinafter referred to as "RS", "the Register") are given in 1.1 of Part I "Classification" of the Rules for the Classification and Construction of Sea-Going Ships and in Part I "General Regulations for Technical Supervision" of the Rules for Technical Supervision during Construction of Ships and Manufacture of Materials and Products for Ships.

For the purpose of the Rules for the Classification and Construction of Subsea Production Systems (hereinafter referred to as "the Rules"), the definitions given in:

Part I "Classification" of the Rules for the Classification and Construction of Mobile Offshore Drilling Units (hereinafter referred to as "the MODU Rules");

Part I "Classification" of the Rules for the Classification and Construction of Fixed Offshore Platforms (hereinafter referred to as "the FOP Rules");

Part I "Classification" of the Rules for the Classification and Construction of Floating Offshore Oil-and-Gas Product Units (hereinafter referred to as "the FPU Rules");

Part I "General Regulations for Technical Supervision" of the Rules for the Oil-and-Gas Equipment of Floating Offshore Oil-and-Gas Product Units, Mobile Offshore Drilling Units and Fixed Offshore Platforms (hereinafter referred to as "the OGE Rules");

Section 1 "General" of the Rules for the Classification and Construction of Subsea Pipelines (hereinafter referred to as "the SP Rules");

Section 1 "General" of the Guidelines on Technical Supervision during Construction and Operation of Subsea Pipelines (hereinafter referred to as "the SP Guidelines");

"General Regulations for the Classification and Other Activity relating to Manned Submersibles and Ship's Diving Systems" of the Rules for the Classification and Construction of Manned Submersibles and Ship's Diving Systems (hereinafter referred to as "the MS/DS Rules");

Section 2 of Part I "General" of the Rules for Planning and Execution of Marine Operations (hereinafter referred to as "the MO Rules");

and the following definitions and abbreviations (unless expressly provided otherwise in particular parts of the Rules) have been adopted.

1.1 DEFINITIONS

Barrier is an element/system/device forming part of a pressure-containing envelope which is designed to prevent unintentional flow of produced/injected fluids, particularly to the external environment.

Quick-action coupling is an end termination designed to connect hoses and/or umbilicals to the SPS items including pig launchers/receivers by a remotely operated vehicle.

Diving system is the whole plant of equipment designed for the conduct of diving operations using saturation diving technique and long-term life support under air or breathing gas mixture pressure.

Flow line is the subsea pipeline which directs well fluids flows from the wellhead to the first process unit (vessel).

High integrity pressure protection system (HIPPS) is a system for protection downstream components against high pressure from wells.

Sea (water area) depth is the vertical distance measured from the seabed to the average water level plus the total height of astronomical and storm tides.

Date of SPS construction is the day, month and year specified in the Report of the acceptance committee, drawn up in accordance with the requirements of national supervisory bodies.

Template is a structure with conical flared sockets for drilling subsea wells and pits for fastening piles (ensures spacing of wells necessary to install and repair wellhead setup).

Choke valve is a unit of pressure control equipment used to restrict and regulate the flow of well fluids to maintain a desired pressure and flow rate.

Protective structure is the structure designed to protect the subsea equipment of the SPS from damage by accidental loads (impact of ice formations, dropped objects, anchors, fishing gear, etc.).

Pig launcher/receiver is an equipment designed for receiving and/or launching of cleaning, intelligent, separation and sealing pigs in the flow of the conveyed working medium of the subsea pipeline.

Umbilical termination head is a mechanism for mechanically, electrically, optically and/or hydraulically connecting an umbilical or jumper bundle to a subsea production system.

Manifold is a collection of pipes with the necessary valves, assembled in such a way as to allow selective direction of flows.

Production tubing is a tubular used in a wellbore, through which production fluids are produced.

Subsea production system operator is an organization (company) which physically operates the subsea production system.

Remotely operated vehicle (ROV) is a submersible craft, remotely controlled and powered via an umbilical, capable of moving in the depth of water and/or over the sea bed and used to perform underwater engineering works.

Subsea production system is subsea devices, systems and equipment designed to produce well fluid on offshore oil and gas fields using subsea well completion.

Riser/riser system is a piping/piping system, vertical, as a rule, connecting the subsea production system with surface oil production equipment.

Connector is a device for piping/umbilical connection and fixation to the subsea production system, providing leak-tightness and mechanical strength of the assembly.

Pigs (cleaning pigs, geometry tools and scrapers) are gauges, intelligent pigs and other devices transferred in the pipeline by the flow of conveyed working medium and intended for cleaning and/or inspection of the pipeline.

Tubing head is equipment, from which the production oil well tubing is suspended.

Wellhead assembly is wellhead equipment providing wellhead sealing and well fluid flow control.

Wellhead equipment is a technical facility or a set of technical facilities installed on a wellhead of the oil or gas pool during its construction, operation or repair and designed to perform one or several functions associated with wellhead sealing.

X-mas tree is an assembly of control valves (pressure gauges and choke valves), spools and fittings connected to the top of a well to direct and control the flow of formation fluids from the well.

Umbilical is an element of the subsea production system, consisting of a group of electrical cables, optical fibre cables, hoses, metal/composite pipes, either of their own or with combinations with each other and protected with polymer/steel sheath.

1.2 ABBREVIATIONS

AUV — Autonomous underwater vehicle;
DS — Diving system;
FOP — Fixed offshore platform;
PT — Production tubing;
ESD — Emergency shut-down;
MODU — Mobile offshore drilling unit;
SPS — Subsea production system;
FPU — Floating offshore oil-and-gas product unit;
ROV — Remotely operated vehicle;
WHA — Wellhead assembly;
AMV — Annulus master valve;
ASV — Annulus swab valve;
AWV — Annulus wing valve;
BOP — Blowout preventer;
CIV — Chemical injection valve;
CIU — Chemical injection unit;
COG — Center of gravity;
CV — Control valve;
DCS — Distributed control system;
DCV — Directional control valves;
DHPT — Digital hydraulic pressure transformation;
EDP — Emergency disconnect package;
EPU — Electrical power unit;
ESD — Emergency shut-down;
EXT — Extended;
FAT — Factory acceptance test;
HIPPS — High integrity pressure protection system;
HPU — Hydraulic power unit;
HXT — Horizontal X-tree;
ICB — Integrated control buoy;
ILT — In-line tee;
LPMV — Lower production master valve;
LRP — Low riser package;
MCS — Master control station;
NPTF — National pipe tape fuel;
PGB — Permanent guide base;
PLEM — Pipeline end manifold;
PLET — Pipeline end termination;
PSV — Production swab valve;
PWV — Production wing valve;
ROV — Remote operated vehicle;
SCM — Subsea control module;
SCPS — Subsea cable power supply;
SCSSV — Surface controlled subsurface safety
SCSSV — Surface controlled subsurface safety valve;
SEM — Subsea electronic module;
SPARCS — Subsea powered autonomous remote control system;
SPDS — Subsea power distribution system;
STD — Standard;
SUDU — Subsea umbilical distribution unit;

SUT — Subsea umbilical termination;
TGB — Temporary guide base;
UPMV — Upper production master valve;
UPS — Uninterrupted power supply;
UTH — Umbilical termination head/fitting;
VXT — Vertical X-tree;
XOV — X-cross over valve.

2 APPLICATION

2.1 GENERAL

2.1.1 These Rules apply to the following SPS elements:

foundations and bases;
protective structures;
subsea wellhead equipment;
flowlines, subsea pipelines and risers;
umbilicals;
well fluid gathering and treatment systems;
power supply systems;
systems for monitoring, control and emergency protection.

2.1.2 The requirements contained in these Rules refer to the following:

classification of SPS;
list of documentation for the SPS required during review of the oil-and gas field;
construction projects;
list of the nomenclature of items of the Register technical supervision;
general requirements for designing of SPS including design load values;
Register technical supervision during construction and operation of the SPS, as well as during manufacture of materials and products for them;
procedures of the Register technical supervision for the SPS elements listed in [2.1.1](#);
safety assessment of SPS.

2.1.3 The Rules apply during design, construction, operation and confirmation of compliance of the SPS with regard to the set level of safety, of no environmental pollution when performing operations on production, gathering, treatment, processing and transportation of well fluids, as well as during assessment of risks of the relevant critical events.

2.1.4 The Rules establish classes of the SPS which may be assigned to these objects if they comply with the requirements of these Rules and have to be confirmed provided the Register performs technical supervision.

2.1.5 The Rules may be used by all the organizations and firms which activities are associated with the SPS design and manufacture, construction and development of hydrocarbon fields on the continental shelf irrespective of their departmental affiliation and form of ownership. In case an organization or a firm has decided to apply the Rules on a voluntary basis, all the requirements of the Rules shall be met.

2.1.6 The Rules may be applied to the SPS built without the Register technical supervision, for the purpose of survey, class assignment, confirmation of compliance and technical supervision in service. In such cases, the Register has a right to require performance of special tests, as well as to reduce intervals between periodical surveys or extend the scope of these surveys. The special tests mean such tests which may be specified by the RS when classing the SPS, in addition to tests conducted during periodical surveys. The content of the special tests is specified by the RS.

2.1.7 The SPS constructed and installed according to other rules, regulations and standards may be approved by the Register alternatively or in addition to the Rules. In well-grounded cases, the SPS shall be brought into line with the Rules within the time limits agreed upon with the Register.

2.1.8 These Rules do not apply to subsea structures, systems and equipment intended for drilling wells.

If the SPS equipment includes foundations and devices intended for connection to drilling equipment for drilling additional wells with subsea completion after commissioning of the SPS, these Rules apply to these foundations and devices but do not apply to the drilling equipment to be connected.

2.1.9 The Rules apply to subsea structures, systems and equipment used to introduce into a well with subsea completion of special tool intended for downhole performance, but do not cover this tool.

2.1.10 The Rules apply to subsea structures, systems and equipment intended to ensure surveys of the SPS elements and engineering underwater works thereon with the use of diving equipment and/or submersibles but do not cover the diving equipment and submersibles.

2.2 REQUIREMENTS OF NATIONAL SUPERVISORY BODIES

2.2.1 The fulfillment of the requirements of the Rules does not discharge of meeting the requirements of national supervisory bodies for the SPS including those for:

oil-and-gas equipment for production, processing and transportation of well fluids on the sea shelf at the stages of designing, manufacture, certification, installation, welding, testing and operation and utilization of this equipment;

underwater potentially hazardous objects in the internal waters and territorial seas of the Russian Federation.

3 CLASS OF THE SUBSEA PRODUCTION SYSTEM

3.1 GENERAL

3.1.1 Assignment of the Register class means confirmation that the SPS complies with the applicable requirements of the Rules and is put under technical supervision for a specified period with performing all the surveys stipulated by the Register for confirmation of the class. Assignment of the Register class to the SPS is confirmed by issuance of a Classification Certificate of a set form.

3.1.2 The materials and products used shall be subjected to necessary surveys and tests during manufacture in accordance with the procedure established by the Register and within scope according to the requirements of [Section 7](#).

3.1.3 Confirmation of the class means that the Register confirms compliance of the SPS technical condition in service with the assigned class and extension of the Register technical supervision for an established period.

3.1.4 The SPS class shall be assigned or renewed by the Register, as a rule, for a five-year period. However, in sound cases the Register may assign or renew a class for a lesser period.

3.1.5 The Register may assign class to SPS upon completion of construction, as well as assign or renew the class to the SPS in service.

3.1.6 If the SPS is not subjected to mandatory survey within specified terms; unless it has been subjected to survey after repair; if alterations not agreed with the Register have taken place in the construction, or when repair of the SPS has been performed without technical supervision by the Register, the SPS Classification Certificate shall become invalid and classification is automatically suspended.

3.1.7 Withdrawal of class means termination of the Register technical supervision and reinstatement thereof is subject of special consideration by the Register. The Register may withdraw the class or refuse to perform technical supervision in cases when the SPS owner or operating organization regularly break the Rules, as well as in cases when the party, which has made Agreement on Survey (CO) with the Register, violates it.

3.2 CLASS NOTATION

3.2.1 The class notation assigned to a SPS by the Register consists of the character of classification and additional distinguishing marks and descriptive notations defining structure and purpose of the SPS.

3.2.2 The character of classification assigned to a SPS by the Register consists of the following distinguishing marks: SPS⊕, SPS★ or SPS▲.

Depending on the supervisory body under whose supervision the SPS has been constructed, the character of classification is established in the following way:

SPS constructed according to the Rules and under supervision of the Register are assigned a class notation with the character of classification SPS⊕;

SPS constructed according to the Rules and under supervision of another classification body or national supervisory body recognized by the Register are assigned a class notation with the character of classification SPS★;

SPS constructed without the supervision of a classification body or national supervisory body recognized by the Register are assigned a class notation with the character of classification SPS▲.

3.2.3 Two groups of additional distinguishing marks are added to the character of classification:

3.2.3.1 Distinguishing marks corresponding to the types of the well fluids produced:

G — gas;

L — liquid or two-phase fluid;

3.2.3.2 Distinguishing marks corresponding to the purpose of the SPS item:

WS — single subsea wellhead equipment;

WC — cluster subsea wellhead equipment;

M — manifold;

WCM — cluster subsea wellhead equipment with manifold;

PLEM — pipeline end manifold;

PLET — pipeline end termination;

RB — riser basement;

S — separator (irrespective of purpose and operating principle)¹;

SCPS — subsea cable power supply;

SPDS — subsea power distribution system;

B — booster (irrespective of purpose and operating principle)¹;

Cm — gas compressor¹;

CI — cooler¹;

Sc — scrubber¹.

3.2.4 The following descriptive notations are added to the character of classification and distinguishing mark:

3.2.4.1 When producing well fluids with corrosive properties (hydrogen sulphide) — corrosion-active.

3.2.4.2 Depending on the availability and type of protective structures defining the level of complexity in terms of access to the equipment and the way it is maintained:

unprotected — for SPS without protective structures;

protected — for SPS with untight protective structures;

protected caisson — for SPS with untight protective structures using a caisson embedded in seabed soil;

tight protected — for SPS with tight protective structures relieved of hydrostatic pressure;

¹ When a separator, a booster or a compressor are combined in a common unit, the additional distinguishing mark represents combination of appropriate designations; in case where equipment for injecting water into formation is provided, a designation **I** is added to the mentioned one (e.g. **SBI**).

tight protected caisson — for SPS with tight protective structures of wellhead equipment, relieved of hydrostatic pressure, using caisson embedded in seabed soil;

tight protected normobaric — for SPS with tight normobaric protective structures of wellhead equipment.

tight protected normobaric caisson — for SPS with tight normobaric protective structures of the wellhead equipment, using a caisson embedded in seabed soil.

3.2.4.3 Depending on the monitoring and control system used:

hydraulic;

electric;

electrohydraulic;

multiplex;

autonomous.

3.2.4.4 Correspondence to a particular operational geographic region (water area), working pressure, MPa, and working temperature, °C.

Example: SPS⊗G PLET, corrosion-active, unprotected, electrohydraulic, Barents Sea, 19 MPa, 50 °C.

4 GENERAL REQUIREMENTS FOR TECHNICAL SUPERVISION

4.1 GENERAL

4.1.1 The technical supervision of the SPS is performed with the aim of classification thereof, verification of the class maintenance conditions and compliance of the SPS with the Register requirements in the process of design, construction, marine operations during construction (installation), commissioning, operation, modernization, repair, conservation and utilization.

4.1.2 The Register activities on SPS classification, technical supervision at the stages indicated in [4.1.1](#) are carried out on the basis of contracts with the customers made on a voluntary basis.

4.1.3 The technical supervision of the SPS includes verification of its conformity to the Register requirements:

during review and approval (agreement) of technical documentation;

survey of items of technical supervision at the stages of manufacture, construction, operation including modernization and repair.

4.1.4 The Register technical supervision during design, construction and operation of the SPS, as objects of the field construction of the sea shelf, is carried out along with the procedures for supervision of these objects performed by the supervisory bodies of the RF, in accordance with the requirements of the RF legislation ([refer to 2.2](#)).

4.1.5 The items of the Register technical supervision and the technical requirements thereto are defined by the Rules and listed in the Nomenclature of Items of the Register Technical Supervision of the SPS ([refer to Table 6.1](#)).

4.1.6 During technical supervision of the SPS the Register may permit use of normative and technical documents of foreign classification societies, other recognized national and international regulations, rules and standards.

4.1.7 Construction of the SPS and installation thereof shall be carried out in compliance with technical documentation approved (agreed) by the Register.

4.1.8 In other respects, the general provisions for technical supervision of the SPS shall comply with the requirements of Section 2 of Part I "General Regulations for Technical Supervision" of the Rules for Technical Supervision during Construction of Ships and Manufacture of Materials and Products for Ships.

4.2 SERVICES RENDERED DURING TECHNICAL SUPERVISION

4.2.1 During technical supervision of the SPS the Register performs:

review of technical documentation ([refer to Section 5](#)) and provides a conclusion on the possibility of assigning a class to the SPS, which confirms compliance with requirements of the Rules ([refer to Section 3](#));

approval of individual materials and products for the SPS listed in the Nomenclature of Items of the Register Technical Supervision of the SPS with issue of a Certificate (C, C3, CTO — [refer to 7.1, 7.2](#));

recognition of manufacturers of materials and products for the SPS with issue of a Recognition Certificate for Manufacturer (СПИ — [refer to 7.4](#));

approval of welding consumables and welding procedures with issue of a Certificate of Approval for Welding Consumables, Welding Procedure Approval Test Certificate and certification of welders (COCM, COTПС — [refer to 7.6](#));

recognition of testing laboratories with issue of a Recognition Certificate of Testing Laboratory (СПЛ — [refer to 7.3](#));

recognition of service suppliers with issue of a Recognition Certificate (СП — [refer to 9.2](#));

audit of firms with issue of a Certificate of Firm Conformity (ССП — [refer to 7.5](#));

technical supervision of the SPS during their manufacture and construction (installation);

technical supervision of the SPS in service, as well as during modernization and repair.

4.2.2 Based on the results of technical supervision the Register shall issue to the items of technical supervision the following documents in accordance with a set form, which certify compliance of the item of technical supervision with the Register requirements, as well as its construction under the Register technical supervision:

Certificate for a particular material or product (C, C3) — a document certifying the conformity of the particular materials, products of groups of products with the requirements of the RS rules and normative documents;

Type Approval Certificate (CTO) — a document certifying the conformity of types of materials, products or groups of products with the requirements of the RS rules;

Recognition Certificate for Manufacturer (СПИ) — a document certifying the recognition by the Register of the firm as manufacturer of materials and products subject to the Register technical supervision;

Certificate of Firm Conformity (ССП) — a document certifying the conformity of the firm with the RS requirements in carrying out the work indicated in the request;

Recognition Certificate (СП) — a document certifying the recognition of service supplier rendering services (carrying out work) in compliance with the RS requirements;

Recognition Certificate of Testing Laboratory (СПЛ) — a document certifying the competence of the laboratory in carrying out certain types of tests of the materials;

Certificate of Approval for Welding Consumables (COCM) and Welding Procedure Approval Test Certificate (COTПС).

4.2.3 The basic requirements for issue and validity period of the Register Certificates shall comply with Section 3 of Part I "General Regulations for Technical Supervision" of the Rules for Technical Supervision during Construction of Ships and Manufacture of Materials and Products for Ships.

4.3 REQUESTS, CONTRACTS AND AGREEMENTS ON TECHNICAL SUPERVISION

4.3.1 To carry out works specified in [4.2.1](#) a firm shall apply to the Register with a written request to perform technical supervision with a guarantee of payment for the Register services and reimbursement of the Register expenses, as well as with the confirmation of familiarization and agreement with the General Conditions for Rendering Services by the Register, which are constituent and integral part of all the contracts concluded by the Register.

4.3.2 The request shall provide the information to an extent sufficient for review and execution thereof.

4.3.3 Upon reviewing the request, depending on the particular conditions of the forthcoming technical supervision (scope and item of supervision, duration, etc.) the Register, being guided by the regulations in force, decides of the necessity to conclude a contract on technical supervision, compiled as a single document, or carries out technical supervision based on the request without concluding a contract.

4.3.4 The contract on technical supervision by the Register, which is compiled as a single document, specifies the items of technical supervision and regulates mutual relations, rights and responsibilities of the Parties in the course of the Register technical supervision during construction of the SPS and manufacture of materials and products for them.

The contract specifies cost of technical supervision, procedure and terms of payment. Where technical supervision is carried out based on the request, without concluding a contract, works are paid and expenses reimbursed according to the invoices made out by the Register.

5 TECHNICAL DOCUMENTATION

5.1 GENERAL

5.1.1 Construction of the SPS and manufacture of materials and products for the SPS shall be in compliance with the technical documentation approved (agreed) by the Register.

5.1.2 Prior to commencement of technical supervision of the SPS design, construction and/or operation, technical documentation shall be submitted to the Register for review in the amount sufficient to make sure that the requirements of the Rules relating to the given equipment, materials and products therefore, as well as to the quality of the rendered services specified in [9.2](#) are fully met.

5.1.3 Amendments made in the technical documentation and dealt with the components and structures covered by the requirements of the Rules shall be submitted to the Register for approval prior to their implementation.

5.1.4 The technical documentation for the SPS may be submitted to the Register in one of the following alternatives depending on the design stage:

substantiation of investments in the project of the field construction on the sea shelf;
technical design of the SPS or feasibility study (project) of the field construction on the sea shelf;

detailed design of the SPS, technological documentation and reconditioning work project;
normative and technical documents, specifications, production processes, regulations for production process and operations of the SPS;

technical documentation for standard accessories of the SPS, certificates and operating instructions.

5.1.5 Where foreign or international standards are submitted within the technical documentation for the items of the Register technical supervision, they shall be considered as a constituent part thereof, and the possibility of using them shall be confirmed in each case by approval of the technical documentation without agreeing the very standards.

In accordance with [4.1.6](#), the normative and technical documents of foreign classification societies, other national and international regulations, rules and standards may be recognized by the Register to be acceptable for application as ensuring confirmation of compliance with the requirements set in the contract specification by the customer and being consistent with the requirements of the Rules.

5.1.6 As for the rest, the general regulations for review of the technical documentation by the Register shall comply with the requirements of Section 3 of Part II "Technical Documentation" of the Rules of Technical Supervision during Construction of Ships and Manufacture of Materials and Products for Ships.

5.2 TECHNICAL DOCUMENTATION ON THE SUBSEA PRODUCTION SYSTEMS

5.2.1 The following documents shall be submitted to the Register for review and approval:

- technical documentation within the full scope of the technical and detailed design;
- specifications for materials and products;
- documentation on welding procedures and non-destructive examination of welded joints;
- documentation on application of coatings, galvanic treatment, painting, electrochemical systems of anticorrosive protection;
- program of factory tests and tests after installation of the SPS on the field, relevant test reports;
- project of marine operation for installation of the SPS (SPS component) at the production field;
- technical documentation relating to repairs (except scheduled maintenance) and modernization of the SPS.

5.2.2 The technical documentation submitted shall include documents reflecting features of a particular SPS: water area location, operating conditions, properties and parameters (pressure, temperature) of the well fluids, as well as pipeline, umbilical, etc. routes.

5.2.3 The technical documentation submitted shall include Technical Regulations for the SPS operation under all possible conditions including the emergency ones, lists of tools, instruments and spare parts, test results, technical passports, certificates for equipment, as well as information materials on floating facilities which will be used during operation of the SPS, as well as in elimination of emergency situations.

5.2.4 The documentation shall contain design information, accepted assumptions, test programs and procedures, requirements for confirmation of conformity. Tests shall be conducted for conformity of the following parameters (but are not limited to): dimensions, test and working pressure, materials, environment parameters and the requirements of these Rules and recognized standards on the basis of which the design has been developed.

5.2.5 Upon completion of construction, tests and commissioning of the SPS, final documentation shall be submitted to the Register. The amount of the final documentation and the procedure of its submission shall be specified by the Technical Regulations for the SPS operation subject to approval by the Register.

5.2.6 Subject to submission to the Register shall be technical documentation, certificates and permitting documents for the SPS, elaborated and received in accordance with the requirements of national supervisory bodies ([refer to 2.2](#)).

5.2.7 The amount of the submitted documentation on repairs and modernization of the SPS, conservation, well abandonment and SPS utilization shall be specified in each particular case.

5.2.8 The list of technical documentation on subsea pipelines and production risers shall comply with the requirements of 1.5 of Part I "Subsea Pipelines" of the SP Rules.

6 NOMENCLATURE OF ITEMS OF THE TECHNICAL SUPERVISION OF THE SUBSEA PRODUCTION SYSTEMS

6.1 The Nomenclature of Items of the Register Technical Supervision of the SPS (hereinafter referred to as "the SPS Nomenclature", [refer to Table 6.1](#)) specifies the items subject to the Register technical supervision during their manufacture at the manufacturer, installation and testing.

6.2 The materials and products of SPS manufactured and installed under the Register technical supervision shall be delivered to the manufacturer, which performs the SPS construction, with the certificates or other documents evidencing their conformity to the requirements of these Rules and/or to the standards recognized by the Register as acceptable.

6.3 Any amendments to the SPS Nomenclature may be introduced only if agreed with the Register. The materials and products not being part of the Nomenclature may be subject to survey on request from the customer.

6.4 In case of technical supervision of SPS constructed with the use of brand-new materials and accessory components, the Register has a right to unilaterally introduce amendments to the SPS Nomenclature.

Table 6.1

Nomenclature of Items of the Register Technical Supervision of the Subsea Production Systems

The Nomenclature is presented in the form of table comprising six columns.

Column 1 ("Code of item of technical supervision"): identification code of the material, product, production process or software, which consists of eight characters, is indicated.

Column 2 ("Item of technical supervision"): name of the material, product, production process or software is indicated.

Column 3 ("Group of item of technical supervision"): number of group of item of technical supervision (1 — 5) is indicated according to which the technical supervision type is assigned.

Possible schemes of technical supervision for the groups are given in Tables 5.2-1 and 5.2-2 of Part I "General Regulations for Technical Supervision" of the Rules for Technical Supervision during Construction of Ships and Manufacture of Materials and Products for Ships.

Columns 4, 5, 6 ("Installation", "Factory testing", "Functional testing"): necessity of technical supervision performed directly by the Surveyor (P) is indicated.

For the purpose of this Section:

technical supervision during installation — examination and confirmation of compliance with the Register-approved technical documentation regarding the scope and location of items of technical supervision;

factory testing during construction — testing of items of technical supervision after manufacture under test pressure and test load, as well as other tests confirming structure and reinforcement strength, quality of installation and tightness of systems and equipment;

functional testing — testing confirming functionality and serviceability of items of technical supervision. When the scopes of the functional and factory testing concur, only one testing may be conducted.

Code of the item of technical supervision	Item of technical supervision	Technical supervision of the Register			
		during manufacture of materials and products	during construction		
		Group of item of technical supervision (1 — 5)	Installation	Factory testing	Functional testing
2600000	SUBSEA PRODUCTION SYSTEMS				
2601000	ARRANGEMENTS, EQUIPMENT				
26010100	Foundations, bases and other structures to ensure fixation of the SPS				
26010101	foundations for wellhead equipment	5	P	—	P
26010102	foundation of manifolds	5	P	—	P
26010103	foundations for equipment (separators, boosters, compressors, etc.)	5	P	—	P
26010104	riser basement	5	P	—	P
26010105	templates	5	P	—	P
26010106	guide arrangements for installation	5	P	—	P
26010200	Protective structures:				
26010201	non-tight structures	5	P	—	P
26010202	tight structures designed for hydrostatic pressure	5	P	—	P
26020000	SYSTEMS AND PIPING				
26020100	Systems of well fluid gathering and treatment:				
26020101	fluid treatment system	—	P	P	P
26020102	fluid separation system	—	P	P	P
26020103	fluid injection/pumping-over system	—	P	P	P
26020104	water injection/pumping-over system	—	P	P	P
26020105	chemical reagent feed system	—	P	P	P
26020200	Drive and control systems:				
26020201	hydraulic	—	P	P	P
26020202	electric	—	P	P	P
26020203	pneumatic	—	P	P	P
26020204	combined	—	P	P	P
26020300	Wellhead equipment:				
26020301	casing head unit	3	P	P	P
26020302	tubing hanger unit (tubing head)	3	P	P	P
26020303	Christmas tree	3	P	P	P
26020304	Christmas tree cap	3	P	P	P
26020305	wellhead equipment for work performance in the well	3	P	P	P
26020306	lower riser package (drilling/workover)	3	P	P	P
26020307	X-mas tree guide frames	3	P	P	P
26020308	wellhead assembly connectors	3	P	P	P
26020400	Manifolds and manifold units:				
26020401	manifold units/manifolds	4	P	P	P
26020402	manifold pipelines	3	P	P	P
26020500	Shutoff and control valves, valve assembly:				
26020501	shutoff power driven valves	3	P	P	P
26020502	choke and control power driven valves	3	P	P	P
26020503	power driven valves for injection of chemical reagents	3	P	P	P
26020600	Hoses and umbilicals:				
26020601	subsea hoses	3	P	P	P
26020602	umbilicals with electric/hydraulic/optical fibre channels	3	P	P	P
26020603	umbilical termination heads	3	P	P	P
26020604	subsea terminations and jumpers	3	P	P	P
26020700	Components of pipelines and flowlines:				
26020701	flowline connector units	3	P	P	P
26020702	pipeline(-s) end manifold	5	P	P	P
26020703	pipeline end termination	3	P	P	P
26020704	in-line tee	3	P	P	P
26020800	Well fluid metering equipment	3	P	P	P

Code of the item of technical supervision	Item of technical supervision	Technical supervision of the Register			
		during manufacture of materials and products	during construction		
		Group of item of technical supervision (1 — 5)	Installation	Factory testing	Functional testing
26020900	Pig launching/receiving systems	—	P	—	P
26020901	Pig launchers/receivers	5	P	P	P
26050000	ELECTRICAL EQUIPMENT				
26050100	Subsea electric power supply and distribution systems:				
26050101	power supply units	4	P	P	P
26050102	uninterruptible power supplies	4	P	P	P
26050103	subsea power distribution systems	4	P	P	P
26050104	subsea transformers	4	P	P	P
26050105	subsea frequency converters	4	P	P	P
26050106	subsea cable connectors controlled by ROV	3	P	P	P
26050200	Electric drives:				
26050201	drive motors of pumps	3	P	—	P
26050202	electric drives of actuators	3	P	—	P
26050203	subsea electrical drives of compressor plants	3	P	P	P
26050204	electrical drives of process machinery	3	P	P	P
26050300	Cables and conductors:				
26050301	power cables	3	—	—	—
26050302	signal cables	3	—	—	—
26050303	optical fibre cables	3	—	—	—
26050304	cable end fitting	3	P	P	P
26050305	communication lines (conductors)	3	—	—	—
26050400	Subsea production video surveillance systems	3	P	—	P
26070000	MATERIALS				
26070100	Steel rolled products:				
26070101	for tubes and pipes and elements of pipelines	4M	—	—	—
26070102	pipes and tubes for process pipelines	4M	—	—	—
26070103	elements of process pipelines	4M	—	—	—
26070104	for protective structures, bases and foundations	4M	—	—	—
26070200	Steel semi-finished products:				
26070201	for wellhead assembly	4M	—	—	—
26070202	for fittings, connectors, terminations, etc.	4M	—	—	—
26070300	Welding consumables	2M	—	—	—
26070400	Welding process	2M	—	—	—
26090000	AUTOMATED CONTROL SYSTEMS				
26090100	Indication, Alarm, Control, Protection and Logging systems:				
26090101	hydraulic	4	P	P	P
26090102	electrical	4	P	P	P
26090103	electro-hydraulic	4	P	P	P
26090104	multiplex	4	P	P	P
26090105	autonomous	4	P	P	P
26090200	Integrated monitoring and control buoys	4	P	P	P
26090300	Systems for monitoring, control and emergency protection:				
26090301	surface	5	P	P	P
26090302	subsea for hydraulic and electro-hydraulic systems	5	P	P	P
26090303	subsea electronic	5	P	P	P
26090304	modem units and checker units	4	P	P	P
26090400	Systems for designation of SPS elements and for guidance of servicing subsea facilities and tools:				
26090401	sonar systems for designation of SPS elements and for guidance of servicing subsea facilities and tools	4	P	—	P
26090500	High integrity pressure protection system (HIPPS)	4	P	P	P

7 TECHNICAL SUPERVISION DURING MANUFACTURE OF MATERIALS AND PRODUCTS FOR THE SUBSEA PRODUCTION SYSTEMS AT THE MANUFACTURER

7.1 GENERAL

7.1.1 The provisions of this Section apply during technical supervision of materials and structural components used during construction and repair of the SPS and listed in the SPS Nomenclature ([refer to Table 6.1](#)).

7.1.2 In separate cases, at the Register discretion, technical supervision may cover the materials and products not contained in the SPS Nomenclature, which are newly developed or are components of the products listed in the SPS Nomenclature and which functionally provide the safety of the items of technical supervision. For this purpose, specimens of materials, products or new production processes after review of technical documentation by the Register shall be subject to tests according to the program agreed with the Register.

7.1.3 In addition to the requirements of this Chapter, materials and products shall meet the requirements of the relevant Sections of the Rules, as well as the requirements of the Register-approved technical documentation, specifications and other normative and technical documents adopted for the SPS project and recognized by the Register.

7.1.4 Materials and products of the SPS listed in the SPS Nomenclature and having no Certificates and other documents confirming their compliance with the Register requirements are not allowed for use during the SPS construction and operation.

7.1.5 The Register performs technical supervision at the manufacturer on the basis of the contract or request for technical supervision ([refer to 4.3](#)).

When rendering services specified in [7.4](#), [7.5](#) and [9.2](#) of this Part of the Rules by the Register and when concluding the contract, the manufacturer shall be audited for conformity with the requirements of Sections 9, 11 and 12 of Part I "General Regulations for Technical Supervision" of the Rules for Technical Supervision during Construction of Ships and Manufacture of Materials and Products for Ships.

7.1.6 Depending on the item belonging to the group of technical supervision, the compliance of materials and products with the RS requirements shall be confirmed by the following documents:

- .1 Certificate filled-in and signed by the Register (C);
- .2 Certificate filled-in and signed by an official of the firm (manufacturer) and drawn up (endorsed) by the Register (C3);
- .3 Document drawn up by the manufacturer in which the material or product compliance with the RS requirements is declared (MC);
- .4 Document drawn up by the manufacturer according to the standards of the firm (M); it shall contain data satisfactory for RS.

7.1.7 The contents of the certificates (C, C3) and the Document (MC) shall identify the material, product, their types, main parameters, as well as the manufacturer of materials and products.

Document (MC) shall at least contain:
address of the manufacture place;
name of technical documentation on an item and date of its approval by RS;
name, type or grade of the material or product;
manufacturing or serial number, lot number (as relevant);
name of the document containing data on the surveys and tests performed by the firm (manufacturer);
number, issue date and validity period of the Type Approval Certificate (CTO);

firm (manufacturer) statement of the item compliance with the approved type specified in the Type Approval Certificate (CTO);

signature of the authorized person of the firm (manufacturer).

Validity period of the certificates (C, C3) and documents (M, MC) is not specified. For the products of group 2, the contents of the Document (MC) shall be coordinated during the type approval.

7.1.8 In order to obtain the Certificate the manufacturer shall apply to the Register with a request. Technical documentation on materials and products within the scope regulated by the Register rules shall be submitted together with the request.

7.1.9 Upon review of the technical documentation, the Register sends a conclusion letter to the manufacturer. On the Register's demand, the manufacturer shall submit the testing program to the Register to be agreed upon.

7.1.10 The manufacturer shall provide all the conditions necessary for the Register to carry out technical supervision on his premises, namely:

present the technical documentation necessary to perform work, in particular, manufacturer's documentation on product quality control;

prepare the items of technical supervision for survey within the scope required;

provide for safety of surveys;

provide attendance of officials authorized to present the items of technical supervision for surveys and tests;

timely notify the Register about the time and place of surveys and tests of the items of technical supervision.

When the conditions required for performance of technical supervision are not met by the manufacturer the Register has the right to carry out surveys or to witness tests.

7.1.11 In all other respects, the general regulations on technical supervision during manufacture the SP materials and products shall meet the requirements of Section 5 of Part I "General Regulations for Technical Supervision", Section 1 of Part III "Technical Supervision During Manufacture of Materials" and Section 1 of Part IV "Technical Supervision During Manufacture of Products" of the Rules for Technical Supervision during Construction of Ships and Manufacture of Materials and Products for Ships.

7.2 APPROVAL OF TYPE MATERIALS, PRODUCTS AND MANUFACTURING PROCESSES

7.2.1 Type Approval Certificate (CTO) is a document of the Register, which certifies that a construction, properties, parameters, characteristics of a type material or product revealed in the course of surveys and indicated in the approved technical documentation, meet the RS requirements and may be used for items of technical supervision for the intended purpose.

7.2.2 The Type Approval Certificate (CTO) for a type production process certifies that an item of technical supervision manufactured according to the particular type production process and having characteristics and parameters indicated in the approved technical documentation meets the RS requirements and may be used for the intended purpose.

7.2.3 In order to obtain the Type Approval Certificate (CTO) the manufacturer shall apply to the Register with a request and submit technical documentation on the material, product or production process, as well as the program and schedule of tests. When reviewing and approving the documentation, the scope of surveys during manufacture and testing of specimens shall be specified.

7.2.4 The Type Approval Certificate (CTO) is issued by the Register for a period up to 5 years upon approval of the technical documentation and satisfactory results of surveys of the materials, products or manufacturing processes submitted. For the material or product manufactured according to the established production process, the Type Approval Certificate (CTO) is issued having regard to the data on earlier tests, production and operation experience. Account may be taken of the Type Approval Certificate of another classification society or competent body or results of the tests of a type specimen conducted with participation of the above organizations.

7.2.5 For welding consumables, the Certificate of Approval for Welding Consumables (COCM) is issued, being in the same time the document certifying recognition by the Register of the firm as a manufacturer of welding consumables in accordance with the requirements of the RS Rules.

The Certificate of Approval for Welding Consumables (COCM) is issued for a period up to 5 years subject to its annual endorsement.

7.2.6 The Welding Procedure Approval Test Certificate (COTПC) is a Register document certifying that welding procedure used at a shipyard or at a manufacturer of welded structures has been tested and approved by the Register for application.

The Welding Procedure Approval Test Certificate (COTПC) is issued for a period up to 5 years subject to its endorsement at least once every 2,5 years.

7.2.7 In other cases the type approval of materials, products and manufacturing processes shall be carried out according to Section 6 of Part I "General Regulations for Technical Supervision" of the Rules for Technical Supervision during Construction of Ships and Manufacture of Materials and Products for Ships.

7.3 RECOGNITION OF TESTING LABORATORIES

7.3.1 Testing laboratories engaged in non-destructive examination, destructive and other types of tests during manufacture, installation, repair, renovation and technical diagnosis of the SPS shall be recognized by the Register.

7.3.2 Recognition procedure for a testing laboratory is carried out on the basis of a request submitted by the testing laboratory to the Register Branch Office.

7.3.3 The Register requirements for the testing laboratories are set out in Sections 8 and 10 of Part I "General Regulations for Technical Supervision" of the Rules for Technical Supervision during Construction of Ships and Manufacture of Materials and Products for Ships.

7.3.4 Recognition of testing laboratories by the Register include:
review of documents confirming conformity of the testing laboratory with the Register requirements;
survey of testing laboratory including performance of check tests.

7.3.5 Recognition of a testing laboratory by the Register shall be confirmed by the Recognition Certificate of Testing Laboratory (СИЛ) issued in accordance with the requirements of 3.4 — 3.7 of Part I "General Regulations for Technical Supervision" of the Rules for Technical Supervision during Construction of Ships and Manufacture of Materials and Products for Ships.

7.3.6 In some cases, at the Register discretion, tests may be conducted in the testing laboratory not recognized by the Register. At that, prior to performance of tests, compliance of the testing laboratory with the requirements listed in Section 8 and requirements of 10.2.1.1, 10.2.2.1, 10.2.2.2, 10.2.4.1, 10.2.4.2, 10.2.5 and 10.2.6 of Part I "General Regulations for Technical Supervision" of the Rules for Technical Supervision during Construction of Ships and Manufacture of Materials and Products for Ships shall be verified.

7.4 RECOGNITION OF MANUFACTURERS

7.4.1 The manufacturers producing the materials and products listed in the SPS Nomenclature ([refer to Table 6.1](#)) shall be recognized by the Register on a voluntary basis. Recognition of the manufacturer implies confirmation by the Register document (Recognition Certificate for Manufacturer — СПИ) of the manufacturer capability to produce materials and products in compliance with the Register requirements.

7.4.2 Recognition of the manufacturers of the SPS materials and products shall be carried out in accordance with the provisions of Sections 8 and 11 of Part I "General Regulations for Technical Supervision" of the Rules for Technical Supervision during Construction of Ships and Manufacture of Materials and Products for Ships, provisions of 8.3 of Part I "General Regulations for Technical Supervision" of the OGE Rules.

7.5 RECOGNITION OF FIRMS (ORGANIZATIONS)

7.5.1 Firms performing the activities specified in [Table 7.5.1](#) in connection with the SPS which are subject to the Register technical supervision shall be recognized by the Register for compliance with the requirements of Sections 8 and 12 of Part I "General Regulations for Technical Supervision" of the Rules for Technical Supervision during Construction of Ships and Manufacture of Materials and Products for Ships.

Table 7.5.1

Kinds of activities of firms	
Code	Kind of activity
28001000	Construction, modernization, repair and maintenance of the SPS:
28001010	equipment and arrangements
28001020	fluid treatment system
28001030	electrical equipment
28001040	flowlines and connection pipelines
28001050	umbilicals and cables
28002000	Installation, commissioning, repair and maintenance of the SPS systems for monitoring, control and emergency protection
28003000	Theoretical training and welders' practical qualification tests during construction of the SPS (at certification centers)

7.5.2 Compliance of firms with the requirements set out in [7.5.1](#) is confirmed by the Certificate of Firm Conformity (CCП) which is issued and endorsed in accordance with the requirements of 3.4 — 3.7 of Part I "General Regulations for Technical Supervision" of the Rules for Technical Supervision during Construction of Ships and Manufacture of Materials and Products for Ships.

7.5.3 The firm shall demonstrate that its activity is performed in the area indicated in the request.

7.6 WELDING. WELDERS' CERTIFICATION

7.6.1 When performing welding operations during construction, installation and repair of the SPS the requirements of Part XIV "Welding" of the Rules for the Classification and Construction of Sea-Going Ships, Part XIII "Welding" of the MODU Rules, Part XIII "Welding" of the FOP Rules, Part XIV "Welding" of the FPU Rules and Section 5 of Part I "Subsea Pipelines" of the SP Rules shall be complied with.

7.6.2 Welding consumables used in welding during construction, installation and repair of the SPS shall be approved by the Register ([refer to 7.2.5](#)) in accordance with the requirements of Section 4 of Part XIV "Welding" of the Rules for the Classification and Construction of Sea-Going Ships.

7.6.3 Approval of the welding procedures and procedures of metal deposition used during construction, installation and repair of the SPS ([refer to 7.2.6](#)) shall comply with the requirements of Section 6 of Part XIV "Welding" of the Rules for the Classification and Construction of Sea-Going Ships.

7.6.4 Welder's Certification approved by the Register for performance of welding work during construction, installation and repair of the SPS shall be conducted according to provisions of Section 5 of Part XIV "Welding" of the Rules for the Classification and Construction of Sea-Going Ships.

8 TECHNICAL SUPERVISION OF THE SUBSEA PRODUCTION SYSTEMS DURING CONSTRUCTION

8.1 GENERAL

8.1.1 In accordance with [4.3](#), technical supervision of the SPS during construction is performed on the basis of the contract signed between the Register and the firm building of the SPS.

8.1.2 Prior to the commencement of the technical supervision during construction of the SPS the firm shall be audited by the Register for conformity with the requirements of [7.5](#). Based on the audit results, a Report with appropriate appendices shall be drawn up or a Certificate of Firm Conformity (CCП) may be issued.

8.1.3 Scope and procedure of the Register technical supervision during construction of the SPS, types of checks, tests and control are indicated in the List of Items of Technical Supervision (hereinafter referred to as "the List"). Along with the surveys performed under the List, additional periodical checks may be conducted ([refer to 8.1.5](#)).

8.1.4 The List shall be elaborated by the firm and agreed upon with the Register Branch Office which shall carry out technical supervision. The List is compiled on the basis of the SPS Nomenclature.

8.1.4.1 Referred to the items of technical supervision are also assemblage, installation processes and individual works subject to technical supervision by the Register.

8.1.4.2 Scope of surveys, numbers of drawings, diagrams, procedures and programs of tests, manufacturing processes, etc. shall be indicated in the List for each item of technical supervision.

8.1.4.3 One presentation to the Surveyor to the Register, covering one or several similar items of technical supervision or works completed in a particular production workshop or at a particular stage of the SPS installation shall be made for each item of the List. The main target of surveys under the List is checking of quality of the item of technical supervision at a particular stage of manufacture as stipulated by the manufacturing process and its admittance for further stages of equipment installation.

8.1.4.4 On agreement with the Register Branch Office, one or several documents elaborated by the firm in accordance with its existing practice, such as firm's standard on presentation of completed works, acceptance log books, etc. may be used as the List.

8.1.4.5 Surveys under the List are performed by the Surveyor upon presentation by the firm's technical control body of the item of technical supervision or completed works with the documents issued, finally verified by the firm and prepared for submission to the Register.

8.1.5 Along with the surveys performed according to the List, the Register may carry out periodical inspections not associated with the official presentation by the firm's technical control body but affecting workmanship.

8.1.6 Prior to installation of the SPS referred to the SPS Nomenclature, the surveyor to the Register shall verify that these items of technical supervision are provided with documents confirming their production under technical supervision of the Register or a classification/ supervisory body recognized by the Register.

8.1.7 The Register technical supervision during construction of the SPS in the water areas of the Russian territorial sea shelf and in the interior water areas is performed regardless of the control exercised by the RF supervisory bodies, unless otherwise specified in special agreements.

8.2 REQUIREMENTS FOR TESTING

8.2.1 General.

8.2.1.1 Technical supervision of the Register in the course of tests of the SPS aims at checking the conformity of their quality and completeness with the approved technical design, Register rules and standards.

8.2.1.2 The Register technical supervision during testing of the SPS is performed for the items of technical supervision included in the SPS Nomenclature.

8.2.1.3 The SPS is tested according to the Register- approved program which shall consider the requirements of standards and technical documents for delivery, as well as the requirements of manufacturers' programs for testing of the equipment supplied. Concurrent with the item to be tested, the technical documentation required for survey is tested. Surveys and tests of the item of technical supervision are carried out by the Register after acceptance of the item by the firm's technical control body.

8.2.1.4 The items of technical supervision which test results do not meet the requirements shall be re-tested upon elimination of causes of unsatisfactory test results. Elimination of defects and re-testing shall be agreed upon with the Register. Re-testing shall not affect further tests or interfere with their safety.

8.2.1.5 Upon completion of the tests of the SPS, the Register shall communicate its remarks to the firm, which shall be eliminated before the Register issues the documents specified in [8.3](#), as well as present a list of items to be opened up with indication of the scope of inspection.

8.2.2 Requirements for testing of the SPS equipment.

8.2.2.1 Components and assemblies of the SPS equipment shall be tested in accordance with the Register-approved test program at the stages: manufacture at works (factory acceptance tests); mounting or installation on site (integrated tests).

8.2.2.2 The Register technical supervision during acceptance tests at the manufacturer is performed for the SPS items specified in the SPS Nomenclature. The main parameters which shall be simulated on tests are performance parameters and environmental conditions encountered by the SPS at all the stages of installation and operation.

8.2.2.3 The integrated tests are recommended to be part of:
checking of the related equipment;
on-shore tests;
tests after installation on site.

8.2.2.4 Various tests to be conducted within the scope of integrated tests shall be used to confirm fulfillment of the requirements for the interfaces of the related equipment and for functioning of the completed system. The program of integrated tests shall be approved by the Register.

8.2.2.5 All components including spare parts shall be tested for ease of installation and replacement with confirmation of interchangeability. Interfaces shall be checked under static and dynamic conditions, where appropriate.

8.2.2.6 Assembling fixtures and mock-ups may be used in case when testing of the components of a real interface is unreasonable. However, it is advisable to use original equipment where it is practicable. In case of a big quantity of identical equipment, the test shall be conducted, as a minimum, on the initially produced batch.

8.2.2.7 For some SPS elements cycled tests may be required. Composition of such equipment shall be identified during designing of a particular SPS and the relevant test programs shall be approved by the Register.

8.2.2.8 When testing equipment with self-alignment properties alignment shall be deliberately disturbed in order to check the capability to self-alignment.

Where self-alignment testing is not feasible, then self-alignment shall be demonstrated through analysis.

8.2.2.9 Special tests may be needed to simulate loading/unloading and transportation processes of the SPS (SPS elements), submergence and setting-down thereof on the seabed.

8.2.2.10 The scope and procedure of SPS testing as a whole on the field depend on the SPS structure and operating conditions with consideration for the results of preceding tests of the equipment and elements of the SPS including factory acceptance tests.

In the course of integrated tests of the SPS as a whole on the field the following operations shall be carried out:

- checking of all mating components and modules for proper orientation;
- checking for tightness;
- functional tests of all electric and hydraulic control systems;
- simulation tests of system for monitoring, control and emergency protection;
- imitation of basic operations on the SPS maintenance.

8.2.2.11 The factory acceptance tests of the SPS components shall comply with the requirements of:

- [Section 5](#) of Part IX "Umbilicals" — for umbilicals;
- [Chapter 3.16](#) of Part X "Electrical Equipment" — for electric cables;
- [Section 6](#) of Part XI "Systems for Monitoring, Control and Emergency Protection" — for systems for monitoring, control and emergency protection.

8.2.2.12 Tests of subsea pipelines incorporated in the SPS are conducted in accordance with the requirements of Part I "Subsea Pipelines" of the SP Rules.

8.3 DOCUMENTS ISSUED UPON COMPLETION OF TECHNICAL SUPERVISION

8.3.1 Based on satisfactory results of all the surveys specified by the List of the items of technical supervision for the SPS, the Register Branch Office which has carried out technical supervision during construction (installation on site) and shall perform technical supervision in service shall:

draw up the Report on the SPS survey upon completion of construction;
issue the Classification Certificate for the SPS;
register the SPS with assignment of the number of registry and issuance of the number of Registry and the SPS file.

8.3.2 For the SPS with RS class it is necessary to establish the number of registry which is indicated in the Register documents issued upon completion of technical supervision during construction. The holder of the SPS number is the Register Branch Office which has carried out technical supervision during construction (installation) of the SPS.

8.3.3 Assignment of the number of registry to the SPS and registration thereof by the Register Branch Office is effected in accordance with the internal normative and technical documents of the Register.

8.3.4 Based on the satisfactory results of all the surveys specified in the List, the RS Branch Office shall draw up the Report on Survey of the SPS after construction. This Report shall show dates of the periodical surveys of the SPS concerned.

8.3.5 Based on the Report on Survey of the SPS upon completion of construction, the Register Branch Office shall draw up the Classification Certificate for the SPS.

8.3.6 Each SPS subject to the Register supervision shall have a file which shall be registered in accordance with the internal normative and technical documents of the Register.

9 TECHNICAL SUPERVISION OF THE SUBSEA PRODUCTION SYSTEMS IN SERVICE

9.1 GENERAL

9.1.1 Technical operation of the SPS possessing the Register class shall be carried out under the Register technical supervision as periodical surveys. When necessary (after accidents or incidents on the SPS) occasional surveys shall be carried out.

9.1.2 Periodical surveys are carried out by the Register to confirm/renew the SPS class. It is recommended to harmonize the SPS survey system with the Register classification surveys of the FPU/MODU/FOP from which monitoring and control of the SPS is effected and/or to which recovered well production is delivered.

9.1.3 General requirements for carrying out periodical surveys by the Register shall comply with Part I "General Provisions" of the Rules for Technical Supervision of Ships in Service.

9.1.4 The Technical Regulations for the SPS operation is developed by the designer and submitted to the Register for approval before commissioning of the SPS. It is recommended to harmonize the system of examinations and inspections prescribed by the Technical Regulations with the periodical survey system of the Register.

9.1.5 The basis for technical supervision of the SPS to be carried out by the Register is the contract made between the Register and the SPS operator.

9.1.6 All structural and technological alterations of the SPS made by the operator as a deviation from the design shall be approved by the Register. The Register shall notify of all scheduled works which are performed by the Operator on the SPS items.

9.1.7 In-water examinations shall be performed by an organization recognized by the Register to carry out in-water surveys of the SPS ([refer to 9.2](#)). The procedures of examinations and inspections of the SPS shall provide for a system of recording and documenting the results of these works.

9.2 RECOGNITION OF FIRMS — SERVICE SUPPLIERS

9.2.1 Firms that perform the activities the results of which are used by the Register in technical supervision of the SPS or are a constituent part thereof, prior to commencement of such activities, shall be audited by the Register with the aim to confirm their capability to perform similar activities.

9.2.2 Firms that perform the activities listed in [Table 9.2.2](#) shall be recognized by the Register. The recognition means confirmation by the Register document of the firm's capability to render services (perform work) in compliance with the Register requirements.

Table 9.2.2

Kinds of activities of service suppliers

Code	Kind of activity
28005000	In-water surveys of the SPS under supervision of RS surveyor:
28005001	wall thickness measurement of structures
28005002	thickness measurement of anticorrosive, insulating coatings; detection of coating damage location
28005003	measurement of cathode potential
28005004	non-destructive examination of welded joints and structures
28005005	outer in-water survey of the SPS and their sites on seabed soil

9.2.3 To be recognized by the Register, the firm shall comply with the requirements of Sections 8 and 9 of Part I "General Regulations for Technical Supervision" of the Rules of Technical Supervision during Construction of Ships and Manufacture of Materials and Products for Ships and the requirements of 1.8 of the SP Guidelines Recognition of a firm by the Register shall be confirmed by the Recognition Certificate (СП) which is issued in accordance with 3.4 — 3.7 of Part I "General Regulations for Technical Supervision" of the Rules of Technical Supervision during Construction of Ships and Manufacture of Materials and Products for Ships.

9.2.4 The requirements of the national technical supervisory bodies imposed upon the service suppliers shall be confirmed by appropriate documents no matter whether the suppliers are recognized by the Register.

9.3 SURVEY TYPES AND FREQUENCY

9.3.1 General.

9.3.1.1 In service, the SPS are subject to the following surveys:

initial;

periodical (annual, intermediate and special);

occasional.

9.3.1.2 Initial surveys are subdivided into surveys carried out during construction of the SPS under the Register technical supervision, and surveys of the SPS constructed under the supervision (or without supervision) of another classification society or supervisory body.

9.3.1.3 Special survey is carried out to renew the SPS class, as a rule, at intervals not exceeding five years of operation, provided annual surveys and one intermediate survey are carried out within this period to the extent prescribed by the Register.

9.3.1.4 Annual surveys are carried out to confirm validity of the SPS class each calendar year.

9.3.1.5 Intermediate survey is carried out to confirm the validity of the SPS class, generally, instead of the 2nd or 3rd survey, within the scope exceeding that of the annual survey.

9.3.1.6 Occasional survey is carried out after accidents, incidents, off-schedule repair of the SPS and in other necessary cases.

9.3.2 Initial surveys.

9.3.2.1 Initial survey is carried out to confirm the compliance of the SPS with the requirements of the Rules and to assign class to the SPS which is submitted to the Register for the first time.

Also submitted to initial survey is the SPS, which previously had the Register class but lost it due to some reasons (withdrawal of class) or which underwent modernization with extension of the application area that required change in the SPS class notation.

Initial survey consists of thorough examination, checks, tests and measurements, which extent is each time determined by the Register depending on the environmental conditions and service period, procedures used in the production and offloading systems, the technical condition of equipment, etc.

9.3.2.2 The SPS constructed and installed not in compliance with the Register rules, without supervision of the Register, other classification or supervisory body may be submitted to initial survey.

In this case, initial survey, which scope is established by the Register, implies thorough and overall survey accompanied, where necessary, by testing of the SPS and its components to confirm their full compliance with the requirements of the Register.

9.3.2.3 Where the SPS and the relevant technical documentation are provided with certificates or permits issued by another classification society or supervisory body, initial survey may be carried out within the scope of a special survey.

Where the necessary technical documentation, certificate or permit for any component of the SPS is unavailable, the scope of the Register surveys for such equipment may be increased.

9.3.3 Annual surveys.

9.3.3.1 Annual surveys of the SPS carried out to confirm validity of the class is aimed at establishing that the technical condition of the SPS meets sufficiently the conditions of maintaining the class, and also at checking the operation of individual machinery, arrangements and installations covered by the requirements of the Rules.

9.3.3.2 The scope of annual surveys is specified by the Register. Annual surveys may be carried out, as a rule, within 3 months from the appointed date of a special survey.

9.3.4 Special surveys.

9.3.4.1 Special surveys carried out for renewal of the validity of the SPS class are aimed at establishing that the technical condition of the SPS, changes in its composition and design comply with the requirements of the Rules.

9.3.4.2 Special surveys, which scope is specified by the Rules, are carried out at intervals set by the Register, generally, at five-year intervals, with renewal of the validity of the SPS class for the following five years.

9.3.4.3 Necessary examinations, measurements, checks in operation and other actions to confirm the compliance of the SPS with the requirements of the Rules shall be carried out within a period between special surveys and immediately during the special survey.

9.3.4.4 The dates of special surveys of the SPS are determined starting from the date of initial survey, date of construction, date of changes in class notation or date of assignment of class to the SPS constructed without the Register supervision.

9.3.5 Intermediate surveys.

Intermediate survey of the SPS is carried out between special surveys at the dates agreed with the Register. The scope of intermediate survey is specified by the Register.

9.3.6 Occasional surveys.

9.3.6.1 Occasional surveys of the SPS are carried out in all other cases, except for the initial and periodical surveys. The scope and procedure of surveys are specified by the Register proceeding from the purpose of the survey, service period and technical condition of the SPS.

9.3.6.2 Occasional surveys are carried out to reinstate the validity of the SPS class after its suspension, to check the elimination of identified defects and damages, after accidents, at significant replacement of equipment, renovation and repairs not concurring in terms with periodical surveys.

9.3.6.3 Occasional surveys of the SPS or individual elements thereof are carried out after incidents which may affect the structural integrity of the SPS or individual elements thereof including cases when the structures or equipment make recorded or assumed contacts with foreign objects (anchors, trawls, ice, etc.), as well as the cases when environmental parameters exceed parameters adopted in design of the SPS in order to determine the maximum allowable loads due to environmental effect.

Occasional survey after accident is carried out to identify the type and nature of damage, its cause, to determine the extent of work for elimination of the accident consequences, as well as the possibility and conditions of maintaining the SPS class.

9.3.7 Scopes of periodical surveys.

9.3.7.1 The scope of periodical surveys is specified by the Register based on the structural features of a particular SPS, its maintenance scheme and results of preceding surveys.

9.3.7.2 The basis for periodical surveys is information on maintenance, examinations, tests and repairs of the SPS or its individual elements carried out by the operator in accordance with the Technical Regulations for the SPS operation approved by the Register.

9.3.7.3 In the process of operation performed by the SPS operator, control shall be exercised over the parameters describing the condition of all functional, back-up and emergency systems of the SPS, including the data received during the external in-water survey (refer to [Section 10](#)).

The scope and frequency of maintenance, examinations and tests performed by the SPS operator shall take into account:

- results of retrospective analysis of consequences of incidents and failures;
- analysis of data of process parameters monitoring systems;
- data on changes of corrosion and erosion properties of recovered well fluids;
- change in electrochemical protection properties, resulting in an increase of external corrosion rate;

fatigue failure due to vibration;
change in the design position due to geotechnical processes affecting the condition of foundation soils of SPS items;
development of processes affecting the ability to perform operations on the shut-off and control valves using ROVs or deterioration of the ability to identify them (development of biological fouling, formation of solid deposits, sedimentation);
environmental effects, including maintenance and repair loads;
exhibition of hidden manufacturing defects;
failures caused by construction and installation errors;
formation of various blockage.

The scope and procedure for conducting external in-water surveys are carried out in accordance with provisions of [Section 10](#).

9.3.7.4 Not later than 2 months before the date of special or annual survey, the operator shall submit to the Register the Report on SPS safety prepared on the basis of analysis of the SPS maintenance and inspection performed by the operator with the assistance of recognized firms ([refer to 9.2](#)). All the information on the SPS operation shall be kept by the SPS operator and made available upon the Register's request.

9.3.7.5 Where the Register considers the information presented as insufficient for confirmation of the SPS safely, the operator shall ensure performance of an additional inspection with the participation of the Register.

9.3.7.6 Upon the SPS operator's request, the system of periodical surveys may be supplemented with a system of continuous survey of the SPS or individual elements thereof.

9.3.8 Documents issued by the Register upon completion of surveys.

9.3.8.1 Upon completion of annual/intermediate/ special survey of the SPS, the Register shall issue a Report which confirms the validity of the SPS class for the next annual period, provided the survey results are satisfactory, and if the results of special survey are satisfactory, the Register renews the validity of the SPS class, making a relevant entry in the Classification Certificate being in force (annually confirmed) till the next special survey.

9.3.8.2 If the results of initial survey of the SPS are satisfactory, the Register shall issue a Report, Classification Certificate and other documents specified in [8.3](#).

10 EXTERNAL IN-WATER SURVEY

10.1 External in-water survey in service is carried out to determine the technical condition of subsea SPS items, as well as to determine the condition of adjacent areas of the seabed and water area.

The provisions of this Chapter are also applicable at the stages of construction, repair, technical upgrading, modernization, overhaul, reconstruction.

Information about the current technical condition of SPS items, the condition of adjacent seabed and water areas is intended for subsequent analysis to assess performance, serviceability, prediction of changes, and develop recommendations for the further reliable and safe operation of subsea production systems.

Normally, subsea surveys are carried out without technological process shutdown of subsea production systems.

In addition to the requirements of this Chapter, the applicable provisions of 4.1.2.2 of the SP Guidelines, especially related to linear facilities, shall be met.

10.2 External in-water survey of SPS items shall be aimed at:

- detection of any exposure at items locations (anchoring tracks, use of fishing gear, wave effects and currents, ice gouging, seabed soil drift/erosion, etc.);

- detection of external defects of SPS items including explicit damages to integrity of elements or its coatings and/or their consequences (leakage of fluids);

- monitoring of hydrological characteristics (water temperature, current velocities and directions, bathymetry, etc.);

- assessment of surface condition of item elements and interfaces of subsea equipment subject to biological fouling;

- inspection of foundation structures of items;

- check of horizontal location and elevation of items (coordinates, course, heel, trim) for technical documentation conformity;

- check of geometrical parameters of items' structural elements for technical documentation conformity, for determination of parameters of defects, damages, shape deviations (including erosion, wear, deflection, heels, etc.);

- check of condition of anticorrosive coatings;

- check of condition of electrochemical protection of items (including measurement of cathodic potential);

- check of condition of identification marking and painting of items/elements;

- check of corrosion wear of item elements (including residual thickness measurement of walls);

- inspection of connectors of item elements for leakages, damages and deviations from technical documentation;

- measurement of physical and mechanical properties of materials by non-destructive testing methods;

- sampling of soil, water, materials to determine actual properties (when it is necessary).

- photographing and video filming of items;

- drawing up of the report on items conditions and data archiving.

10.3 The external in-water survey of SPS items shall be carried out in compliance with the requirements of performance specification for the work, requirements of SPS technical operation according to the procedure and program of the SPS operator and approved by the Register.

It is recommended to harmonize the SPS operator's examinations and inspections with the RS periodical surveys.

10.4 Specialized organizations recognized by the Register (refer to [9.2](#)) that carry out engineering surveys on the continental shelf in compliance with the requirements of national supervisory authorities and have satisfactory experience in conducting underwater engineering works and diagnostic surveys of subsea facilities shall be involved in performing external in-water surveys.

10.5 The main methods of conducting external in-water surveys of SPS items are the visual, hydroacoustic and instrumental surveys.

10.5.1 Visual survey methods involve the use of ROV, AUV or involvement of divers with underwater photography equipment for photo and video recording and equipment/tools necessary for contactless/contact antifouling cleaning of SPS items.

10.5.2 Hydroacoustic survey methods involve the use of special purpose equipment (multibeam echo sounder, side-scan/scanning sonar, underwater hydroacoustic/optical scanner, etc.). Hydroacoustic survey methods are applicable for obtaining and documenting three-dimensional (two-dimensional) coordinates of position of SPS items and adjacent seabed areas.

10.5.3 Instrumental survey methods involve the use of ROV, AUV or involvement of divers with sets of instruments (ruler, feeler gauge, inclinometer, sounding rod, plumb, underwater ultrasonic thickness gauge, cathode potential meter, etc.) and equipment/tools necessary for contactless/contact antifouling cleaning of SPS items. Instruments intended to monitor the technical condition of SPS items and adjacent areas of the seabed, as well as instruments used for correcting measured values, shall be verified and calibrated.

Instrumental methods are applicable for obtaining and documenting quantitative indicators of defects, damages, and shape deviations.

10.6 Upon agreement with the Register, the inspection methods may be specified, detailed and combined by a specialized organization performing the survey.

10.7 Before commencing the external in-water survey, the following documents shall be submitted to the Register for review:

- survey procedure and program;
- technical documentation for SPS items subject to survey (list and scope of documentation shall be sufficient for preparation and execution of work);
- data of geological engineering survey in the area of SPS installation;
- data of previous surveys results, including information about failures or damages to specific equipment or its components;
- documentation on performed repairs and reconstruction of items.

10.8 Survey procedure and program shall include the following main elements:

- general layout plan (location map) of the item;
- brief functional and technological characteristics of the item;
- navigational and hydrographic characteristics and ice regime of the item area;
- purpose and tasks of survey;
- boundaries of survey;
- list of input data;
- list, types and scope of scheduled works;
- survey methods;
- specifications and the purpose of applied devices, equipment (including equipment for underwater photo and video recording), tools, instruments, software systems;
- data on metrological calibration, qualification of instruments, certification of software systems;
- particulars of the ships (special-purpose craft) used during survey;
- justification for usage of non-standard technologies and methods of survey (if any);
- organization chart of survey;
- requirements for conditions of work execution (wind velocity, wave height, current velocity, ice conditions, environmental limitations, etc.);

- survey schedule;
- measures to comply with the requirements for accuracy and availability of data and characteristics obtained as a result of surveys;
- measures to ensure safe working conditions;
- measures for environment protection measures;
- organization of field works, including provision of floating equipment and communication;
- list, forms and number of reports on survey results (including forms of work completion certificates, diagrams and lists of defects, damages, shape deviations, seabed topography change, presence of foreign objects, etc.);
- text and graphic appendices necessary for survey execution including work scope justifications.

10.9 When any damage (defects) of SPS structures and equipment affecting the normal operation are detected by divers or ROV operators during visual inspection, this information shall be reported to the Register as soon as possible.

10.10 Proceeding from the results of external in-water survey, the reports shall be submitted to the Register. The reports shall be issued in compliance with the performance specification, requirements of SPS technical operation regulations, national and/or international standards and standards of the SPS owner/operator.

PART II. GENERAL REQUIREMENTS FOR DESIGN OF THE SUBSEA PRODUCTION SYSTEMS

1 GENERAL SAFETY PRINCIPLES

1.1 LAYOUT OF THE SUBSEA PRODUCTION SYSTEM AND ITS COMPONENTS

1.1.1 The layout of the subsea production system shall ensure accessibility for safe operation, maintenance, repair, conservation and utilization and, where possible, fully preclude or minimize environmental effects (seismic effects, current, waves, ice, etc.) and effects of accidental loads (heavy shipping and fishing, etc.) on the SPS components.

1.1.2 During design of the SPS it is necessary to ensure maximum possible unification of individual parts, assemblies and systems of the subsea wellhead equipment, provided their functional purpose is identical.

1.1.3 Position of the SPS shall be determined on the basis of the results of comprehensive investigations including bathymetric survey, geological engineering survey and measurements of hydrological parameters.

1.1.4 Routes of the subsea field pipelines, flowlines, cables and umbilicals shall be such as to ensure their minimum extent. Crossings of the field pipelines and cables shall be avoided.

1.1.5 Mutual arrangements of the SPS components shall provide for ease of maintenance with the use of specified technical facilities (diving equipment, subsea equipment), possibility of performing assembling/disassembling operations during repairs, modernization and utilization.

1.1.6 Provision shall be made in the design for the possibility of maintaining and repairing individual components of the SPS without interrupting operation of other components and functioning of the SPS as a whole. A possibility shall be provided during design for carrying out nondestructive examination.

1.1.7 The layout of the SPS equipment shall, where possible, ensure ease of access to each component thereof for in-service attendance, as well as ease of disassembling it.

1.1.8 Rotating units, electrical equipment, valves shall be arranged in such a way that shall minimize danger in case when the SPS is serviced by divers.

1.1.9 The SPS and its separately arranged components shall be identified by sonar responder beacons. The number, position and working frequencies of the responder beacons are determined to fit a particular SPS and shall be specified in the technical documentation approved by the Register.

1.1.10 Regular electrical power for the sonar responder beacons shall be supplied from the electric system of the SPS or from an autonomous power source designed for use during at least 1 year.

When using regular power supply from the electric system of the SPS, each sonar responder beacon shall be provided with an autonomous power source turned on automatically in case where regular power supply of the SPS is cut off.

1.1.11 Where the SPS (SPS components) incorporate tight compartments (tight protective structures) visited by personnel to carry out precautionary and repair work, the SPS (SPS components) shall be equipped with an emergency sonar beacon with fixed frequency of 37,5 kHz meeting the requirements of the MS/DS Rules.

1.2 MATERIALS

1.2.1 General requirements.

1.2.1.1 Materials for the SPS shall be selected with due consideration regarding the characteristics of environment, well fluids, working media (water injected into the bed, chemical reagents, inhibitors, working media in the hydraulic systems, etc.), mechanical properties and corrosive resistance of materials, design period of use and repairability.

1.2.1.2 It is recommended that the materials for the SPS be selected in accordance with the requirements of the present Chapter and standards recognized by the Register, in particular, Section 6 of ISO standard 13628-1.

1.2.1.3 All materials used for the SPS shall be approved by the Register.

Subject to special consideration by the Register, delivery of materials and products in compliance with the national and international standards recognized by the Register may be permitted.

1.2.1.4 Firms manufacturing materials and products for the SPS shall be recognized by the Register in accordance with 7.4 of Part I "General Regulations for Technical Supervision". To confirm properties of the materials used, the Register may require additional tests to be conducted.

1.2.1.5 Selection of structural materials for manufacture of manned (visited) compartments designed for use under hydrostatic pressure of the environment, including hyperbaric compartments, as well as welding of such compartments shall be made in compliance with the requirements of the MS/DS Rules.

1.2.1.6 For the equipment and structures arranged in compartments with air or other dry atmosphere, use of combustible materials shall not be allowed.

Particular attention shall be given to selection of materials to be used for the manufacture of the SPS structures and equipment which may need repair in operation with the use of cutting and welding under hyperbaric conditions.

1.2.1.7 When selecting materials for particular structures the possibility of carrying out preventive inspections and repairs shall be taken into account.

1.2.1.8 For all contacting units and neighbouring different metals a corrosivity evaluation shall be made.

1.2.1.9 General provisions defining the scope and procedure of technical supervision of the materials are set forth in Section 5 of Part I "General Regulations for Technical Supervision" of the Rules for Technical Supervision during Construction of Ships and Manufacture of Materials and Products for Ships and in Section 1 of Part XIII "Materials" of the Rules for the Classification and Construction of Sea-Going Ships.

1.2.2 Requirements for metallic materials.

1.2.2.1 The requirements for metallic materials apply to carbon, low-alloyed and corrosion-resistant (stainless) steels used for the manufacture of the SPS.

1.2.2.2 Metallic materials for the subsea wellhead equipment, manifolds, assembly of the system for gathering of well fluids shall be specified proceeding from the accepted level of technical requirements in accordance with ISO 13628-4 which considers the values of working pressure and temperature, operating conditions, presence and concentration of hydrogen sulphide and other corrosive substances in the well fluids.

1.2.2.3 Metallic materials resistant to sulphide stress cracking and to hydrogen induced/step-by-step cracking shall be used at the values of partial/absolute pressure of hydrogen sulphide or volume concentration of hydrogen sulphide cited in 1.3 of Part V "Systems and Piping" of the OGE Rules.

1.2.2.4 Materials used for the manufacture of subsea pipelines including flowlines and discharge lines shall meet the requirements of 4.1 — 4.5 of Part I "Subsea Pipelines" of the SP Rules and of 2.2 — 2.4 of the SP Guidelines.

1.2.2.5 Steels used for structures and equipment of the SPS shall be delivered according to specifications and standards agreed with the Register and containing requirements for:

- chemical composition;
- melting procedure;
- tests to confirm mechanical properties;
- heat treatment conditions;
- non-destructive examination and acceptance criteria;
- deforming techniques.

1.2.2.6 Metallic materials used in flexible polymer-metal pipes for subsea pipelines (flowlines) and umbilicals shall meet the requirements of 4.6.3 of Part I "Subsea Pipelines" of the SP Rules and 2.6.4 of the SP Guidelines.

1.2.3 Polymeric materials.

1.2.3.1 The requirements apply to polymeric materials used for the manufacture of umbilicals, cables and flexible polymer-metal pipes (flowlines) and injection lines).

1.2.3.2 Selection of polymeric materials, including elastomers, shall be based on a thorough assessment of the functional requirements for products in which they are used, with due consideration for the particular conditions of use and design service life.

1.2.3.3 The quality of polymeric materials used at the manufacturer for producing products and equipment for the SPS shall be subject to tests within the scope agreed with the Register.

1.2.3.4 Specimens for tests used to determine mechanical, physical and other characteristics of polymers used in the SPS structure shall be cut out from the materials manufactured under the technological manufacturing conditions. If the polymer contains a plasticizer, the tests shall be conducted for both the plasticized and the non-plasticized materials.

1.2.3.5 The polymeric materials shall be tested in accordance with the requirements of the standards accepted by the Register, as permissible for use. The requirements for the polymeric materials used for manufacture of flexible polymer-metal pipes shall meet the requirements of 4.6.2 of Part I "Subsea Pipelines" of the SP Rules and 2.6.3 of the SP Guidelines.

1.3 CORROSION PROTECTION

1.3.1 Arrangements shall be made to protect structures and equipment of the SPS against corrosive wear. Special precautions shall be taken to protect structures and equipment in areas where accessibility for inspection and maintenance is limited.

Corrosion protection shall be provided with the use of special coatings, sacrificial anodes and cathodic protection.

Corrosion protection scheme for the components of a particular SPS shall be agreed with the Register.

1.3.2 Protective coatings shall be designed for the entire lifetime of the SPS.

Coatings applied onto the surfaces of structures and equipment in contact with seawater shall prevent or minimize marine growth.

1.3.3 The scheduled dates for replacement of the sacrificial anodes and process charts of engineering underwater works on replacement of the sacrificial anodes shall be determined at the SPS design stage and approved by the Register.

The scheduled dates for replacement of the sacrificial anodes may be revised based on the results of the routine inspections of the SPS components in service.

1.3.4 Process charts for restoration of the cathodic protection system in case of failure thereof shall be determined at the SPS design stage.

1.3.5 Pipelines being part of the SPS shall be protected against corrosion in compliance with the requirements of Section 7 of Part I "Subsea Pipelines" of the SP Rules.

1.3.6 The requirements for the cathodic protection and sacrificial anode system of the SPS shall comply with 7.4 of Part I "Subsea Pipelines" of the SP Rules, as far as applicable.

1.3.7 The following structural materials of SPS shall be additionally checked for their susceptibility to hydrogen embrittlement under the action of cathodic protection in sea water:
martensitic stainless steels and high-alloy steels with a yield strength of more than 900 MPa;
hardened low-alloy steels, with a hardness value higher than 35 HRC;
nickel-based precipitation-hardened alloys;
high-strength titanium alloys.

1.4 PHYSICAL PROTECTION

1.4.1 All components of the SPS shall be protected against accidental damage (caused by ice, fishing gear, anchors, falling objects, etc.) by special structures.

1.4.2 The requirements for the protective structures are set out in [Part V](#) "Protective Structures".

1.5 SAFETY PROVISIONS

1.5.1 SPS shall be designed to ensure that no single failure will cause an unacceptable risk to personnel safety and the environment. The main objective shall be to design a system in which no single failure will not result in total shut down of the system or will not prevent the safety of the well.

1.5.2 SPS shall be designed so that any system failure or damage of components that influence the ability to perform operations or control functions, shall provide automatic adjustment of the system to a safe state. This applies to (electrical, hydraulic, pneumatic) power supply failure or control system failure, or the complete failure of the system parts.

2 MARKING

2.1 The colours of the subsea equipment components and their lighting shall provide clear visibility when inspected with the use of underwater video systems and/ or diver intervention.

Colours and marking of the subsea equipment components shall comply with the requirements of Annex B to ISO 13628-1.

2.2 All major structural members of the SPS shall be marked in order to enable identification during under-water inspections and works with the use of diver and/or ROV intervention.

2.3 Supervisory and control equipment, terminals, cable ends, pipe ends, valves, as well as peculiar reference points (e.g. points where the residual thickness of metal shall be regularly measured, etc.) shall be separately marked.

2.4 Actuators of the shutoff and regulating valves shall be equipped with position indicators of the valves.

2.5 Methods used for marking shall ensure unambiguous interpretation.

Marks not associated with the maintenance of the SPS in service (fitted in the process of manufacture and installation) shall be removed.

2.6 Methods used for fitting identification marks shall be such as to ensure visibility of the marks throughout the lifetime of the SPS.

In case where damage of the marks is detected, they shall be restored without delay.

3 PROTECTIVE BARRIER SYSTEM

3.1 The methodology for determining protective barrier system configurations shall be developed at the earlier stages of design and shall be based on the safety assessment for the SPS (refer to [Part XIII](#) "Safety Assessment") to be made in the course of design. In so doing, it is necessary to define what types and how many barriers are required for operation of the facilities through all of the various phases of the SPS life, including the following:

- installation activities, including tie-in of subsequent wells to a live manifold;
- hook-up and commissioning activities;
- routine production and maintenance operations, including service modes such as circulating of discharge lines;
- pig and diagnosis facility launcher/receiver;
- drilling tool re-entry;
- replacement of a wellhead assembly;
- planned repairs;
- decommissioning activities.

3.2 Passive, active and temporary barriers may be used for the SPS.

3.2.1 The permanent passive barriers shall include:

- cement plug/dense deposits of destructed rock;
- downhole packers;
- subsea wellheads;
- downhole components (gas-lift valves, mandrels, valves for chemical injection);
- casing and tubing strings;
- bodies and piping of subsea wellhead assembly, manifolds, valve blocks;
- pipeline systems, including jumpers, connector bodies;
- pressure-sealing caps.

3.2.2 The active barriers designed to be routinely activated when in operation include:

- downhole SCSSVs;
- X-mas assembly valves including valves in the production and annulus flow paths, as well as valves in hydraulic and chemical injection lines;
- manifold valves including hydraulically operated valves;
- flowline isolation valves and valves at the top of a riser, check valves, including valves in downhole gas-lift and in chemical injection lines.

3.2.3 The temporary barriers are designed to contain pressure for a limited time period and include:

- kill weight mud of increased density;
- downhole tubing plugs which do not remain in the well;
- well control package;
- BOP assembly.

3.3 During production activities, at least two independent barriers shall be available to prevent leak of well fluids to the environment. No failure of a single barrier, no matter what is the cause thereof, shall lead to loss of sealing and loss of well control.

3.4 Producing and service wells with subsea completion and infield pipelines shall be equipped with a system of valves fitted in series to shut in each well and shut down each pipeline.

The minimum number of valves and the types of actuators shall be established by the aid of the failure effect analysis ([refer to Part XIII](#) "Safety Assessment").

3.5 The manually operated valves shall have marking, which clearly and unambiguously advise movement to open or movement to closed position.

3.6 Reliability of the accepted system of well shutting-in and killing shall be documented by the failure effect analysis ([refer to Part XIII](#) "Safety Assessment").

PART III. OPERATIONAL CONDITIONS AND DESIGN LOADS

1 OPERATIONAL CONDITIONS

1.1 ENVIRONMENTAL CONDITIONS

1.1.1 All environmental phenomena which loads affect operational reliability and safety of the SPS as a whole or of individual components thereof (hydrostatic pressure, waves, currents, ice, seismic effects, biological activities, etc.) shall be considered in the SPS design.

1.1.2 All possible loads which can have an effect on the SPS components at the manufacture, transportation and construction (mounting/dismounting) stages.

1.1.3 Environmental parameters (wind, waves, environmental temperature, etc.) shall be accepted on the basis of the results of engineering surveys which shall be carried out in the area wherein the SPS is installed at the stage preceding development of the engineering design of the SPS.

The environmental parameters shall be defined on the basis of processing of statistical data (results of long-term measurements) according to regulations and standards in force.

1.2 PROPERTIES OF WELL FLUIDS AND PROCESS AND WORKING LIQUIDS

1.2.1 Physical and chemical composition of the well fluids and process liquids, possible and limiting values of flow velocities, pressure and temperature, as well as concentrations of corrosive components in all components of liquid and gas systems being part of the SPS shall be defined at the SPS design stage.

Content of the following substances shall be specified especially for:

hydrogen sulphide (H₂S) and other sulphur compounds;

water and water soluble salts;

oxygen (O₂);

carbon dioxide (CO₂);

sand;

paraffins;

hydrates.

As applied to a particular field, it is necessary to determine: likely presence and maximum permissible concentrations in the process liquids of other chemical substances which may affect properties of the materials used (cause corrosion of metals, deterioration of sealing polymeric materials, etc).

1.2.2 To be determined in the design are parameters of the SPS systems and arrangements during storage, installation, pressure tests and performance checks, as well as the resistance to environmental effects of seawater, moist air and the necessity of using corrosion inhibitors.

1.2.3 It is essential to work out requirements for the quality and cleanliness of the working liquids in hydraulic systems of actuating mechanisms.

2 DESIGN LOADS

2.1 ENVIRONMENTAL LOADS

2.1.1 General.

2.1.1.1 Design loads acting on the SPS shall account for the operational conditions (external loads and functional loads), test loads and loads during transportation and construction (mounting/dismounting). For each type of loads which are determined in accordance with [2.1](#) and [2.3](#), the design value of the load shall be multiplied by significance factor γ determined, as specified in 2.1 of Part I "Subsea Pipelines" of the SP Rules.

2.1.2 Water level variations.

2.1.2.1 For designing of the SPS, due consideration shall be given to likely variations of sea level in the area wherein the SPS is installed, provoked by astronomical tidal phenomena, piling-up and seasonal river flow (when the SPS is installed near estuaries of big rivers).

Variations of sea level shall be considered when:

- determining hydrostatic pressures on the SPS components;
- designing the SPS components connected with water surface (risers, umbilicals, etc.);
- determining installation depth of the SPS components with consideration for ice formations (ice field, icebergs, hummocks, grounded hummocks);
- determining installation depth of the SPS components with consideration for the draught of the ships than serve them;
- planning and executing operations for transportation and mounting (dismounting) of the SPS components;
- planning and executing operations for maintenance and repair of the SPS.

2.1.2.2 The design values of hydrostatic pressures shall be determined in accordance with Formula (3.3.5-4) of Part I "Subsea Pipelines" of the SP Rules.

2.1.3 Wave loads.

2.1.3.1 For designing of the SPS due account shall be given to wave parameters in the area wherein it is installed.

Depending on the depth at which the SPS components are positioned, influence of waves may manifest itself both as the direct action of horizontal and lifting forces and as other phenomena leading to instability of the SPS on the seabed. Account shall be also given to likely liquefaction and displacement of the seabed due to wave action.

2.1.3.2 For determination of loads induced by wave action on the SPS components, account shall be given to possible influence of closely-spaced adjacent structures of the SPS on the change in the wave particles velocities and accelerations.

2.1.3.3 For designing of the SPS wave loads shall be determined with the use of a procedure agreed with the Register with consideration for the installation depth and structural features of the SPS.

For structures of intricate shape, the wave loads which cannot be analytically determined with sufficient accuracy, these shall be determined using simulation tests.

2.1.3.4 Influence of waves and wind may be also taken into account when planning and executing operations for transportation and mounting (dismounting) of the SPS components, as well as for maintenance and repair of the SPS.

2.1.3.5 The design values of the wave particles velocities and accelerations shall be determined in accordance with the requirements of 2.6 of Part I "Subsea Pipelines" and Appendix 5 of the SP Rules.

2.1.4 Undercurrent loads.

2.1.4.1 For designing of the SPS consideration shall be given to the parameters of currents of any nature in the area wherein the SPS is installed.

2.1.4.2 Where the SPS is located in water areas with seabed being prone to destruction due to scouring, special investigations of the flow conditions in the vicinity of the seabed are required.

2.1.4.3 For designing of the SPS, the current loads (including variable hydrodynamic loads) shall be determined with the use of a procedure agreed with the Register with consideration for the installation depth and structural features of the SPS (refer to 2.5 of Part I "Subsea Pipelines" SP Rules).

For structures of intricate shape, the current loads which cannot be analytically determined with sufficient accuracy, these shall be determined using simulation tests.

2.1.4.4 Influence of currents shall be accounted for during planning and executing operations for transportation and mounting (dismounting) of the SPS components, as well as operations for maintenance and repair of the SPS.

2.1.5 Ice effect.

2.1.5.1 When the SPS is located in water areas where ice may develop or drift, consideration shall be given to possible effect of ice field, hummocks, icebergs on the SPS and adjacent seabed with the use of a procedure agreed with the Register.

2.1.5.2 Ice effect shall be accounted for planning and executing operations for transportation and mounting (dismounting) of the SPS components, as well as operations for maintenance and repair of the SPS.

2.1.5.3 The possibility of ice acting directly on the SPS components shall be eliminated through installation of special protective structures designed to resist loads induced by drifting ice fields, icebergs, hummocks, grounded hummocks. Other protection methods may be applied instead of protective structures if agreed with the Register.

2.1.5.4 When the SPS is installed in freezing water areas which feature intense ice gouging of seabed by ice formations, the SPS components shall be buried into the seabed soil to a depth exceeding the possible ice gouging depth according to the requirements of 8.3 of Part I "Subsea Pipelines" of the SP Rules.

2.1.6 Environmental temperature.

2.1.6.1 For designing of the SPS, it is essential to identify the possible minimum and maximum seawater temperature in the area where the SPS is located with the aim to substantiate proper selection of the materials.

2.1.6.2 When planning and executing operations for transportation and mounting (dismounting) the SP components it is essential to determine the possible subzero air temperature with the aim to account for the potential icing-up.

2.1.7 Seismic loads and seabed soil characteristics.

2.1.7.1 For designing of the SPS, seismic, geological and geotechnical conditions in the area of the SP installation shall be considered, and it is necessary to determine seismic loads acting on the SPS using the procedure agreed with the Register and in accordance with the requirements of 3.1.2.4 of Part II "Hull" of the FOP Rules and 2.12 of Part I "Subsea Pipelines" of the SP Rules, to the extent as applicable.

2.1.7.2 Load-carrying capacity of the seabed shall be determined on the basis of the results of the geological engineering survey in the area of the SPS installation carried out according to the requirements of the regulations and standards in force.

2.1.7.3 When selecting the SPS position, consideration shall be given to the accumulations of gas, gas hydrates in the seabed soil. Installation of the SPS in locations where near-bottom gases are likely to seep or gas hydrates accumulate is prohibited.

2.1.8 Corrosion effect.

2.1.8.1 For designing of corrosion protection system for the SPS components, the following properties of seawater and soil representative for the actual location, with their seasonal variations shall be considered in total:

temperature;

salinity;

oxygen content;
pH value;
electric conductance;
biological activity (sulphate reducing bacteria).

2.1.9 Marine growth effect (fouling).

2.1.9.1 For designing of the SPS, the effect of marine growth on the SPS components shall be considered, taking into account all biological and environmental factors relevant to the site in question.

2.1.9.2 For determination of the hydrodynamic loads on the SPS components special attention shall be paid to the increase of the structure dimensions and the change in the surface roughness of the structures when marine growth accumulates.

2.1.9.3 In cases where the accumulated marine growth can lead to decrease in the safety level of the individual SPS components or the SPS as a whole, arrangements shall be provided within the context of in-service attendance to prevent marine growth and to timely clear the structures and equipment from accumulated marine growth.

The allowable fouling parameters, arrangements to prevent fouling and frequency of making arrangements to clear the structures and equipment from fouling are subject to determination in each particular case.

2.1.9.4 When performing repair and dismounting work on the SPS, the change in the mass and buoyancy of the structures and equipment due to marine growth shall be considered.

2.1.10 Accidental loads.

2.1.10.1 Among the accidental loads acting on the SPS which shall be taken into account in designing, are loads induced due to direct or indirect action, including, not only, the following:

- dropped objects;
- impact against trawling board;
- catching by anchor and break of anchor cable;
- fire and explosion;
- damage to and unpremeditated flooding of a compartment;
- error in dynamic positioning of the laying vessel;
- external excessive pressure;
- internal excessive pressure;
- fault of turntable driving gear (refer to 4.8 of Part III "Arrangements, Equipment and Outfit" of the FPU Rules).

2.1.10.2 Components and values of the accidental loads applied to the SPS components shall be stipulated in the design specification and approved by the Register. The consequences of the accidental load effects shall be analyzed on the basis of the SPS safety assessment ([refer to Part XIII "Safety Assessment"](#)).

2.1.10.3 In fishing areas, loads due to effects of bottom trawls, purse seines and other fishing gear are likely to occur. In these areas, the possibility of the fishing gear affecting directly the SPS components shall be eliminated through installation of special protective structures designed to resist the relevant loads.

2.1.10.4 When determining loads from the dropped objects, the possibility of dropping from the supply vessel of particular tools and appliances used for maintenance and repair of the SPS concerned shall be considered.

2.1.10.5 When determining loads from anchor catching, the possibility of catching the SPS components by the anchors of vessels and craft of particular types shall be considered.

2.2 LOADS DURING TRANSPORTATION AND INSTALLATION ACTIVITIES

2.2.1 At the stage of development of the SPS engineering design, conceptual schemes of the SPS components transportation and installation on the site, which provide a basis for subsequent development of the marine operation project regarding delivery and installation of the SPS shall be elaborated. Basic requirements for transport craft and cargo-handling gear (cranes, winches, pontoons, etc.) shall be prepared.

2.2.2 The following shall be identified:

limiting distributed and concentrated loads acting on the SPS component structures and securing devices during transportation to the installation site ([refer to Part XII](#) "Marine Operations");

limiting distributed and concentrated loads acting on the SPS component structures and hoisting eyes during operations for removal of the SPS components from the means of transportation and their installation on the site;

loads acting on the structures of the SPS components installed on the seabed or foundation till installation of the specified anchoring devices;

mutual loads on the structures of the individual SPS components during mounting.

2.2.3 It is necessary to make buoyancy and stability calculations for the means of transportation since the moment when the SPS components come into contact with water surface till the moment when they are installed in standard position.

2.2.4 For the SPS components to be dismantled during repairs, modernization or utilization it is necessary to identify loads during repair, surfacing, stowage on the means of transportation and transportation.

2.2.5 For the umbilicals, it is necessary to identify loads acting thereon during laying, including loads arising due to internal pressure, vessel movement, from laying equipment, loads during securing, during burial operation, loads from filled-up ground and during hoisting.

2.2.6 When developing technological process of umbilical laying, consideration shall be given to the following parameters (depending on the peculiarities of the SPS position):

allowable distances between the point of the umbilical contact with ground and the vessel in a seaway and under current effect;

tension value and bending radius of the umbilical depending on the sea state and current, identification of sections with maximum total stress and minimum radius of curvature;

allowable value of the vessel movement to prevent impermissible stresses in the umbilical;

maximum time period, depending on the sea state, during which the laying vessel can retain its position until impermissible stresses arise in the umbilical;

value of the fatigue stresses in the umbilical and its fittings;

loads when filling in by rocky ground;

longitudinal strains brought about due to storage and drawing of the umbilical through the laying device, in combination with tensile load;

where the laying process provides for drawing through pipes with different radii of curvature, it is necessary to determine the maximum tension force of the umbilical with due consideration for the umbilical friction against the seabed and friction inside the pipe.

2.3 FUNCTIONAL LOADS IN SERVICE

2.3.1 Functional loads during the SPS service are associated with influence of the following factors which shall be taken into consideration in designing:

proper weight of the SPS structures and equipment (with consideration for possible deposits of seabed soil and for marine growth);

weight and pressure of liquids and gases in the SPS systems;

residual stresses in structures;

thermal deformations of structural members;

deformations due to thermal expansion of liquids and gases in the SPS systems;

response to action of mechanical drives;

response to action of liquid and gas flows in the SPS systems;

response to external actions of tools during down-hole performance, as well as during drilling of additional wells being part of the SPS in operation.

2.3.2 When designing the SPS, consideration shall be given to the loads:

due to laying/installation of discharge pipelines connecting wells and individual components of the SPS;

due to thermal effect of well fluids on wellhead equipment, casings and connected pipelines;

additional loads due to deviation of the well from vertical position.

2.3.3 The design values of the SPS functional loads and the methods used for determination thereof shall be agreed with the Register.

PART IV. FOUNDATIONS

1 GENERAL

1.1 APPLICATION

1.1.1 The requirements of this Part apply to the foundations used for installation of the SPS equipment thereon during construction of the oil and gas fields.

1.1.2 The items of the Register technical supervision, as applied to the SPS foundations, are given in the SPS Nomenclature — refer to [Table 6.1](#) of Part I "General Regulations for Technical Supervision".

1.2 GENERAL REQUIREMENTS

1.2.1 The foundations shall ensure a horizontal supporting surface, positioning and fixing of the SPS on the seabed, taking-up and distribution of weight load incurred by the SPS components and forces arising in the process of the SPS installation and operation.

1.2.2 The SPS components may be installed on structural foundations, filled-up underbases, directly on the seabed or combination thereof.

1.2.3 The foundations shall ensure positive anchoring of the SPS components in all cases of combined effect of loads assumed as the design ones.

1.2.4 The foundations shall allow for thermal expansion of the SPS equipment during installation and operation.

1.2.5 The foundations for the wellhead equipment of wells with subsea injection may serve at the same time as a template for subsequent drilling and tie-in of additional wells. When drilling single (satellite) wells a temporary guidebase (TGB) as well as a permanent guidebase (PGB) may be installed (refer to [1.1.4](#) of Part VI "Wellhead Equipment").

1.2.6 Selection of the areas wherein the SPS components to be installed shall minimize the environmental risks and risks for the sea bioresources.

1.2.7 The SPS foundations shall be manufactured and installed in accordance with technical documentation approved by the Register.

2 SEABED SOIL INVESTIGATION

2.1 The design of the foundations for the SPS components shall be based on the results of the geological engineering survey of the site including site geology study, bottom topography study, determination of relevant properties of the foundation soils.

The physical extent of the seabed investigation is dependent upon uniformity of the soil and type of the SPS structures to be installed.

2.2 Special attention shall be paid to the potential risk of mudslides and scouring phenomena.

2.3 The area for installation of the SPS components foundations and value of burial into the seabed soil shall be selected to minimize influence of lithodynamic processes on the operability and reliability of the SPS components.

2.4 Where possible, the area for installation of the SPS components foundations shall avoid permafrost zones.

2.5 Prior to mounting and installation of the SPS components foundations additional site investigations shall be carried out when:

period of time since completion of the working engineering survey till commencement of mounting operations is two years and more;

significant changes in seabed soil conditions are likely to have occurred;

expected positions of the SPS components foundations are in the areas exposed to hazardous effects, e.g. seismically hazardous effects;

new objects, pipelines, etc. are present in the areas.

2.6 The requirements of [2.1.7](#) of Part III "Operational Conditions and Design Loads" shall be taken into account.

2.7 Possible changes of the soil properties due to the thawing of gas hydrates and thawing of sea bed soil, including as a result of changing climatic conditions and heat transfer from the SPS in general, shall be taken into account.

3 STRUCTURAL FOUNDATIONS

3.1 GENERAL

3.1.1 Among the structural foundations of the SPS are special structures made of metal or ferroconcrete. Fibre reinforced polymers may be used only if agreed with the Register.

3.1.2 Structural gravity-based foundations are anchored on the seabed by gravity (with consideration for ballast) or by anchors/piles secured by various ways.

Some components of the SPS may be secured by vacuum skirt underbases pressed into the seabed.

3.1.3 Prior to installation of the structural foundations engineering underwater, works to level the seabed area and removal of foreign objects shall be carried out.

3.1.4 The SPS components shall be properly connected to the foundations by mechanical devices (anchors, locking mechanisms) or by grouting.

3.1.5 The foundation design shall allow for dismounting of the SPS components during repairs and modernizations, as well as during utilization.

3.1.6 The structural foundation may be part of the very SPS (SPS component) and set on the seabed together with the latter as a common module.

3.1.7 The SPS foundations shall incorporate means for monitoring horizontal position thereof during mounting.

3.2 TEMPLATES

3.2.1 The template shall be a structure (as a rule consisting of a tubular metalwork and a foundation), arranged so as to support the SPS equipment.

3.2.2 The template may be of modular and single-piece design. The modular design implies step-by-step lowering of the equipment to the installation position. The single-piece design implies complete fitting-out of the supporting base with the SPS components prior to lowering to the installation position.

3.2.3 All pulled out modules and structures shall be anchored to the template by locking mechanisms.

3.2.4 Generally, not more than 12 openings for wells, with consideration for 2 — 3 stand-by expansion openings for drilling wells in case of failure of a running well or modernization of the SPS, shall be provided.

3.2.5 The allowable deviation of the wellhead seat axes from the vertical shall not exceed 3°.

3.2.6 The facility for leveling of the template shall be equipped with locking mechanism for connection to the guiding body of securing pile.

3.2.7 The template shall be leveled on the seabed with the use of a level gauge and controlled with the use of subsea video systems or by other methods ensuring the required accuracy of the operation performed.

3.2.8 At least, 4 openings are recommended to be arranged in the template for the purpose of piled anchoring it on the seabed. Subject to proper substantiation and special consideration by the Register, the number of openings for piles may be less than 4.

3.2.9 Diameter of the piles and depth of their burial into the seabed shall be determined depending on engineering — geological conditions of the seabed soil and along with that, consideration shall be given to level of vibrations induced by the well fluid flow and operation of the equipment. The methods of calculation of the piled template anchoring on the seabed shall be agreed with the Register.

Designing pile fastening of SPS, the possibility of initiation and local seabed scouring development shall be taken into consideration. Local scouring characteristics may be recommended to be determined by the procedures or model tests approved by RS. For reduction or exclusion of scouring occurrences anti-scour protection may be performed around FOP.

3.2.10 The pile design shall be selected proceeding from the conditions of reliable and safe operation of the SPS throughout the service life and shall meet the criteria of the bearing capacity of the pile base specified in 4.2.2.2 of Part II "Hull" of the FOP Rules, as far as applicable. The service life of the template shall correspond to the service life of the field and comprises generally 25 — 30 years.

3.2.11 A sonar system for remote detection of a subsea well cluster shall be installed on the template.

3.2.12 The mechanism for fixing guides shall be so designed as to preclude its spontaneous operation, including operation due to action of external objects (ropes, wire, cables, etc.). The guides shall have a through hole down to the seabed to secure the guide line anchor.

3.2.13 The template structure shall provide for performance of works for cleaning and servicing from a ROV of the locations wherein connectors, platforms, etc. are joined.

3.2.14 Where necessary, the template shall provide for installation of additional equipment used during drilling and servicing of wells.

3.2.15 The template shall rest on an even sea floor, the inclination allowed being not more than 3°.

4 SEABED SUPPORTED STRUCTURES (FOUNDATIONS)

4.1 Where the vertical and horizontal bearing capacity of seabed soil has appropriate characteristics, the seabed may be directly used as a base for installation of the SPS components.

4.2 In separate cases, where the seabed is prepared for installation of the SPS, the seabed portion concerned shall be grouted.

4.3 Where the bearing capacity of the seabed in the area of the SPS installation is insufficient an additional seabed supported structure (foundation) may be required.

5 BURIED STRUCTURES (FOUNDATIONS)

5.1 In the case of buried structures (foundations), it is necessary to consider horizontal loads caused by the soil and to prevent collapse or scouring of the trench side walls until the works for installation of foundation are completed.

PART V. PROTECTIVE STRUCTURES

1 GENERAL

1.1 All SPS components shall be protected against accidental impacts (caused by icebergs, fishing gear, dragged anchors, dropped objects, etc.) by special structures.

Measures for protection of the SPS against accidental impacts to be considered are as follows: use of protective guards, arrangement of equipment in strong (tight) compartments, burial of the SPS components into seabed soil, etc.).

1.2 Limiting loads for which the protective structures are designed, and schemes of the protective structures shall be especially developed to fit the design and arrangement conditions of a particular SPS and shall be approved by the Register.

1.3 The protective structures used shall make access to the SPS components possible for inspection, maintenance and repair in accordance with the adopted methods and process charts of maintenance.

1.4 For flowlines, and umbilicals, a combination of protective elements shall be used as follows:

- trenching;
- mattresses;
- rock dumping.

1.5 Electrochemical protection shall be designed as per applicable requirements in [1.3.6](#) and [1.3.7](#) of Part II "General Requirements for Design of the Subsea Production Systems" of these Rules.

1.5.1 To prevent snagging from fishing gear, the sacrificial anodes of the electrochemical protection system shall be located inside the protective structure. At the same time, access to the sacrificial anodes of the protective structure shall be provided for visual and instrumental monitoring of the state of electrochemical protection by ROV.

1.5.2 Protective structures shall ensure the continuity of the electrical circuit between all components under electrochemical protection.

1.6 The protective structure shall facilitate the tie-in of flow lines (flow line tie-in shall be effective regardless of selected tie-in system).

1.7 For over trawl able structures, the following recommendations apply:

- protective structure shall deflect all fishing equipment;
- vertical structural corners shall have maximum true angle of 58° from the horizontal, optimized to assist trawl and trawl-wire deflection;
- corners, ramps and equivalent structures shall penetrate the seabed to avoid snagging from trawl warp lines;
- overall geometry of the structure and the size of openings shall be such that trawl doors are prevented from entering into the structure;
- if vertical side bracings are included, these shall be spaced to prevent intrusion and rotation of trawl equipment, without restricting subsea structure access for maintenance;
- all protrusions shall be designed to prevent snagging of nets;
- all external members which are not part of a closed protective structure shall have a minimum radius of 250 mm.

1.8 When designing protective structures, including protective cap and hatches, dropped-objects and fishing-gear loads shall be taken into account in accordance with GOST R 59305 (Appendix F, Form F5).

1.9 Confirming calculations of the bearing capacity of the protective structure shall be submitted to the RS. When designing the load-bearing and protective members of the protective structure, the loads sustained by the equipment during transportation, lifting operations in air and water, mounting, installation and operation shall be taken into account.

The analysis shall be carried out taking into account the recommendations specified in ISO 13628-15.

1.10 It is recommended that the mating of protective structures be checked using the module on which it is installed, or a dummy. The dummy shall fully replicate the profile geometry of the mating element.

1.11 Components of protected equipment shall not protrude beyond the frame of the protective structures.

1.12 The handles and controls for ROV shall be manufactured in accordance with ISO 13628-8.

1.13 The controls for connecting ROV shall be protected from mechanical damage during lifting and mounting operations, positioning and docking of ROV.

2 STRUCTURES RELIEVED OF HYDROSTATIC PRESSURE

2.1 Protective structures relieved of the seawater hydrostatic pressure shall be designed for specific loads in compliance with their functional purpose.

2.2 Attachment points of the protective structures specified in [2.1](#) shall be designed for thrice-increased static loads applied thereto.

2.3 At the localities susceptible to impacts during transportation, installation, surveys and repairs the protective structures shall be locally strengthened, where necessary. Unless these conditions are especially specified, it is necessary to proceed from possible acceleration in any direction, equal to $3g$.

2.4 Substantial yielding of the protective structure to accidental loads of low probability may be allowable if this is documented by the results of risk and failure effect analysis and by specified procedure of repair (replacement) of the damaged protective structure.

2.5 The height of the protective structure shall be minimized and such that deformation of the roof caused by dropped-object impact does not result in contact of the roof with the SPS equipment. This shall take into account the provisions of ISO 13628-8 with regard to allowing ROV access to protected equipment.

2.6 Lifting lugs or other structural elements intended for transportation and installation of equipment in accordance with GOST R ISO 13628-4 shall be located on the protective structure.

2.7 Design calculations of lifting/mounting operations shall be carried out. The calculation shall be conducted taking into account the applicable requirements in ISO 10855-1 and ISO 10855-2.

2.8 The calculation shall contain the list of initial data, control criteria, description of the design scenarios, description of the methodology and software used, calculation results and conclusions based on the calculation results.

2.9 The calculation shall contain information about the monitored parameters of the equipment condition, which make it possible to unambiguously determine the possibility of performing the planned operations.

2.10 All blank and enclosed load-bearing structural components of the protective structure made of shaped and round pipes, as well as those made of metal sheets by rolling, shall have openings for filling with water and air escape when submersed and to ensure equalization of external and internal hydrostatic pressure when the depth changes during installation.

2.11 To reduce hydraulic resistance in submersing the protective structure into water and to facilitate the splash zone transfer, all horizontal protective elements of the protective structure, such as metal or glass fibre reinforced sheets, shall have openings for the passage of water and air. The openings shall not affect the function of the equipment and its components.

2.12 The geometric dimensions of the hatches and mounting openings in the roof of the protective structure shall allow the mounting/dismounting of the protected equipment, its removable components or SPS equipment to be connected.

2.13 The design of lifting devices for lifting operations shall provide for the possibility of unhindered dismounting/mounting of removable protective hatches.

2.14 To provide access to protected equipment, the weight of moving and removable modules of the protective structure dismantled by ROV shall be selected taking into account the allowable handling capacity of the ROV's manipulator.

2.15 Moving and removable parts of the protective structure shall include locking mechanisms and open/closed position indicators with interfaces for control by ROV.

2.16 Moving and removable modules of the protective structure shall have a guidance and positioning system. When designing removable components of the protective structure, it is necessary to include a guidance system for mounting/dismounting.

2.17 The protective structure of the subsea wellhead system shall ensure that the corrosion inhibitor can be supplied to the wellhead production bore of the subsea wellhead system using ROV.

2.18 For the protective structure of the subsea wellhead system, it is recommended to have height-adjustable supports. It shall be ensured that the supports are penetrated at least 300 mm into seabed soil to avoid the risks of protective structure snagging from fishing gear and its tipping over.

2.19 Fixation of the protective structure of the subsea wellhead system at the wellhead is provided by the weight of the structure and the structural element with a cylindrical surface to ensure radial contact with the mating cylindrical surface of the subsea wellhead system in order to limit movement in the horizontal direction. It is allowed to use locking mechanisms.

3 STRUCTURES DESIGNED FOR HYDROSTATIC PRESSURE

3.1 Protective structures designed to take up hydrostatic pressure of seawater shall comply with the requirements of the MS/DS Rules.

3.2 The value of the working hydrostatic pressure depends on depth of the area wherein the SPS (SPS component) is installed on the field with due regard for seawater density, likely tides and currents, as well as the depth of the SPS (SPS component) penetration into the seabed soil.

3.3 The number of entries of electric cables and pipelines, as well as tie-rods of various purpose into the tight protective structures shall be, where possible, kept to minimum.

3.4 Subsea facilities (submersibles, diving bells, etc.) intended for delivery and salvage support to personnel accommodated within the tight protective structures shall be subject to review by the Register for compliance with the requirements of the MS/DS Rules.

PART VI. WELLHEAD EQUIPMENT

1 GENERAL

1.1 COMPOSITION AND PURPOSE

1.1.1 The wellhead equipment system of a well cluster with subsea completion, as a rule, shall consist of:

- a guidance system to subsea wellheads;
- a subsea wellhead assembly;
- remote control systems for the assembly and manifold.

1.1.2 The wellhead equipment system shall ensure:
performance of operations for wellhead sealing, as well as isolation of a tubing-casing annulus with control over the pressure therein;

hydraulic and mechanical connection of subsea wellhead with deck equipment of the FPU/MODU/FOP;

detection of subsea wellhead cluster and location thereof;
connection of the other SPS functional units with the subsea wellhead;
remote control of operating mode of the subsea well cluster with monitoring of operation parameters;

- possibility of injecting chemical agents into the well;
- killing, including emergency killing of each subsea well within the cluster;
- automatic shutoff of borehole in emergency situations;
- protection of the equipment against corrosion and marine growth;
- performance of maintenance, including repair, operations with the use of ROV.

1.1.3 Ships (craft) from which operations for installation of the wellhead equipment are carried out shall meet the requirements for installation of specific equipment accounting the occurrence of emergency situations and likely ship drift.

1.1.4 A typical subsea wellhead system, as a rule, shall consist of the following major components (refer to Appendix 1):

.1 a TGB with a central opening for drilling of the first section of the well and facilities for attachment of guidelines;

.2 a PGB with facilities for attachment to the conductor housing and guidance of the drilling and completion equipment (universal guide frame, blowout preventer, production tree);

.3 a low-pressure conductor housing which incorporates an internal landing shoulder for the wellhead housing, and facilities on the outside for attachment of the permanent guidebase;

.4 a casing head housing with internal profiles for support of all subsequent casing strings and the tubing hanger, and external profiles for attachment of the drilling and completion equipment (blowout preventer, tree) and landing in the low-pressure conductor housing;

.5 various casing hangers with associated annulus sealing assemblies for suspension of the casing strings and isolation of the annulus.

1.1.5 The standard range of working pressures (pressure ratings) for the casing head equipment, main and attached equipment operating underpressure (valves, choke valves, housings, connectors, etc.), as a rule, shall comprise: 13,8; 20,7; 34,5; 69,0; 103,5 and 138,0 MPa.

1.1.6 Together with the wellhead system, the WHA and the tubing hanger shall provide the barriers between the reservoir and the environment. In the installation/ workover mode, the barrier functions are transferred to the LRP for VXT, BOP systems and landing string of large diameter for HXT systems.

1.1.7 The wellhead equipment shall be manufactured according to the technical documentation approved by the Register. The items of the Register technical supervision, as applied to the wellhead equipment, are given in the SPS Nomenclature — refer to [Table 6.1](#) of Part I "General Regulations for Technical Supervision".

2 REQUIREMENTS FOR THE WELLHEAD EQUIPMENT

2.1 GENERAL

2.1.1 Operational conditions (pressure rating, temperature and other well parameters) shall be defined for each kind of equipment.

2.1.2 In designing of the subsea wellhead equipment, consideration shall be given to all functional loads arising in the process of well drilling and completion, workover and operation (including loads specified in [2.3.2](#) of Part III "Operating Conditions and Design Loads"):

temporary, when a drilling marine riser and well completion/workover riser (CWO) systems are installed in the wellhead system;

permanent, when a flowline/production riser or riser/delivery line is attached to the wellhead system.

2.1.3 The basic characteristics of the subsea wellhead equipment are as follows:

maximum working pressure on the wellhead which may arise during operation, including shutdown or workover;

nominal inside diameter of the through hole.

2.1.4 The number of the running subsea wells on the same base, as a rule, shall not exceed 10.

2.1.5 The wells shall be so spaced apart as to ensure ease of installation, maintenance during operation, but, as a rule, at not less than 5,5 m, and the distance between the rows shall not be less than 3,5 m.

2.1.6 The wellhead equipment shall be designed for operation within the range of working temperatures to be determined in accordance with the requirements of ISO 10423 with due regard for the possible heating or cooling during operation (e.g. Joule-Thompson effect, pumping of heated liquids, etc.)

Consideration shall be given to the effect of the temperature gradients, temperature cycles for the metal and non-metal equipment parts.

2.1.7 The casing head attachment system and the LPMV/UPMV shall remain operable after being subjected to the action of the typical accidental loads (refer to [2.1.10](#) of Part III "Operational Conditions and Design Loads").

2.1.8 Materials shall be selected in accordance with the requirements of [1.2](#) of Part II "General Requirements for the Design of the Subsea Production Systems" and recognized standards.

2.1.9 Flanges, shaped parts, gaskets and seals, fasteners for the subsea systems shall comply with the requirements of 7.1, 7.2 and 7.3 of ISO 13628-4.

2.1.10 Casing heads, casing hanger assemblies, tubing hanger spools, as well as all the assemblies under pressure, except for the drilling mud line assemblies shall be designed in accordance with the requirements of ISO 10423.

2.1.11 Lifting devices and guidance systems shall comply with the requirements of Annex K to ISO 13628-4. It is recommended that a safety factor of 1,5 is taken for the calculations. The need to change the value of the safety factor is subject of special consideration by the Register. For calculations relevant to the workover risers the requirements of ISO 13628-7 are applicable.

2.1.12 It is essential to ensure interchangeability of individual components and units of the equipment, if the requirements for functioning allow this. The interchangeability between the WHA, tubing heads, caps, instrumental interfaces, etc. shall be ensured at the design stage.

2.1.13 All the hydraulically operated equipment which is not in direct contact with well fluids shall remain operable in cases where pressure in the hydraulic drive system is varied through a range from 0,9 up to 1,1 times the established working pressure.

2.1.14 The X-mas tree package shall have marking which bears, as a minimum, the following information:

name, location of the manufacturer, date of manufacture;

designation of the block (package);

working pressure;

working temperature;

material class (including the maximum allowable partial pressure of hydrogen sulphide);

serial number.

2.1.15 Equipment designed with threaded joints (except for casing and tubing heads) shall have sizes and working pressures as given in [Table 2.1.15](#).

Table 2.1.15

Equipment	Diameter, mm	Working pressure, MPa
Pipes (linear portion)	12,7	69,0
	From 19,1 up to 50,8	34,5
	From 63,5 up to 152,4	20,7
Tree piping	From 26,7 up to 114,3	34,5
Casing strings	From 114,3 up to 273,1	34,5
	From 298,5 up to 339,7	20,7
	From 406,4 up to 508	13,8

2.1.16 General requirements for various types of the wellhead equipment are given in Annexes A3, A4 and A5 to ISO 13628-1.

2.2 WHA AND TUBING HEAD CONNECTORS

2.2.1 Three types of connectors shall be commonly used:
 hydraulic remote operated;
 mechanical remote actuated;
 mechanical diver/ROV operated.

2.2.2 All connectors shall be designed by size, pressure rating consistent with the type of the casing head to which they will be attached ([refer to Table 2.2.2](#)). The WHA connectors shall conform to standard working pressure ratings as given in [1.1.5](#).

Table 2.2.2

System size		BOP stack configuration	High pressure housing working pressure		Minimum vertical bore	
mm – MPa	in – psi		MPa	psi	mm	in
476 – 69	18 3/4 – 10 000	single	69,0	10 000	446	17,56
476 – 103	18 3/4 – 15 000	single	103,5	15 000	446	17,56
425 – 35	16 3/4 – 5 000	single	34,5	5 000	384	15,12
425 – 69	16 3/4 – 10 000	single	69,0	10 000	384	15,12
527 – 540 – 14	20 3/4 – 21 1/4 – 2 000	dual	13,8	2 000	472	18,59
346 – 69	13 5/8 – 10 000	dual	69,0	10 000	313	12,31
540 – 35	21 1/4 – 5 000	dual	34,5	5 000	472	18,59
346 – 103	13 5/8 – 15 000	dual	103,5	15 000	313	12,31
476 – 69	18 3/4 – 10 000	dual	69,0	10 000	446	17,56
346 – 103	13 5/8 – 15 000	dual	103,5	15 000	313	12,31

2.2.3 The connector body proof pressure shall be 1.5 times the working pressure. Possible effect of the well fluid pressure due to leakage of the surface controlled sub-surface safety valve shall be considered. The connector may be a separate unit or may be integral with the X-mas tree valve block.

2.2.4 The remotely operated connector shall be equipped with an external position indicator suitable for observation by diver/ROV.

2.2.5 The connector shall be provided with a self-locking mechanism to prevent release due to loss of hydraulic locking pressure. The design of mechanical locking devices shall consider release in the event of failure to the primary actuating system or other damages.

2.2.6 The design of the connector shall ensure that trapped fluid does not interfere with the operability thereof.

2.3 WELLHEAD EQUIPMENT DESIGN

2.3.1 The wellhead equipment shall be so designed as to ensure pumping-out or injection of fluids both into the well tubing and into the annulus.

2.3.2 All system components which during operation will be brought to surface shall be equipped with necessary devices for slinging. All packages with weight of 10 t and more, as a rule, shall have special openings in the frame (housing) for seafastening during transportation.

Mounting surfaces and connectors shall be protected against possible damages during transportation. All seal surfaces, for the period of storage, transportation and mounting shall be protected by readily retrievable protective covers.

2.3.3 The wellhead equipment shall be provided with cathodic protection system.

2.3.4 Provision shall be made for the use of ROV to carry out replacements of individual units of the equipment. ROVs employed on the field concerned shall be adapted for dealing with all the types of equipment used.

2.3.5 Equipment which shall be mounted and dismantled on the field shall ensure performance of these operations with the mating surfaces being out of parallel by up to 1,5 °C.

2.3.6 Equipment the servicing of which requires entry of the personnel into the modules shall be fitted with ladders, platforms, guards in accordance with the recognized safety standards and rules. Where necessary, passageways and ladders shall be arranged between modules.

2.3.7 Hydraulic cylinders of the mechanisms for locking connections shall be in retracted position when the connector is locked.

2.3.8 For installation and attachment of units having guidelines, use shall be made of a three-stage installation system, incorporating guide cables, connector housing and guides for precise installation.

2.3.9 WHA constructions of other large-sized units shall be designed in such a way as to be stable without additional supports (frames). To impair additional stability and reduce load on individual equipment items, use of additional frames, supports and bases is permissible.

2.3.10 All joints shall be so designed that in the event of failure to the primary control system the equipment can be capable of being controlled using mechanical actuators.

2.3.11 All detachable joints shall be designed in such a way as to preclude spontaneous release due to effect of vibration, external loads, temperature stress and other kinds of effects on the locking mechanism.

2.3.12 Strength of the wellhead equipment body components is assessed by proof pressure testing conducted at 1,5 times the working pressure for the nominal inside diameter more than 350 mm, while at the nominal inside diameter equal to or less than 350 mm the proof pressure over the working pressure range from 13,8 up to 34, 5 MPa is assumed to be 2,0 times the working pressure, over the range from 69,0 up to 138,0 MPa — 1,5 times the working pressure.

2.3.13 The well shall be equipped with SCSSV. The control post of the surface controlled sub-surface safety valves and remote control of the wellhead assembly gate valves shall comply with the requirements of [Part XI](#) "Systems for Monitoring, Control and Emergency Protection".

2.3.14 The wellhead equipment shall provide monitoring of pressure in tubing and annulus.

2.3.15 Wells, pipelines, etc, shall be blown and discharged through the blowing and discharging unit.

3 SUBSEA WELLHEAD ASSEMBLY

3.1 GENERAL

3.1.1 The WHA shall generally include:
X-mas tree;
tubing hanger;
sub for mounting the tubing hanger housing on the equipment of the mudline casing hanger;
tree cap.

3.1.2 Major functional packages being part of other SPS systems may also be installed on the subsea WHA.

3.1.3 The subsea WHA shall be so designed as to provide vertical access to the production bore (PT channel) to perform works for inducing inflow, supplying working fluid to the surface controlled subsurface safety valve, as well as to perform the well workover operations.

3.1.4 The X-mas tree shall ensure wellhead sealing, control over the well production conditions and performance of the well control and workover operations.

3.1.5 As a rule, the X-mas tree incorporates:
housing of monoblock type;
monoblock to tubing head housing connector;
gate/shutoff valves;
guide frame;
stab pockets for the PT;
side outlets with connectors.

3.1.6 The X-mas tree monoblock shall be made of anticorrosive material. All flange and butt joints of the X-mas tree components shall be sealed with the use of metal gaskets of appropriate standard.

3.1.7 All gate/shutoff valves of the subsea WHA shall have:
hydraulic actuator with gate position indicator;
non-return valves for periodic injection of protective lubricant into the housings in order to prevent accumulation of mechanical impurities;
pressure and temperature pickups at the wellhead with transmission of their readings to control panel;
gate position (open/closed) pickups.

3.1.8 Type of the wellhead assembly shall be defined by the design approved by the Register. The SPS shall preferably be provided with a wellhead assembly of a single type: VXT or HXT.

Basic types of X-mas tree are described in [Appendix 2](#).

3.1.9 Basic requirements for VXT and HXT valving and the requirements thereof shall comply with 6.2 of ISO 13628-4.

3.1.10 The subsea WHA is controlled with the use of a hydro-power plant arranged on the FPU/FOP used for the SPS control. The requirements for the hydro-power plants are set out in [Part XI](#) "Systems for Monitoring Control and Emergency Protection".

3.1.11 The WHA shall be equipped with pressure monitoring points for indication and pressure testing of valves. The necessity of pressure monitoring points for ESD shall be specified by design.

3.2 SHUTOFF AND CONTROL VALVES. VALVES AND THEIR ACTUATORS

3.2.1 All the tree gate valves shall have double-side sealing and be operable under static pressure in the well while in closed position.

3.2.2 Vertically installed tree valves (in tubing and annulus space) shall be actuated mechanically by ROV.

3.2.3 The gate position indicators shall be installed on all valves and actuators, they shall be clearly readable by the ROV's video systems at all types of control, arrangement of tools and manipulators.

3.2.4 Shear pin subs which are intended for manipulations with ROV shall not be used where permanent valve control is provided.

3.2.5 Hydraulically operated valves shall incorporate ability to be closed safely in the event of failure to the hydraulic system.

3.2.6 The design of the shutoff valves, their actuators, connecting flanges shall meet, as a minimum, the requirements of 7.10 of ISO 13628-4.

3.2.7 The choke valves and their actuators shall meet, as a minimum, the requirements of 7.21 of ISO 13628-4.

3.3 VERTICAL X-MAS TREE CAP

3.3.1 The cap shall be installed and locked onto the re-entry hub of the X-mas tree and shall protect sealing surfaces and hydraulic system joints used for separable equipment. Depending on the solutions adopted in the design, the cap may be pressure-containing or non-pressure-containing.

3.3.2 In case where a tree cap permanently kept under pressure is used, hydraulic link between the cap and equipment used shall ensure performance of the following functions:

- locking/unlocking of the cap connector, if there is a hydraulic actuator;
- control over the cap seal tightness;
- depressurization;
- possibility of dismantling with ROV intervention.

3.3.3 General requirements for the tree cap handling tools shall meet, as a minimum, the requirements of 7.13 and 7.14 of ISO 13628-4.

3.4 CASING HEAD HOUSING

3.4.1 The working pressure shall comply with the specification approved by the Register, but not be less than 69,0 MPa.

3.4.2 Provision shall be made for a sufficient number of places for securing and sealing of casing strings specified by the well program.

3.4.3 All supports, seals and other components the replacement of which is likely to be required during operation shall be designed so that they can be replaced using individual units, without damage to sealing surfaces.

3.4.4 The casing head shall be equipped with a standard protective anticorrosive means.

3.4.5 The casing head system shall be provided with an outlet connection to carry off well drilling cuttings and well fluid to a dedicated zone on the seabed.

3.5 TUBING HEAD

3.5.1 The subsea WHA tubing head shall provide for tubing hanger and meet the following requirements:

the tubing hanger shall be so designed as to seal the annulus between the tubing string and casing string;

the tubing hanger shall be of female type, equipped with a hydraulically actuated locking mechanism, as well as packers for sealing thereof in the housing;

the hanger shall pass freely through the drilling riser and BOP assembly;

the tubing hanger shall include provision for down hole hydraulics lines for control of the SCSSV;

it shall be possible to release the tubing hanger locking mechanism using a separate mechanical device, in case of emergency.

3.5.2 The tubing heads shall be designed by size, pressure rating and profile types of their top and bottom connections. The tubing head and connector may be manufactured as an integral unit. The range of the working pressures for the tubing heads shall conform to that given in [1.1.5](#). In case, where the tubing head and connector are manufactured as an integral unit, the pressure rating shall apply to the unit as a whole. The test pressure shall be 1,5 times of the working pressure.

3.5.3 Hydraulically actuated tree and tubing head connectors shall be capable of containing hydraulic release pressures of at least 1,25 times hydraulic rated working pressure. The connector design shall provide greater unlocking force than locking force.

3.5.4 Hydraulically actuated systems shall be designed with a secondary (back-up) release method which may be either hydraulic or mechanical.

3.5.5 Seal surfaces shall be inlaid with material which does not corrode in seawater and does not enter into a reaction with injected fluids. Inlays are not required if the base seal material meets these requirements. Design of the seals shall allow for their simple and safe replacement.

3.6 GUIDE FRAME OF X-MAS TREE

3.6.1 The guide frame of the X-mas tree shall ensure:

ROV mooring for performing all necessary operations (operation of valves, connectors, replacement of individual assemblies and units, etc.);

protection against mechanical damages to X-mas tree during transportation and mounting;

possibility of visual inspection of the WHA by ROV.

3.6.2 The guide frame of the X-mas tree shall incorporate built-in structures for protection of the valve actuators and other equipment. The protective structures shall withstand impact load of 10 kJ over an area bounded by a circle with a diameter of 100 mm.

3.6.3 Strength calculation shall be made with due regard for loads from tools and ROV arising during execution of works.

3.6.4 All systems for interaction with ROV shall be arranged on the X-mas Tree module such that they can be readily accessed by the ROV in a horizontal position. The primary ROV access point for the X-mas tree and WHA shall be a vertical panel sited on the tree module.

3.6.5 The technical requirements for the guide frame and its equipment shall conform to the requirements of 7.15 of ISO 13628-4.

3.7 LOWER RISER PACKAGE (DRILLING/WORKOVER)

3.7.1 The technical requirements for the LRP shall conform to the requirements of the standards recognized by the Register, in particular, ISO 13628-7. As a rule, the LRP shall consist of the following equipment which shall ensure the following:

- .1** direct and full access to the tubing and annulus space without any restrictions;
- .2** PT shall be fitted with at least two ram blowout preventers which shall be hydraulically actuated to preclude spontaneous movement of the rams in closed position. The maximum closing time of the preventers shall not exceed 20 s;
- .3** distance between the top and bottom preventers shall be sufficient to accommodate a pipe section of not less than 0,25 m in length, that is the distance shall be of 0,25 m + preventer height;
- .4** top rams shall be of blind-shear type and shall ensure shearing of flexible pipes, cables and other well equipment listed in the customer's specification;
- .5** bottom rams shall ensure sealing of the well with run in pipes the size of which is specified by the customer,
- .6** hydraulic system of the bottom preventer (with tubing rams) shall allow for its re-opening after disconnection of ROV;
- .7** place shall be provided on the annulus line for installation of an emergency hydraulically actuated gate valve capable of shearing wire when being closed;
- .8** package shall incorporate a top ram capable to shear a braided cable when being closed;
- .9** package shall incorporate a hydraulically actuated cross-over valve which transfer the system to safe condition when being closed;
- .10** provision shall be made for injection of displacing fluid into the tubing through the riser connected to the annulus, with the preventer closed.

3.7.2 The LRP shall allow for safe disconnection of the service riser without discharge of the well fluids to the environment under all operational conditions.

3.7.3 All the basic surface controlled safety valves of the tree shall be closed in the event of disconnection of the riser between the upper and lower connection points during performance of works.

3.7.4 The connectors shall incorporate ability to be released by ROV in case of failure to the primary system.

3.7.5 All valves, rams and their locking devices shall be equipped with gate position indicators clearly readable by the ROV's video systems.

3.7.6 The LRP shall be capable of injecting chemical agents into the well.

3.7.7 All valves shall be capable of being operated by ROV. The cross-over valve shall be equipped with parallel slide gate valves with hydraulic actuation ensuring closed position upon loss of hydraulic power.

3.7.8 It is recommended that all shutoff valves (parallel-slide gate valves) shall be of the same type and size as the valves on the X-mas tree.

3.8 TREE CAP RUNNING TOOL (VERTICAL TREE)

3.8.1 The tree cap running tool may be combined with the emergency disconnect package (EDP).

3.8.2 The tool shall incorporate a hydraulic operated connector to connect to the tree cap re-entry hub.

3.8.3 The connector shall be designed to be released by ROV assistance independent of the primary system.

3.9 HYDRAULIC CONTROL SYSTEMS

3.9.1 The diameter of the system pipelines shall be consistent with the capacity of the valve and connector actuators in order to ensure the required actuation time (time of closing, position changing, etc.).

3.9.2 As a rule, pipes without intermediate joints shall be used in the systems. Detachable joints shall be fitted with metal-to-metal seals.

3.9.3 For connection to the actuators and for blanking off hydraulic tubing the thread connections shall be used, preferably that these are fitted with antivibration glands.

3.9.4 To minimize possible leaks, minimum number of welded joints shall be used. Allowable pressure for fittings, plugs and other elements of the hydraulic tubing, shall not be less than the design pressure in the control system.

3.9.5 The systems used to install multiport hydraulic receiver plates shall incorporate ability to adjust closely position of these plates with respect to the pipelines in order to preclude stressing in the pipeline joints during mounting.

3.9.6 The specific requirements for the hydraulic systems are set out in [Part XI](#) "Systems for Monitoring, Control and Emergency Protection".

3.10 SUBSEA WELLHEAD ASSEMBLY MOUNTING

3.10.1 The X-mas tree shall be oriented with respect to the guide posts (if any) of the base. It shall be installed, locked and sealed on the tubing head (for the vertical tree).

3.10.2 The X-mas tree shall incorporate necessary number of valves to control tightness of connections (barriers) and, as a minimum, one LPMV/UPMV. Other valves may be added, where necessary, during operation or workover.

PART VII. SYSTEMS FOR GATHERING AND TREATMENT OF WELL FLUIDS

1 GENERAL

1.1 APPLICATION

1.1.1 The requirements of this Part apply to:

discharge pipelines (flowlines);

manifolds intended to transport well fluids, injected fluids or gas (injection lines);

systems for subsea treatment of well fluids, water or gas injection into the formation.

1.1.2 The subsea pipelines not specified in [1.1.1](#) are also covered by the requirements of Part I "Subsea Pipelines" of the SP Rules, as far as applicable.

1.1.3 The systems for gathering and treatment of well fluids shall be manufactured according to technical documentation approved by the Register. The items of the Register technical supervision are listed in the SPS Nomenclature — refer to [Table 6.1](#) of Part I "General Regulations for Technical Supervision".

1.2 GENERAL REQUIREMENTS

1.2.1 In designing of the manifold and tree piping systems characteristics of particular formation and production fluids specified in [1.2](#) of Part III "Operational Conditions and Design Loads" shall be considered.

1.2.2 It is necessary to determine the design service life of the system with consideration of the expected normal and emergency modes for all possible ranges of flow rates, pressures, temperatures and compositions of the formation and production fluids.

1.2.3 In designing of the gathering and treatment systems, consideration shall be given to:

- well depth;
- reservoir pressure;
- fluid properties, percentage of ingredients and their variations throughout the field life (density, gas factor, watercut, viscosity, etc.);
- tie-back distance for the flowline from the well; water depth.

1.2.4 Arrangement of production equipment as close to the producing formation as possible will be preferable.

1.2.5 The system for gathering and transporting of well fluid shall, generally, include: flowlines ensuring gathering of the well fluids over the course from well to manifold unit; oil and gas gathering pipelines ensuring gathering of the well fluids over the course from manifold units to separators;

pipelines for transporting of the well fluids over the course from separator units to pumps or risers;

gas pipelines for transporting of the petroleum gas from separator units to risers or subsea gas compressors.

1.2.6 Based on data of the field development process chart, it is necessary to make a hydraulic calculation of the piping system, ensuring transporting/pumping of the formation and production fluids under all operating conditions for stationary/transitional modes of operating.

1.2.7 The hydraulic calculation of the gathering system pipelines when transporting oil-gas (oil-gas-water) mixtures shall be made according to standards recognized by the Register. The hydraulic calculation of pipelines shall be made for the following cases:

peak production of fluid taken from the process chart data, and viscosity corresponding to water encroachment over this period;

maximum viscosity and corresponding production of fluid.

1.2.8 The hydraulic calculation of pipelines when transporting fluid in single-phase state shall be made using the Darcy-Weisbach formula.

1.2.9 The hydraulic calculation shall be made according to standards recognized by the Register.

1.2.10 The minimum nominal bore of the flowline from oil well shall be generally assumed to be not less than 80 mm.

1.2.11 In designing of the flowlines for wax accumulating oils and/or oils having high viscosity (from 7,0 to 10,0 cm²/s) provision shall be made for:

- use of special internal coatings for pipes;
- mechanical cleaning of pipe internal walls from paraffin;
- solvent injection;
- heating and other measures.

1.2.12 In designing of oil conveying pipelines consideration shall be given to the rheological properties of the transported fluids with consideration for the environmental temperature at the laying depth.

1.2.13 Layout of the pipelines, arrangement of the manifolds and equipment of the system for treatment of well fluids shall provide for short-cut and straight routes and allow for compensation for stresses (due to difference of temperatures, pressures, etc.) arising during operation.

1.2.14 For protection of the pipelines against internal corrosion, provision shall be made for:

formation of the flow pattern preventing separation of phases and release of fluid;

corrosion inhibitor injection;

internal protective anticorrosive coating of pipes.

1.2.15 The design shall stipulate measures to preclude pressure increase in the pipelines above the design pressure under all operating conditions. All valves of the systems shall be equipped with actuators that allow remote and local control by ROV or divers.

1.2.16 Supporting and guarding structures of the piping, manifold assemblies and the systems for treatment of well fluids shall comply with the requirements of [Part IV](#) "Foundations" and [Part V](#) "Protective Structures".

2 SYSTEM FOR GATHERING OF WELL FLUIDS

2.1 SUBSEA GATHERING MANIFOLD

2.1.1 The subsea gathering manifold including piping and control line assembly shall be installed on the template (foundation) which also allows for attachment of pipes, valves, connectors and other devices. All shutoff and control valves of the manifolds shall, as a rule, have automatically or remotely controlled hydraulic actuators.

2.1.2 Depending on the composition of well fluids injection of hydrating, corrosion inhibitors, antifoaming and other reagents shall be ensured, Inhibition method shall be determined at the field development scheme elaboration stage. When selecting the inhibitor, water temperature near the seabed, and extension of the inhibitor injection pipeline shall be taken into account.

2.1.3 Depending on the characteristics of a particular field and adopted field construction scheme, subsea gathering manifolds of two types may be used:

conventional, which is intended for gathering fluids without any changes in pressure and other parameters;

choke, downstream of which the reservoir fluid pressure is reduced to a level necessary at the final point of the route in order to ensure safety and reliability of the processes run.

2.1.4 The choke subsea manifold shall provide for:

intake of the well fluids with their flow rate being measured for each subsea well with subsequent throttling and equalizing of pressure;

possibility of emergency killing of an individual well (at unchanged running of the remaining wells) up to its complete shutting-in with the aim of workover/investigation.

2.1.5 The manifolds may be made as a separate unit (separate SPS component) or may be structurally combined with the wellhead equipment on a common template.

2.1.6 Depending on the design of a particular SPS, the subsea manifold design shall meet the following functional requirements (all or some of the listed below):

.1 pipe hook-up, number of valves and flow control means shall ensure safety during gathering of the recovered well fluids and/or distribution of the production fluids and gases injected into wells;

.2 incorporate equipment to determine productive capacity of individual wells;

.3 allow for launching/reception of pigging and diagnose devices;

.4 incorporate equipment necessary for control, including emergency shutdown and current control over recovery and/or injection operations;

.5 ensure connection of discharge pipelines in such a way that the preventive maintenance operations performed to connect/disconnect the pipelines do not affect other connections;

.6 allow for performance of mounting/dismounting of the WHA without disconnection of the manifold piping and disturbance of connections between the manifold and WHA of other wells;

.7 ensure redundancy of lines in accordance with a particular SPS design;

.8 be in agreement with the principles of the barrier concept, adopted for a particular SPS (refer to [Section 3](#) of Part II "General Requirements for the Design of the Subsea Production Systems"), have a tightness and leakage control system;

.9 ensure emptying and pressure relief from the pipelines;

.10 minimize hydraulic losses;

.11 protect the equipment against corrosion.

2.1.7 The manifold as a whole and attachments of the pipes and valves shall be designed with consideration for the effects of loads due to slug flow of the fluids, other loads arising during operation of the system.

2.2 PIPELINES

2.2.1 All gathering pipelines all the way up to gathering main, including manifold shutoff valves, shutoff and safety valves shall be designed for maximum allowable pressure at the wellhead during operation.

2.2.2 Nominal values of working pressures for pipelines and equipment fitted thereon shall be taken in conformity with the requirements of recognized standards — refer to [1.1.5](#) of Part VI "Wellhead Equipment".

2.2.3 Flexible polymer-metal pipes with end fittings shall comply with the requirements of 3.7 and 4.6 of Part I "Subsea Pipelines" of the SP Rules, as well as 2.6 of the SP Guidelines.

2.2.4 Pipelines shall be arranged on the template or ground in such a way as to avoid stresses arising due to temperature, pressure, vibration, etc., effects. Consideration shall be given to possible vibration of the pipelines during operation. No resonance oscillations shall be set up in the system.

2.2.5 Diameter and bending radius of the pipelines shall allow for passage of pigging and diagnose devices where it is necessary proceeding from the operating conditions.

2.2.6 Pipeline assemblies shall be fitted with shutoff valves hooked up to emergency shutdown system. Valve locations are stipulated by the design.

2.2.7 Materials for manufacture of pipes and equipment fitted thereon shall be selected in accordance with recognized standards and [1.2](#) of Part II "General Requirements for the Design of the Subsea Production Systems".

2.2.8 In designing of the flowlines, the pressure, temperature, velocity, corrosion and erosive effects of fluid on the pipes and other factors shall be considered.

2.2.9 In case where fluid or gas contains sand, all pipeline bends shall be made with the use of tee-joints and welded blinds (or blank flanges), T-blinds or tee-joints - traps, or using elbows of large radius. Equipment to monitor presence of sand in the flowlines shall be provided.

2.2.10 To prevent sediments in the locations wherein the flow changes its direction, in way of the diameter increase, on long pipeline portions with variable profile, etc. the recommended minimum flow velocity in two-phase lines shall be stated in the project and taken into account during design stage.

2.2.11 The manifold piping, as a rule, shall be self-draining; no accumulation of fluid after shutdown and emptying is permitted.

2.3 SHUTOFF AND CONTROL VALVES

2.3.1 Shutoff and control valves fitted on the pipelines and provided with automatic or remote actuation shall have a gate position indicator clearly readable by ROV/diver. Valve actuators shall incorporate ability to shift the gates by ROV or manually.

2.3.2 Design and location of the manually operated valves shall give a clear indication of the gate position (open/ closed). In some cases (e.g. on cocks), position of manual controls (handles, levers, etc.) may be used as an indicator.

2.3.3 Manually actuated valves shall be closed by rotating the controls clockwise.

2.3.4 Nominal diameters and working pressures of valves shall be taken in compliance with recognized standards.

2.3.5 Coatings of the pipelines shall ensure protection against corrosion throughout the service life. Additionally, electrochemical or cathodic protection means may be provided.

2.3.6 Working pressure of the pipelines shall not be less than the working pressure on the pressure source side, unless structural or other measures are provided for overpressure protection on portions with lower working pressure.

2.3.7 For protection against overpressure on subsea portions, as a rule, the HIPPS shall be implemented.

2.3.8 Nominal diameters of valves shall correspond to the sizes of pipes on which the valves are fitted. If, proceeding from the operating conditions, no full-way valves are required (e.g. for pig launching and reception, etc.), valves with a different nominal diameter may be installed, depending on the results of the hydraulic calculations.

2.3.9 A non-return valve or bidirectional isolation valve shall be fitted on discharge pipeline to minimize possible back flow in case of wrong shifting or pipeline breaking. Provision shall be made for emptying of the discharge pipeline portion between wellhead and non-return valve with the aim to carry out periodic inspection of the valve performance. Possibility for unobstructed pigging shall be provided if required.

3 SUBSEA SYSTEMS FOR TREATMENT OF WELL FLUIDS

3.1 GENERAL

3.1.1 The subsea system for treatment of well fluids involves separation and supply of separated products by separate pipelines to FPU/FOP or directly to the user.

3.1.2 The subsea processing systems performs all operations for treatment of well fluids. In general, the following processes are used:

two-phase and three-phase separation;

pressure-boosting using multiphase pumps and gas compressors;

water injection into formation.

3.1.3 As a rule, two ways of utilization of separated formation water are employed: injection of water into the producing formation with the aim to maintain the reservoir pressure;

injection of formation water into the water-bearing formation situated above or below the producing formation.

3.1.4 After separation all the recovered well fluids shall be transported by separate subsea pipelines in one-phase state to FPU/FOP or directly to the user.

3.2 SEPARATION

3.2.1 General.

3.2.1.1 At the design stage, the performance of any separation system needs to be specified as accurately as possible to allow efficient design of the downstream processing facilities.

3.2.1.2 Subsea separation is typically used as a method to increase production rates, increase oil/gas recovery factor and overcome limitations of FLU/FOP facilities.

3.2.2 Hydrocarbon/water separation.

3.2.2.1 Subsea separation can be achieved either via a conventional gravity separator or by using two-stage separation, with the first stage involving gas-liquid separation and the second stage separating the water from the oil. Two-stage separators are usually based on cycloning or centrifugal designs.

3.2.2.2 In general, it is the oil-in-water content of the separated water that is the critical performance specification. The water-in-oil content of the separated hydrocarbons is typically less important, and the acceptable specification may be as high as 20 %.

3.2.3 Gas/liquid separation.

3.2.3.1 Subsea gas/liquid separation systems shall generally be developed in conjunction with a liquid pumping system. As a rule, two types of gas/liquid separation systems are used:

- gravity separation systems, which can be of either vertical or horizontal design;
- centrifugal separation systems, which allow the use of vessels smaller than gravity separators.

3.2.3.2 It is possible to locate the separators either near the wellhead or at the riser base. The optimum location depends on the production system characteristics and the primary reason for performing the separation. Typical options of the location:

- for long distance tie-backs, wellsite separation leads to reduction of pressure loss in the pipeline system. The value of pressure loss in the multiphase pipeline and reduction of such loss make it possible to decrease the pressure on the wellhead;

- for deepwater applications, with small elevation changes between the wellsite and the riser, and relatively short tie-back distances, separation at the riser base may be the preferred solution. Intervention of the separator can be performed from the FPU/FOP without the need for additional vessels.

3.2.4 Three-phase separation.

3.2.4.1 Three-phase subsea separation is also possible, however, significant challenges to obtaining reliable performance of such systems shall include:

- accurate and reliable measurement of the water, emulsion, oil, foam and gas interface levels within the separation vessel;

- provision of reliable variable-dosage chemical injection system;

- provision of high reliability subsea level control valves to control the flow rates of the various fluids from the separator;

- on-line measurement of the oil-in-water content of the produced water stream.

3.3 INJECTION AND PRESSURE-BOOSTING

3.3.1 General.

3.3.1.1 A typical subsea pumping unit shall consist of the following sub-systems:

- pump, including piping with valves;
- driver (electric or hydraulic), including connection fitting and power transmission;
- control and monitoring, including a control unit with power supply;
- electric motor lubrication and cooling systems.

3.3.1.2 When selecting the pumps, the presence of sand and various impurities in the pumped fluid shall be considered.

3.3.2 Multiphase pumps.

3.3.2.1 Multiphase pumps being part of the SPS are generally classified into the following two categories:

hydrodynamic pumps, which work on the principle of transforming kinetic energy into static energy (head), e.g. helicon-axial pumps;

positive displacement pumps, twin-screw, piston and progressive cavity pumps.

3.3.2.2 For deepwater developments with short tieback distance, an acceptable alternative to locating the pump can be to locate it at the riser base adjacent to the separation facility, so that intervention for repair and maintenance can be performed from the FPU/FOP.

3.3.3 Wet gas compressors.

3.3.3.1 Wet gas compressors are designed for the same basic services as multiphase pumps, but with higher gas volume fractions. The allowable liquid-in-gas content downstream of the compressor is specified by the compressor manufacturer.

3.3.3.2 The wet gas transportation system shall operate without risk of hydrate build-up or clogging.

3.3.3.3 The compressor(s) shall be so designed as to be capable of operating reliably over the entire range of flow rates and composition of the pumped gas.

3.3.4 Water disposal and injection.

3.3.4.1 The requirements for successful produced water injection are:

chemical compatibility between the injection water and the formation fluid, such that the scale does not form;

monitoring and control of oil-in-water and solids content levels to suit the requirements of the national normative documents.

3.3.4.2 Especially drilled wells are used for injection of produced water.

3.3.5 Monitoring and control of subsea treatment systems.

3.3.5.1 In addition to conventional pressure and temperature-monitoring, additional process variables that may need to be monitored include:

fluid flow rates, either single-phase or multiphase;

the position of the oil, water, emulsion interfaces in subsea separators;

oil-in-water content of separated water (an accurate on-line monitor is required to confirm that the water quality is acceptable for re-injection into a suitable downhole formation);

water cut of the separated oil.

3.3.5.2 It is preferable to directly monitor the following parameters:

pump suction and discharge pressure and temperature;

pump/motor speed, shaft run-out and bearing temperature, axial and radial vibration of rotating components, electrical power supply characteristics, e. g. driving current and its harmonics;

correct functioning of critical components, such as level detectors, level control valves, the oil-in-water monitors, the chemical-dosing system, fluid barrier systems, etc;

sand production/buildup in process vessels (for fields where significant sand production is anticipated, a sand removal mechanism is required).

3.3.5.3 Methods for performing all the required parameters monitoring need to be incorporated into the overall system design from the outset. Electromagnetic compatibility of the systems shall be considered.

3.4 WELL FLUID METERING EQUIPMENT

3.4.1 Materials shall be selected in accordance with the requirements of [1.2](#) of Part II "General Requirements for the Design of the Subsea Production Systems" and recognized standards.

3.4.2 For designing of the system, due consideration shall be given to design loads in accordance with [Section 2](#) of Part III "Operational Condition and Design Loads".

3.4.3 The metering instruments shall be checked by a competent body.

3.4.4 Acceptance tests of the metering system is recommended to be conducted in accordance with Section 11 of ISO 13628-6.

PART VIII. FIELD SUBSEA PIPELINES AND RISERS

1 GENERAL

1.1 Field subsea pipelines and production risers being part of the SPS shall be designed in conformity with the conditions of oil-gas field development on sea shelf.

1.2 Field subsea pipelines and production risers being part of the SPS shall meet the requirements of Part I "Subsea Pipelines" of the Register SP Rules as far as applicable.

2 SUBSEA PIG LAUNCHERS AND/OR RECEIVERS

2.1 GENERAL

2.1.1 Pig launchers/receivers shall ensure launching and/or receiving of cleaning, intelligent, separation and sealing pigs in the flow of the conveyed working medium.

2.1.2 The working medium, temperature and pressure of working medium for pig launchers/receivers shall be indicated in the technical documentation.

2.1.3 The working pressure of the pig launcher/receiver shall be selected based on the technical parameters of the subsea pipeline to be connected.

2.1.4 In addition to the requirements of this Chapter, pig launchers/receivers shall comply with the applicable requirements in 3.6 of Part V "Systems and Piping" of the OGE Rules.

2.1.5 The requirements for seismic resistance of the pig launchers/receivers shall be as per [2.1.7](#) of Part III "Operational Conditions and Design Loads".

2.1.6 The external loads shall be calculated in accordance with Part I "Subsea Pipelines" of the SP Rules and GOST R 54382.

2.1.7 Structural protection shall be provided to prevent mechanical damage to the hydraulic control lines of the pig launchers/receivers.

2.2 DESIGN REQUIREMENTS

2.2.1 The internal design pressure of the pig launchers/receivers shall be assumed to be equal to at least the design pressure of the pipeline. When using the pig receiver/launcher for the test pressure build up in the pipeline, the working pressure of the pig receiver/launcher shall be taken equal to the test pressure of the pipeline.

2.2.2 The design of the pig launchers/receivers shall take account of the loads that occur during installation, operation, maintenance, decommissioning, during lifting operations in workshop (on shore), when moving from ship to ship (at sea) and passing the splash zone. The calculations of the above loads shall be submitted to the Register for review as part of the technical documentation on pig launchers/receivers.

2.2.3 The design of the pig launchers/receivers shall enable inserting of cleaning, intelligent, separation and sealing pigs of the specified sizes and types.

2.2.4 All blank and enclosed load-bearing structural components of pig launchers/receivers made of shaped and round pipes, as well as metal sheets, shall have through holes to reduce hydraulic resistance in submersing pig launchers/receivers into water.

2.2.5 The design of the pig launcher/receiver support shall enable axial and angular alignment to achieve acceptable values ensuring the operability of the means used for connection of the pig launcher/receiver to the SPS and SP equipment.

2.2.6 The pig launcher/receiver shall be designed with end terminations for connecting quick-action couplings using ROV.

2.2.7 The welding and weld quality are subject to the requirements in [7.6](#) of Part I "General Regulations for Technical Supervision".

2.2.8 The design characteristics of the supports of pig launchers/receivers shall be established in the technical documentation. The supports shall transmit loads from the pig launcher/receiver to the foundations, the requirements for which are given in [Part IV](#) "Foundations". The number and technical parameters of the supports shall be determined taking into account the allowable loads.

2.2.9 The pig launchers/receivers shall be designed with special devices to ensure ROV operation in accordance with the requirements of ISO 13628-8.

2.2.10 The design of the control panel shall allow ROV access to control the shutoff valves of the pig launcher/receiver piping, connect the quick-action couplings with the working medium hoses and carry out leak tests of connections between the quick-action couplings and pig launchers/receivers.

2.2.11 Controls for shutoff valves with position indicators ("open-close"), connectors for quick-action couplings, connectors for hydraulic plugs and sockets for temporary storage of hydraulic line protection plugs shall be brought out to the control panel of the pig launcher/receiver.

2.2.12 Shutoff valves shall be installed on the piping of the pig launcher/receiver in accordance with the applicable requirements of GOST R 59305. Connection shall be carried out by welding.

2.2.13 The ROV tool socket for controlling shutoff valves shall be made according to ISO 13628-8.

2.2.14 The pig launcher/receiver shall be designed with nozzles for filling, draining and testing the tightness of the end closure.

2.2.15 The design of the end closure shall include a pig stop to ensure that the required volume inside the pig launcher/receiver barrel is available for reception of cuttings. The required volume for reception of cuttings shall be calculated and specified in the technical documentation for the pig launcher/receiver.

2.2.16 Protective plugs and plugs for quick-action couplings shall be designed to enable installation and removal using ROV in accordance with ISO 13628-8.

2.2.17 It is recommended that the pig signaller can be installed and removed using ROV.

2.2.18 If a digital display is used for pressure and temperature measurement devices, its specifications shall ensure that ROV cameras provide a good quality video image, including in low water clarity and light-level conditions. It is recommended that the pressure and temperature measuring and recording device be equipped with an internal digital data storage for recording sensor readings and a connector for accessing the data.

2.2.19 The location and fixing of the pressure and temperature measuring and recording device on the pig launcher/receiver shall ensure that it is protected from accidental contact with ROV and rigging equipment.

2.2.20 The internal diameter of the pig launcher/receiver shall be the same as the internal diameter of the pipeline adjacent to the pig launcher/receiver, and shall have no structural obstructions that could interfere with the passage of pigs.

2.2.21 The longitudinal weld of the pig launcher/receiver shall not coincide with the branch opening, and the minimum distance between them shall be 150 mm.

2.2.22 A thermal relief valve shall be fitted in pig launchers/receivers which are used for liquid media or media containing liquid phase.

2.2.23 The requirements for corrosion protection of the pig launcher/receiver equipment shall be in accordance with [1.3](#) of Part II "General Requirements for Design of the Subsea Production Systems".

2.2.24 Coating materials for stainless steel components shall not contain metallic zinc in the primer.

2.2.25 The fasteners shall not be cadmium plated.

2.3 MATERIALS

2.3.1 When selecting materials for the manufacture of component parts of pig launchers/receivers, the requirements and recommendations of GOST R 59305 shall be taken into account.

2.3.2 Materials and welded joints of the pig launcher/receiver components under internal pressure shall be subjected to mechanical tests in accordance with 4.2.3.6 of Part I "Subsea Pipelines" of the SP Rules, unless otherwise specified in the documentation approved by the Register. The requirements for the materials of pig launchers/receivers may comply with national and/or international standards providing approximate equivalence of the requirements in comparison with the Register requirements for the pipes of the subsea pipeline to be connected (including the requirements for corrosion resistance), and the RS-approved technical documentation.

2.3.3 The actual value of the yield stress for the pig launcher/receiver components, which are under electrochemical protection, shall not exceed 950 MPa.

2.3.4 The use of titanium and its alloys for electrochemically protected components is not permitted.

2.3.5 Corrosion protection in accordance with Section 7 of Part I "Subsea Pipelines" of the SP Rules shall be provided for the surfaces of the pig launcher/receiver components that are in contact with the formation fluid. Areas of contact sealing surfaces made of low-alloy steels are recommended to be protected by anti-corrosion hard-facing of XH75MБТЮ nickel alloy or its equivalent.

2.3.6 The hardness of the metal seal material shall be lower than the hardness of the surfaces in contact with the metal seal.

2.3.7 The metal sealing rings for joint elements in contact with the formation fluid and seawater shall be made from corrosion-resistant alloys.

2.3.8 Non-metallic materials of the pig launcher/receiver components shall be resistant to the media with which they come into contact throughout their service life, taking into account the operating temperature range.

2.3.9 Non-metallic materials for seals in contact with the formation fluid shall be resistant to rapid depressurization and ageing in hydrocarbon service.

2.3.10 Non-metallic materials for seals shall be resistant to all reagents injected into the system.

2.3.11 The material of sacrificial anodes for electrochemical protection shall be selected according to the operating conditions as per [1.3.6](#) of Part II "General Requirements for Design of the Subsea Production Systems".

2.4 REQUIREMENTS FOR TESTS, INSPECTIONS AND INSTALLATION

2.4.1 To check the quality of pig launchers/receivers, they shall be tested in accordance with the manufacturer's test programme approved by the RS.

2.4.2 A mixture consisting of 60 % of water and 40 % of mono-ethylene glycol is recommended for hydraulic testing of pig launchers/receivers. Condensate formation on the surface of the walls of the pig launcher/receiver is not permitted. Test medium of a different composition may be used, provided it is neutral or comprises an appropriate corrosion inhibitor for metallic and non-metallic materials in the pig launcher/receiver.

2.4.3 The pressure during hydraulic testing shall be monitored using two calibrated pressure gauges. Both pressure gauges shall be of the same type, range of measurement, accuracy class and scale value. Accuracy class of the pressure gauges is up to 1,0 over the entire measuring range.

2.4.4 Overall and connection dimensions shall be checked after hydraulic strength and leak tests as well as after final treatment of the pig launcher/receiver barrel before application of the corrosion protection coating.

2.4.5 Checking the internal diameter of the pig launcher/receiver barrel shall be carried out by pulling a drift diameter gauge with a diameter equal to at least 97 % of the internal diameter of the pig launcher/receiver. An electronic gauging pig may be used to check the internal diameter.

2.4.6 The hardness of the gauge material shall be less than the specified hardness of the pig launcher/receiver barrel.

2.4.7 The pig launcher/receiver shall be considered to have passed the test if the drift diameter gauge does not jam during the check and there is no mechanical damage on the surface of the drift diameter gauge.

2.4.8 The quality assessment of the welds of pig launchers/receivers shall be carried out taking into account the requirements in [7.6](#) of Part I "General Regulations for Technical Supervision".

2.4.9 Welding operations shall be carried out by welders who have been certified in accordance with the rules for certification of welders and welding engineers according to the requirements set out in [7.6](#) of Part I "General Regulations for Technical Supervision".

2.4.10 To confirm the electrochemical characteristics of the alloy, the sacrificial anodes shall undergo certification tests in accordance with 7.4.3 of Part I "Subsea Pipelines" of the SP Rules.

2.4.11 The operability checks of the components of pig launchers/receivers shall be carried out as part of the test programme approved by the Register, drawn up taking into account the manufacturer's recommendations.

2.4.12 Reviewing the operability of the components of pig launchers/receivers depends on the design features of the components and comprises the checking of:

operability of the pig signaller and other instruments;

alignment means of pig launchers/receivers;

operability of shutoff valves;

kicking of pigs;

operability of the connection devices between the pig launcher/receiver and the matching SPS component.

2.4.13 The unprotected components of the pig launcher/receiver shall withstand, without damage, a collision with ROV at a speed of up to 1,5 m/s. The maximum impact energy shall be calculated from the impact of the heavy duty work class ROV.

2.4.14 The design documentation developer shall carry out a simulation of the sequential ROV operations to access the pig launcher/receiver components.

2.4.15 Tightness testing of end closures shall be carried out in accordance with the manufacturer's recommendations.

2.4.16 Hydrostatic testing for leak and strength shall be conducted before the corrosion protection coating is applied.

2.4.17 The test pressure for hydrostatic strength tests shall be taken in accordance with 8.6.4 of Part I "Subsea Pipelines" of the SP Rules. The pig launcher/receiver shall be held under test pressure for at least 60 min.

2.4.18 After holding under test pressure, a leak test shall be conducted. The pressure value for leak testing shall be taken in accordance with 8.6.5 of Part I "Subsea Pipelines" of the SP Rules. The holding time during leak tests shall be sufficient to inspect the outer surface of the pig launcher/receiver, all its split-type joints and welds, but not less than 30 min.

2.4.19 The pig launcher/receiver is considered as having passed the leak test if, under normal conditions, no visible leaks were detected during the holding under pressure. Decrease in pressure during the holding periods shall be less than 1 % of the test pressure.

2.4.20 The bearing capacity of the pig launcher/receiver structures shall be verified by strength calculation and/or testing.

2.4.21 Vibration testing of individual components of pig launchers/receivers shall be carried out in accordance with the applicable requirements of GOST 30546.2.

2.4.22 The installation and mounting of pig launchers/receivers shall be carried out in accordance with the pig launcher/receiver operating manual and installation instruction developed by the manufacturer. The installation shall be conducted by a specialised organisation recognised by the Register in accordance with [7.5](#) of Part I "General Regulations for Technical Supervision".

2.4.23 It shall be possible to monitor the installation and mounting of the pig launcher/receiver under water using ROV.

2.4.24 In case of corrosion protection coating damage resulting from transportation of the pig launcher/receiver, loading/unloading and construction and installation works, it is allowed to repair the corrosion protection coating. Corrosion protection coating repairs shall be performed by an organisation recognised by the Register according to [7.5](#) of Part I "General Regulations for Technical Supervision", manufacturer's recommendations and operational procedure for corrosion protection coating repairs agreed with the Register.

2.4.25 The pig launcher/receiver shall be examined by ROV after installation, prior to commissioning, by RS-recognised organizations in accordance with [7.5](#) of Part I "General Regulations for Technical Supervision". The scope, methods and frequency of in-service examinations of pig launchers/receivers shall be determined in accordance with [9.3](#) of Part I "General Regulations for Technical Supervision".

2.4.26 When carrying out in-line inspection using pig launchers/receivers, the applicable requirements of 4.1.2.3 of the Guidelines on Technical Supervision during Construction and Operation of Subsea Pipelines shall be followed.

3 PIPELINE END MANIFOLD (PLEM)

3.1 The PLEM shall ensure that the fluid flow through the subsea pipeline is shut off and/or redistributed to other subsea piping systems and SPS, including riser systems, depending on the operational need stipulated by the design.

3.2 The transported medium, its temperature and working pressure for PLEM shall be indicated in the technical documentation. The working and design pressures of PLEM shall be specified based on the technical parameters of the subsea pipeline to be connected, the design pressure of PLEM shall be assumed to be equal to at least the design pressure of the pipeline.

3.3 The design of the PLEM and its seabed base (foundation) shall take account of the loads that occur during installation, operation, maintenance, decommissioning, during lifting operations in workshop (on shore), when moving from ship to ship (at sea) and passing the splash zone. The calculations of the above loads shall be submitted to the Register for review as part of the technical documentation on PLEM.

3.4 The external loads shall be calculated in accordance with Part I "Subsea Pipelines" of the SP Rules and GOST R 54382. The requirements for seismic resistance of PLEM shall be as per [2.1.7](#) of Part III "Operational Conditions and Design Loads".

3.5 Protection of PLEM equipment shall be provided where necessary. The protection shall be designed in compliance with the requirements of [Part V](#) "Protective Structures".

3.6 The design of the PLEM seabed base (foundation) shall meet the requirements of [Part IV](#) "Foundations".

3.7 The welding and weld quality requirements shall comply with [7.6](#) of Part I "General Regulations for Technical Supervision".

3.8 On agreement with the customer, the PLEM shall be designed with special devices to ensure ROV operation in accordance with the requirements of ISO 13628-8.

3.9 The requirements for corrosion protection of the PLEM and its seabed base (foundation) shall be in accordance with [1.3](#) of Part II "General Requirements for Design of the Subsea Production Systems".

3.10 The material of sacrificial anodes for electrochemical protection shall be selected according to the operating conditions as per [1.3.6](#) of Part II "General Requirements for Design of the Subsea Production Systems".

3.11 To confirm the electrochemical characteristics of the alloy, the sacrificial anodes shall undergo certification tests in accordance with 7.4.3 of Part I "Subsea Pipelines" of the SP Rules.

3.12 The design of PLEM shall enable passage of cleaning, intelligent, separation and sealing pigs of the specified sizes and types.

3.13 The valves installed on the PLEM, depending on the purpose, shall comply with: ISO 13628-4 for cluster manifolds;

ISO 14723 for valves of subsea pipeline systems, including offloading piping.

The applicable requirements in [2.3](#) of Part VII "Systems for Gathering and Treatment of Well Fluids" shall also be taken into account.

3.14 When selecting materials for the manufacture of component parts of PLEM, the requirements and recommendations of GOST R 59305 and ISO 13628-15 shall be taken into account.

3.15 Materials and welded joints of the PLEM components under internal pressure shall be subjected to mechanical tests in accordance with 4.2.3.6 of Part I "Subsea Pipelines" of the SP Rules, unless otherwise specified in the documentation approved by the Register.

3.16 To check its quality, the PLEM shall be tested in accordance with the manufacturer's test programme approved by the RS.

4 PIPELINE END TERMINATIONS (PLET) AND IN-LINE TEES (ILT)

4.1 Pipeline end termination (PLET) is a termination component of a subsea pipeline, which typically comprises the following:

- seabed base;
- protective structure;
- main line with shutoff valves and the pipeline connector;
- branch line with shutoff valves and the pipeline connector;
- controls for ROV;
- set of pressure caps.

4.2 In-line tee (ILT) is a component of a subsea pipeline with shutoff valves on the branch line providing connection between the main line and other pipeline. Typically, ILT comprises the following:

- seabed base;
- protective structure;
- branch line with shutoff valves and the pipeline connector;
- controls for ROV;
- set of pressure caps.

4.3 PLET and ILT shall both comply with the requirements of [3.2 — 3.16](#), Section 3 of this Part of the Rules.

4.4 The set of pressure caps is used to protect interior of the pipeline and connectors against damage and contamination.

4.4.1 Low-pressure cap (LP cap) for PLET and ILT shall protect the inside of the pipe at ambient pressure, including at water pressure at the installation depth, until the planned commissioning of the equipment.

4.4.2 High-pressure cap (HP cap) for PLET and ILT shall protect and seal the inside of the pipe of an SPS component filled with weld fluid or process fluid, when operating at a working pressure at the operating depth.

4.4.3 The debris cap (cap against mud) for PLET and ILT shall protect a sealing profile of the pipeline connector and prevent the ingress of contamination into the pipeline interior and the connector sealing area during underwater installation and maintenance after removal of a HP/LP cap .

4.4.4 The test caps for PLET and ILT shall withstand pressure during testing.

4.4.5 Both the HP and LP caps for PLET and ILT shall be fitted with a sealing as well as the handling and mounting rails for ROV.

4.4.6 Clamping mechanisms of caps for PLET and ILT shall be fitted with locking devices or lock screws against inadvertent disengagement.

4.5 Installation operations of PLET and ILT shall be designed based on the requirements and recommendations for lifting devices and non-pressurized structural elements specified in GOST R 59305 (ISO 13628-1:2005) (Appendix K).

4.5.1 The design shall contain the list of input data, the list of reference criteria, description of the design scenarios, description of calculation procedure and software application, the calculation results and conclusions therefrom. The input data shall include weight and size characteristics of PLET and ILT, parameters of a pipeline to be connected, hydro-meteorological conditions at the area of the equipment installation, seaworthiness properties of the vessels involved, features of a typical crane equipment as well as the installation procedures.

4.5.2 The list of reference criteria shall contain information on the monitored parameters of equipment and pipeline condition according to the normative and/or design documentation allowing unambiguously assess the possibility to carry out planned operations as per the design results.

4.5.3 The description of the design scenarios shall contain information on the combination of various input data and reference criteria, which are estimated for the planned offshore operations. These scenarios shall consider deviation in seaworthiness properties of the vessel involved depending on the direction of loads due to environmental impact.

4.5.4 The calculation procedure shall contain information on mathematical dependencies, coefficients and normative documentation as well as the description of software and mathematical model applied.

4.5.5 The calculation results shall contain the condition parameters of equipment and a pipeline to be connected for each design scenario, and a reference criterion with a relevant result.

4.5.6 Conclusions from the calculation results shall contain a statement whether it is possible to carry out the planned installation operations and a description of limitations for the work.

4.6 The main line for PLET and ILT designed for a pig transfer shall meet the following requirements:

- the inner diameter shall be of the full-passage type and not prevent pig from passing in both directions;

- the pipeline bend radius shall not be less than the minimum allowed;

- suspended solids formed when cleaning the deposits shall not accumulate inside the pipeline outlets being cleaned (outlets of the branch line shall be located above the main line axis);

- protective grills are not allowed to protrude inside;

- branch lines installed in series, shutoff valves and outlets should be separated from each other by straight pipe sections having a length of not less than three inner diameters of the pipeline;

- in sections where a pig is used, components of PLET and ILT should have the same inner diameter with a pipeline to be connected.

4.7 Edges of the outlets for PLET and ILT to be welded to a pipeline shall be prepared for welding in accordance with the requirements of Section 5, Part I of the SP Rules.

4.8 Shutoff valves for PLET and ILT shall be connected to a pipeline by welding joint.

4.9 Connectors of the main and branch lines for PLET and ILT shall have guiding elements to ensure precise positioning of the mating equipment during connection.

4.10 When connecting to a pipeline, the connection system for PLET and ILT shall compensate both axial and angular deviation by means of a complete alignment or, in the case of an axial and/or angular deviation, by ensuring a leakproof connection.

4.11 PLET and ILT shall be both designed so to allow for inspection, maintenance and repair by means of ROV all throughout the service life.

4.12 The coupling sleeves for PLET and ILT shall be designed so that the metal seal can be replaced.

4.13 The design of PLET shall allow for installation and retrieval of pig launcher/receiver, where necessary.

PART IX. UMBILICALS

1 GENERAL

1.1 The umbilicals shall be capable of transporting working fluids, power supply, control and monitoring signals.

1.2 Power supply and transmission of signals can be accomplished through separate cable conductors or control signals can be transmitted by cable conductors of power supply lines, thus reducing the total number of conductors in the umbilical.

1.3 Hydraulic power and hydraulic control signals are transmitted by separate channels of the umbilical.

1.4 All the above-mentioned lines may be structurally grouped together in the same umbilical, but may also be separately mounted.

1.5 Sheaths of the umbilicals are made of polymeric materials or metal throughout the design length, without joint elements.

1.6 The umbilical sheaths shall not interact with transported fluids and shall be resistant to mechanical loads during manufacture, storage, installation and operation.

1.7 Because of corrosion and possible fatigue damages, the umbilicals in metal sheaths require special consideration by the Register in order to specify then-service life. In specific cases, for transportation of well fluids, only the umbilicals with steel sheaths are used.

1.8 The umbilical, and its constituent components, shall have the following characteristics:

.1 capable of withstanding all design loads and load combinations and perform its functions for the specified design life;

.2 materials shall be compatible with the environment to which they are exposed and be in conformity with the corrosion control and compatibility requirements;

.3 electric cable shall be capable of transmitting power and signals with the required characteristics;

.4 optical fibre cables shall be capable of transmitting signals at the required wavelengths within the attenuation requirements;

.5 hoses and/or tubes shall be capable of transmitting fluids at the required flow rate, pressure, temperature and cleanliness levels;

.6 capable of venting, in a controlled manner, if permeation through components can occur;

.7 capable of being recovered and reinstated as defined in the manufacturer's specification approved by the Register.

1.9 In designing of the umbilicals, the functional loads shall be taken into account: loads due to weight and buoyancy of the umbilical, its contents and attachments, both temporary and permanent;

pressure within hoses and tubes;

thermal expansion and contraction loads;

testing pressure during commissioning;

reactions and loads from supports and protective structures;

temporary installation/laying or maintenance loads;

loads due to rigid/flexible pipe crossings, or spars;

loads due to positioning tolerances during installation/laying;

loads due to interaction of individual umbilical components, in particular, metal sheaths;

loads from inspection and maintenance tools.

1.10 The umbilicals shall be manufactured according to the Register-approved technical documentation elaborated on the basis of recognized standards.

2 TECHNICAL REQUIREMENTS

2.1 GENERAL

2.1.1 Technical documentation for the umbilicals, to be submitted to the Register for approval shall include, as a rule, the following:

description of the theoretical basis, including calculation procedures and methods of evaluating the umbilical design parameters and the criteria to be satisfied in order to meet the functional requirements specified in [1.8](#);

the design life assessment methodology taking into account the fatigue strength under acting design loads;

determination of the stress concentration factors to account for the geometry of metallic structural components, including stress concentrations at and within the umbilical termination head interface, contact with clamped accessories and rigid surfaces, manufacturing tolerances, and load-induced gaps;

specification of the manufacturing tolerances which influence on the limiting allowable structural capacity.

2.1.2 The umbilical design shall be approved by the Register (refer to the SPS Nomenclature — [Table 6.1](#) of Part I "General Regulations for Technical Supervision") and shall account for the effects of wear, corrosion, manufacturing processes, installation loads, dimensional changes, creep and ageing (due to mechanical, chemical and thermal degradation in all layers).

2.1.3 If the umbilical design is outside the envelope of previously validated designs, then the manufacturer shall perform prototype tests to verify the design methodology. The prototype tests involving the Register's representative shall validate fitness-for-purpose for those design parameters which are outside the previously validated envelope.

2.1.4 The functional requirements for the umbilical shall be set forth by the customer and approved by the Register during examination of technical documentation.

2.1.5 The manufacturer shall calculate the useful life of the umbilical considering the actual operating conditions.

2.1.6 The umbilical design shall account for all combinations of loads acting thereon taking into account of their duration, including effects of environment and seabed soil ([refer to 1.9](#)).

2.1.7 The umbilical design loads, minimum bend radius and allowable crushing load shall be within the allowable limits established in the SPS installation project and approved by the Register.

2.1.8 In the process of installation of the umbilical the following parameters shall be monitored:

in the variation of tension and bend radius along the installed umbilical;

variation of tension and bend radius as a function of time;

maximum tension and minimum bend radius points.

2.1.9 When considering the fatigue strength, vibration of the umbilical at various points due to the effects of waves, current, pressure fluctuations and other factors shall be taken into account. As a rule, a typical safety factor for fatigue loading equal to 10 has been found suitable.

2.1.10 The metallic and non-metallic materials used in the umbilical shall ensure normal performance of the umbilical throughout its design life, and this shall be confirmed by calculations made according to the standards recognized by the Register.

2.1.11 When making calculations, the following factors shall be considered:

.1 deterioration of material properties throughout the service life;

.2 susceptibility of metallic elements to corrosion, cathodic attack and delamination of bonded elements;

.3 seabed stability, including the need for additional ballasting and impact on other installation activities;

.4 fatigue of armour wires, bend stiffeners, polymers and pressure-retaining components;

.5 minimum breaking loads;

.6 effects of environmental conditions (for example, UV radiation, temperature, ozone and long-term exposure to seawater and transported fluids);

.7 cumulative strain of conductors, metallic tubes and cables throughout the manufacture, handling and installation processes;

.8 strain of optical fibres.

2.1.12 Unless otherwise agreed with the Register, the umbilical and its constituent components and materials shall be capable of operating within the temperature range of -15°C to $+40^{\circ}\text{C}$. The temperature during storage may differ from the specified one, but the umbilicals shall maintain their parameters when the temperature is brought to the specified values.

2.1.13 The minimum radius to which the umbilical can be bent for storage and service shall be determined. The minimum bend radius of the electrical cables, hoses, tubes and optical fibre cables shall be as stated in the manufacturer's written specification.

2.1.14 The umbilical shall be designed to be fatigue-resistant for the designed design life, with an adequate safety factor specified in [2.1.9](#).

2.1.15 The umbilical shall be designed to be sufficiently stable when laid on the seabed to meet the requirements of the recognized standards and 6.1.7 of Part I "Subsea Pipelines" of the SP Rules.

3 MANUFACTURE AND TESTING OF UMBILICAL COMPONENTS

3.1 GENERAL

3.1.1 The umbilical components shall be designed and manufactured in conformity with the recognized standards. Conformity shall be confirmed by examination of technical documentation, surveys and acceptance tests involving the RS representative. The test programs shall be approved by the Register.

3.1.2 The factory acceptance tests shall be conducted for umbilical termination heads and ancillary equipment.

3.1.3 The requirements for the electrical and signal cables being part of the umbilical are set out in [Part X](#) "Electrical Equipment".

3.1.4 Material used for the manufacture of the umbilicals shall be suitable for long-term operation in seawater environment.

3.2 HOSES

3.2.1 It is recommended that the nominal bore and design working pressure be chosen to meet the requirements of Annex C to ISO 13628-5.

3.2.2 Tolerances on nominal bore of the hose and liner wall thickness shall not exceed the values given in [Table 3.2.2-1](#). The inside and outside diameters of the hose shall be concentric within the limits in [Table 3.2.2-2](#).

Table 3.2.2-1

Nominal bore		Tolerance, %	Liner wall thickness, <i>t</i>	
mm	in		mm	in
6,0 – 10,0	0,233 – 0,394	+5,0 –3,0	±0,2	0,0079
10,1 – 20,0	0,395 – 0,787	+3,0 –2,0	±0,2	0,0079
20,1 – 38,1	0,788 – 1,5	+2,0 –1,5	±0,25	0,0098

Table 3.2.2-2

Nominal bore		Concentricity	
mm	in	mm	in
up to 25,4	1,0	1,0	0,040
above 25,4	1,0	1,5	0,060

3.2.3 The completed hose outside diameter shall be within ±4% of the value specified in the manufacturer written specification.

3.2.4 If the hose liner is specifically designed to withstand hydrostatic pressure, the wall thickness and concentricity tolerances may differ from those given in [Table 3.2.2-2](#). Such deviations shall be consistent with the manufacturer's specification and agreed with the Register.

3.3 HOSE CONSTRUCTION

3.3.1 General.

3.3.1.1 The hose shall comprise three component parts: the liner, the reinforcement and the sheath.

3.3.2 Hose liner.

3.3.2.1 The liner shall be a continuous, seamless, circular and concentric extrusion and shall be compatible with the intended service fluids.

3.3.2.2 Multi-layer liners may be acceptable if application requirements cannot be satisfied by a single-layer construction as to its strength. For instance, in situations where there are high external pressures, then the use of an internal reinforcing layer (carcass) may be incorporated.

3.3.2.3 No degradation of the liner material is allowed while interacting with the media transported.

3.3.3 The reinforcement shall comprise one or more layers of synthetic fibre, applied around the liner.

3.3.4 Hose sheath.

3.3.4.1 The sheath shall comprise a continuous, seamless, circular extrusion, manufactured from polymer thermoplastic material incorporating protection against ozone and UV radiation.

3.3.4.2 The sheath material shall be compatible with the interstitial filler material and the sheathing material of other services within the umbilical throughout its design life.

3.3.4.3 The sheath shall be designed to protect the reinforcement and liner from abrasion, erosion and mechanical damage.

3.4 TERMINATION INTERFACE

3.4.1 The long-term sealing and retention of umbilical termination heads and /or end fittings shall not be impeded by the hose materials of construction. All materials used shall be suitable for long-term immersion in seawater and shall be in accordance with the manufacturer's specification.

3.4.2 If hose joints are crimped or swaged onto the outer sheath of the umbilical, the permeated fluids from the hose shall not degrade the sheath material, resulting in the end fitting leaking or detaching from the hose.

3.4.3 The coupling used to join two hose lengths within an umbilical shall be of the one-piece unthreaded type.

3.4.4 The coupling used to join lengths within a rigid umbilical joint might be of the threaded type and/or a one-piece design type.

3.4.5 End fittings or couplings in rigid joints shall either be protected by a water-blocking barrier, or have the facility for linking to a cathodic protection system.

3.4.6 If there is a risk of an end fitting or coupling nut unscrewing as a result of vibration, then an appropriate interlock feature shall be included to prevent rotation of the nut.

3.5 CROSS-SECTIONAL ARRANGEMENT

3.5.1 General.

3.5.1.1 The umbilical construction shall comprise:

- a bundle of electrical cables, optical fibre cables and/ or hoses;
- an inner sheath to provide mechanical protection of the bundle;
- armouring layers on inner sheath;
- an outer sealing sheath.

3.5.1.2 The umbilical shall be designed to meet the functional and design requirements of these Rules and the requirements for the mechanical properties of the manufacturer's specification. The following shall be taken into account:

- the cross-section shall be as compact as possible;
- the cross-section shall be as symmetrical about the centerline, as possible.

3.5.1.3 Electric cables, optical fibre cables, hoses shall be placed concentrically in respect to the basic umbilical components. Arrangements with electric cables around the outer sheath are permissible. In this case, the design of the electric cables shall take into account the additional loadings which may be imposed on the cables.

3.5.1.4 If fillers are used in the interstices of the umbilical, the filler material shall be selected with consideration of the crushing forces on the bundle due to umbilical manufacture, installation and service.

3.5.1.5 For deep-water installations, the cross-sectional arrangement shall take account of the requirements for the umbilicals/pipelines laid on the seabed, according to which the external crushing forces imposed during installation shall not damage the umbilical components.

3.5.2 Inner sheath.

3.5.2.1 As a rule, the inner sheath shall comprise a seamless, polymer (thermoplast) extrusion. For static applications, a layer of helically applied synthetic fibre roving may be used.

3.5.2.2 The inner sheath shall be of sufficient thickness to ensure proper distribution of radial compression between the armour wire and the bundle.

3.5.3 Armouring.

3.5.3.1 Umbilicals which contain electrical conductors and/or optical fibres shall generally be armoured. For umbilicals which allow for dynamic application of external loads, in particular, torques, the armouring shall consist of one or more axial contra-helically applied layers of steel armour wires/strips oriented about the generatrix, as a rule, at an angle from 20° to 55°.

3.5.3.2 The armour wires/strips shall be applied under uniform tension over the entire length. For multilayer armour, additional layers shall be applied in the opposite direction to the adjacent layers.

3.5.3.3 The requirements for the strength calculations of the umbilical shall be in compliance with 3.7 of Part I "Subsea Pipelines" of the SP Rules and the standards recognized by the Register.

3.5.4 Outer sheath.

3.5.4.1 As a rule, the outer sheaths shall comprise of a seamless polymer (thermoplast) extrusion.

3.5.4.2 To provide visual indication of position of the umbilical in the outer sheath, a high-visibility line of contrasting colour shall be applied along the umbilical length.

3.6 IDENTIFICATION

3.6.1 At least the following information shall be marked along the complete length of an umbilical, on the external sheath at regular intervals not exceeding 1 m:

- manufacturer;
- batch number;
- nominal bore size;
- working pressure;
- unique component reference.

3.6.2 Each 100 m of umbilical lengths shall be sequentially marked on the outer sheath, with the exception of the first and last 100 m, which shall be sequentially marked in 10 m increments. The marks shall be durable throughout storage, load-out and installation of the umbilical and legible to divers or underwater video cameras.

4 UMBILICAL TERMINATION HEADS AND ANCILLARY EQUIPMENT

4.1 GENERAL

4.1.1 The underwater structurally designed part(s) of an umbilical shall end in a UTH for attachment to the SUDU, SUT, manifold, etc., to be mated underwater, including use of the ROV.

4.1.2 The UTH shall provide:
a structural interface between the umbilical and the support structure of the termination head;

a structural interface between the umbilical and bend limiter/bend stiffener.

4.1.3 Umbilical termination heads interfaces with the umbilical components are a critical area and shall be especially addressed during the design review stage.

4.1.4 The UTH shall not downgrade the service life of the umbilical or the system performance below the functional requirements.

4.1.5 The underwater part of the umbilicals may be also attached directly to the SPS equipment at the preinstallation stage ashore or on FPU/FOP.

The surface part of the umbilical is structurally designed depending on the equipment used for systems for control, monitoring and emergency protection on the FPU/FOP.

4.1.6 The UTH shall be designed to allow an unimpeded immersion of the umbilicals.

4.1.7 To protect the UTH against corrosion they shall be provided with an independent cathodic protection or connected to the cathodic protection system of the SPS.

4.2 PULL-IN HEAD

4.2.1 A pull-in head shall be used to pull the umbilical along the seabed or through the I- or J-tube. The pull-in head shall be designed to withstand all installation loads without damage to the umbilical or its functional components.

4.2.2 The pull-in head shall be designed, if possible, to allow uninterrupted travel over rollers and through I- or J-tube risers without damage or snagging.

4.2.3 The pull-in head shall be designed to house the hose, electric and optical fibre umbilical termination heads. Electric and optical fibre cables shall be sealed to prevent seawater ingress.

4.3 SUBSEA UMBILICAL DISTRIBUTION UNIT

4.3.1 The SUDU shall mechanically and functionally connect the subsea umbilical to several subsea systems in a similar manner to the subsea umbilical termination head ([refer to 4.1](#)).

4.3.2 If a significant number of systems are to be connected, the size, mass, center of gravity and pull-in shall not affect the umbilical.

4.4 ANCILLARY EQUIPMENT

4.4.1 Joint box.

4.4.1.1 A joint box shall be used to join umbilical sub-lengths to achieve overall length requirements or to repair a damaged umbilical.

4.4.1.2 Each umbilical end to be joined shall have an armour termination, if applicable. These shall be joined using a connecting sleeve or barrel which shall allow for the transfer of the fluid from one sub-length to the other. The connecting sleeves and/or barrels shall allow operation of the umbilical during its design life.

4.4.1.3 The joint box shall be of a streamlined design, with a bend stiffener at each end if required, and shall be of compact size to facilitate reeling, storage and installation requirements.

4.4.1.4 The joining of the electric cables, optical fibres, hoses and tubes within the joint box shall be according to the manufacturer's written specification.

4.4.1.5 During operation, the joint boxes shall not be subjected to dynamic loads.

4.4.2 Weak links.

4.4.2.1 A weak link shall be designed to protect the umbilical, and equipment connected to the umbilical, from excessive loads. The required load at which the weak link shall be activated shall be defined in the manufacturer's written specification. The weak link shall be designed to have a design life equal to or greater than the umbilical.

4.4.2.2 The weak link shall have an override mechanism which shall be easily removable and replaceable when the weak link is installed on the sea bed. With the override mechanism in place, the weak link shall be capable of withstanding the maximum umbilical working load without suffering mechanical failure.

4.4.2.3 The weak link shall not prevent the safe shutdown of the wellhead equipment.

4.4.3 Buoyancy attachments.

4.4.3.1 To achieve necessary configuration, dynamics and buoyancy, a dynamic umbilical can necessitate buoyancy attachments in the form of collars, tanks, buoys, etc.

4.4.3.2 The method of attachment shall not induce stresses in excess of the allowable ones in the umbilical sheath, nor allow excessive strain of the umbilical and its components.

5 FACTORY ACCEPTANCE TESTS

5.1 GENERAL

5.1.1 The factory acceptance tests shall be carried out after fitment of the umbilical termination heads (end fittings).

5.1.2 Acceptance tests of the umbilicals shall be conducted according to a Register-approved program elaborated on the basis of Annex B to ISO 13628-5.

5.1.3 To confirm finally conformity of the umbilical and its components and proceeding from the structural requirements and assembling practice additional acceptance tests may be required. The amount of additional testing shall be established by the Register.

5.2 TESTING OF HOSES INCLUDED IN AN UMBILICAL

5.2.1 On completion of umbilical manufacture, the hoses included into an umbilical shall be subjected to the following tests:

- .1 proof pressure test;
- .2 flow test;
- .3 dynamic response;
- .4 fluid cleanliness;
- .5 geometric size control.

5.2.2 [Table 5.2.2](#) indicates the required ratio of proof and burst pressures to the design working pressure (DWP).

Table 5.2.2

Ratios of test pressure to DWP		
Proof pressure		Burst pressure
A ¹	B ²	
2,0	1,5	4,0
¹ Applicable on completion of hose manufacture and normally used once. ² Applicable following shipment of individual hose lengths and inclusion of hoses into an umbilical.		

5.2.3 The test pressure shall be measured at both ends of the hose and shall be maintained within $\pm 5\%$ over a minimum period of 30 min. At the end of this period, if the pressure has been maintained, the pressure source shall be isolated and the pressure-decay characteristic monitored over a minimum period of 60 min; and the hose assembly has no creeps.

Throughout the proof pressure test period, the ambient temperature shall be continuously monitored. There shall be no evidence of leakage or failure, neither shall umbilical construction have any deformation, during or at the end of the test period.

5.2.4 The manufacturer's written specification shall state the nominal flow rate that each hose shall be required to pass. The manufacturer shall calculate expected pressure drops for the specified fluid at nominal flow rate passed through the hose. A constant high pressure supply shall be connected to one end and the other end shall be vented to atmosphere.

The test fluid shall be passed through the hose until the pressure reading at the hose inlet is constant within 5 %, and the flow rate is constant within 5 %. The flow rate, pressure drop across the hose and fluid temperature at the inlet and outlet shall be recorded. The difference between the actual pressure drop and the calculated pressure drop shall not exceed the tolerance value stated in the manufacturer's written specification.

5.2.5 The dynamic response test shall be performed in accordance with the procedure described in Annex G to ISO 13628-5.

5.2.6 Upon satisfactory completion of all other acceptance tests, each hose length specified in the manufacturer's written specification shall be flushed with the specified test fluid. The highest possible flow rate shall be used which does not result in the hose being subject to a pressure higher than the DWP at the hose inlet. The fluid temperature shall be monitored at inlet and outlet continuously to ensure that the hose temperature rating is not exceeded. Each hose length shall be flushed for a complete volume change and thereafter until the cleanliness level is reached. At the end of this period, three consecutive fluid samples per hose length shall be taken at intervals of at least 10 min, using the procedure specified in ISO 4406. The cleanliness levels shall meet or exceed the value(s) specified in the manufacturer's written specification.

Short hose lengths may be connected together to facilitate the flushing requirements.

The flow test and the fluid cleanliness tests may be combined.

5.2.7 The hose shall be designed such that the change in length when the hose is pressurized from atmospheric pressure to its DWP shall be within the range $-1,5$ to $+2\%$.

PART X. ELECTRICAL EQUIPMENT

1 GENERAL

1.1 Electrical equipment of the SPS shall meet the international and field standards corresponding to the particular operating requirements. In case MS/DS/PS are used for the SPS maintenance, the electrical equipment of the SPS shall meet the requirements of Part VII "Electrical Equipment" of the MS/DS Rules.

1.2 Design documentation for electric power supply, lighting, communication and alarm, radio installations (including video surveillance), fire alarm system shall also meet the requirements of Parts X "Electrical Equipment" and XIV "Automation" of the MODU Rules, Parts X "Electrical Equipment" and XIV "Automation" of the FOP Rules to the extent as applicable.

1.3 The documentation to be elaborated (route plans, external wiring connection diagrams, connection diagrams, functional diagrams of automation, specifications for instruments, ancillary equipment, wiring hardware, etc.) shall enable wiring/connection of the SPS equipment and automation facilities, as well as start-up and normal operation of the SPS.

1.4 As a rule, a.c. systems shall be used on the SPS.

1.5 Use of earthed d.c. systems shall be subject to the Register special consideration.

1.6 All the SPS electric systems shall be equipped with an automatic system for continuous monitoring of insulation resistance which will activate visual and audible alarm at the SPS control station when the insulation resistance drops below 1000 Ohm.

1.7 All open metal parts of the equipment, which may be touched by personnel shall be earthed to the general protective structure of subsea module of the electrical equipment.

1.8 The voltage values in the electric systems shall be designed with due account of electric power consumption, allowable voltage drop and fluctuation and shall correspond to the design ones.

1.9 For permanent lighting equipment of the control stations the voltage shall not exceed 250 V. If necessary, step-down transformers and converters shall be used.

1.10 Internal spaces (compartments) of the tight protective structures with the process equipment, which forms a hazardous area, being part of the SPS shall be treated as zones in which the electrical equipment of an appropriate safe-type may be used with due regard for the composition of the atmosphere contained within these compartments under normal operating conditions. Tight compartments with gaseous atmosphere shall be equipped with a fixed atmosphere monitoring system.

1.11 The electrical equipment of the tight compartments shall meet the requirements of the MS/DS Rules, deviations from which shall be subject to the Register special consideration.

1.12 The electrical equipment intended for use in dry normobaric compartments shall be operable at relative humidity of 100 %.

1.13 The minimum degree of protection of the electrical equipment installed in the SPS spaces and areas shall be defined by the designer, but in no case it shall be lower than IP68.

1.14 Dangerous values of current strength on the external surfaces of equipment to be touched by divers during repair or maintenance of the SPS shall be prevented.

The current strength corresponding to the safe human "sensing level" is about 0,5 mA (d.c.) or 2 mA (a.c.), and the current strength corresponding to the "allowable level" is about 9 mA (d.c.) or 40 mA (a.c.).

1.15 All electric motors, motor starters and other electrical equipment shall meet the requirements of the relevant national standards, safety rules and these Rules.

2 ELECTRIC DRIVES

2.1 The requirements to electric drives shall conform to Part X "Electrical Equipment" of the MODU Rules and Part X "Electrical Equipment" of the FOP Rules to the extent, as applicable.

2.2 Drives of the pumps, compressors, etc. of power more than 1 kW shall meet the applicable requirements of Section 18 of Part X "Electrical Equipment" of the MODU Rules and Section 17 of Part X "Electrical Equipment" of the FOP Rules.

2.3 In using of the electrical equipment the internal spaces of which are filled with silicon-base dielectric liquid, tightness of the housing shall be maintained even in case when an internal short-circuit occurs.

2.4 Insulating properties of the dielectric liquid shall be automatically and continuously monitored and checked during periodic maintenance.

2.5 When inert gas-filled electrical equipment and cables are used, provision shall be made for a visual and audible gas leakage alarm released at the SPS control station.

3 CABLES AND CONDUCTORS

3.1 GENERAL

3.1.1 Electric cables with insulated conductors shall be capable of continuous operation in seawater environment.

3.1.2 Electric cables of the SPS power supply system and optical fibre cables of the SPS monitoring, control and safety system may be installed in umbilicals or separately.

3.1.3 Minimum bend radii of the electric cables, hoses, tubes and optical fibre cable shall be stated in the manufacturer's written specification.

3.1.4 A leak in the hydraulic part of the system shall not affect performance of the electric system.

3.1.5 Cable lead-ins to tight compartments shall be prevent leakage to the compartment in the event of seawater ingress into cables.

3.1.6 Electric cables of all electric circuits shall be in sheaths, which strength is calculated for external loads.

3.1.7 Electric elements of the subsea electrohydraulic components shall be installed in the SCM housing filled with dielectric liquid to compensate for the external pressure.

3.1.8 To minimize the electric power consumption, the solenoid-operated valves shall be activated by incoming electric impulses and hydraulically locked, with the exception of an electrically held common locking gate valves.

3.1.9 The surface and subsea equipment shall have a mandatory durable marking to indicate the environmental temperature, for example:

.1 Standard working temperature:

Lower temperature value: 0 °C and upper temperature value: 40 °C;

Marking: 0 °C –40 °C STD.

.2 Extended temperature range:

Lower temperature value: –5 °C and upper temperature value: 40 °C;

Marking: –5 °C –40 °C EXT.

3.1.10 Subsea sensors monitoring temperature of produced or injected fluid may operate outside the ranges indicated in [3.1.9](#) and their parameters shall be calculated at the design stage.

3.2 POWER CABLES

3.2.1 Power cable voltage ratings shall be selected from the range 0 V up to the standard rated voltages:

$U_0/(U \times U_m) = 3,6/(6 \times 7,2)$ kV rms, where: U_0 , U and U_m are as defined in Standards IEC 60502-1 and IEC 60502-2.

3.2.2 Power cables shall be insulated, twisted and/or sheathed in accordance with the manufacturer's written specification.

3.2.3 Power cables may be screened and oversheathed in accordance with the manufacturer's written specification.

3.2.4 The chosen insulation material shall be of virgin stock applied as a continuous seamless circular single/multiple extrusion, and shall meet the requirements of IEC 60502-1 and IEC 60502-2.

3.2.5 The minimum allowable insulation thickness shall meet the requirements of recognized and applicable national and international standards for submarine service which shall be cited in the manufacture written specification.

3.2.6 The surface part of power cables run on the offshore oil-and-gas facilities shall meet the applicable requirements of 18.7 of Part X "Electrical Equipment" of the MODU Rules and Section 17 of Part X "Electrical Equipment" of the FOP Rules.

3.2.7 The cables in hazardous areas, as well as the methods of their laying shall meet the requirements of 2.11 of Part X "Electrical Equipment" of the MODU Rules and 2.11 of Part X "Electrical Equipment" of the FOP Rules.

3.2.8 Subsea power cables shall be laid in compliance with the construction documentation approved by the Register. The construction documentation shall include the following:

- justification of selected operation diagram;
- workflow process;
- installation/laying procedure;
- burial procedure;
- composition of installation/laying facilities;
- justifying calculations of main installation/laying parameters;
- trenching plans/profiles.

3.2.9 In straight-line sections the cables, as a rule, shall be buried with the burying depth not less than 1,5 m. In water areas with seasonal ice cover where presence of ice gouging is revealed the subsea cable burying depth shall be assumed based on the design value of ice gouging which may be determined by the methods in 8.3.1 of Part I "Subsea Pipelines" of the SP Rules.

3.2.10 Installation of vertical protective risers and cables inside for surface structures up to terminal boxes shall be carried out at the closing cable assembly stage. Upon completion of work on cables tightening into protective pipe risers, the cables shall be fastened at the riser top flange, cable conductors shall be put in the terminal connection boxes.

3.2.11 Tension force and minimum bending cable radii shall be monitored when laying and they shall not exceed the values specified in the manufacturer's specifications. During cable operations tension forces (laying, drawing, areas joints, lowering to the bottom, burial operation) shall be demonstrated by calculations and specified in the construction documentation.

3.2.12 The maximum lateral effects in protective bendings of pipes (risers) to prevent cable deformation when drawing in the cables shall be determined by calculations. Tensioning machine for cable retracting into protective pipes shall be supplied with a recording device and automatic shutoff when the maximum permissible value of tension is reached.

3.3 SIGNAL CABLES

3.3.1 Signal cables shall be designed to transmit electrical control and communication signals in the voltage range 0 Vrms to $U_0/(U \times U_m) = 0,6/(1,0 \times 1,2)$ kV rms, where U_0 , U and U_m are defined in IEC 60502-1 and IEC 60502-2.

3.3.2 The signal cables shall be twisted, insulated and/ or sheathed, and may be screened and oversheathed in accordance with the manufacturer's written specification.

3.3.3 The signal cables shall be designed to meet the electrical signal transmission characteristics of the communications system adopted.

3.3.4 The chosen insulation material shall be o virgin stock applied as a continuous seamless circular single/multiple extrusion, and shall meet the requirements of IEC 60502-1 and IEC 60502-2.

3.3.5 The minimum allowable insulation thickness shall meet the requirements of recognized and applicable standards for submarine service which shall be cited in the manufacturer's written specification.

3.4 CABLE CONSTRUCTION

3.4.1 Splices (joints) necessary to achieve the final length requirements shall be carried out in accordance with the qualified procedures specified in the manufacturer's written specification.

3.4.2 Splices (joints) shall be subject to the same qualification and acceptance criteria as the insulated conductors and the cables.

3.4.3 Electric cores and cables shall be manufactured as continuous lengths.

3.4.4 If necessary, armouring or other forms of protection shall be provided.

3.4.5 On a design-specific basis, conductor strain relief due to compressive and tensile forces and the potential for damaging crushing forces that may arise in the laid-up components and/or deepwater service shall be considered.

3.4.6 The cable design shall take into account:

voltage ratings;

current ratings;

number of phases;

maximum ambient temperature;

maximum voltage drop along the cable length.

3.4.7 Structural analysis, taking account of data generated from the umbilical structural analysis ([refer to Part IX "Umbilicals"](#)), shall be undertaken to verify the acceptability of the electric cable design for tensile, compressive and fatigue loadings upon the conductors.

3.4.8 The cable construction shall also comply with [3.5.1.3](#) of Part IX "Umbilicals".

3.5 CONFIGURATION OF CONDUCTORS

3.5.1 The conductors shall be manufactured from annealed circular copper wire and shall comply with the relevant conductivity and material requirements of IEC 60228.

3.5.2 If stranded, each conductor shall comprise a minimum of seven strands.

3.6 CONDUCTOR CODING

3.6.1 The insulated conductors shall be identified by colour or by numbers. If numbers are employed, these shall be printed at regular intervals not exceeding 100 mm along the length of each core.

3.6.2 Coding shall be stable under heat ageing and shall not cause a failure.

3.6.3 The numbers and/or colours used shall be specified in the manufacturer's written specification.

3.7 CABLE TWISTING

3.7.1 Twisting of intermediate cores shall be under taken using helical cabling equipment.

3.7.2 For an intermediate lay-up operation, the cable cores shall be bound with a helically applied overlapping tape to ensure bundle stability and a circular cross-section.

3.7.3 The lay-up operation shall minimize compressive forces between the cores to minimize the extent of deformation of the insulation.

3.8 FILLERS

3.8.1 To achieve a circular consolidated arrangement, fillers shall be included in the interstices of the laid-up cores and the bundled components bound together using a binder tape, or the laid-up cores shall be consolidated by means of an extruded polymer applied directly over the cores so as to directly fill the interstices.

3.8.2 The filler and binder tape materials shall be compatible with other materials in the cable, in particular the electrical insulation.

3.8.3 The materials shall be as stated in the manufacturer's written specification.

3.9 SCREENING

3.9.1 If required, the cable shall be screened with plain or tinned annealed copper tape or a two-component tape comprising a thin film of copper bonded to a polymer-based substrate.

3.9.2 The thickness and number of layers and minimum cross-sectional area shall be as stated in the manufacturer's written specification.

3.9.3 The screening shall be electrically continuous throughout the cable length, and shall be applied in such a manner that its electrical continuity shall not be broken throughout its design life.

3.9.4 Metal tape screens, for electric cables or individual power cores, shall provide 100 % coverage of the enclosed electrical cores.

3.9.5 The screens shall not be applied directly over the twisted cores. They shall be applied helically with an overlap.

3.9.6 The drain wire shall remain in contact with the metallic part of the screen.

3.9.7 If present, a drain wire shall have a minimum of three strands and the total cross-sectional area shall not be less than 0,35 mm².

3.10 SHEATH

3.10.1 The electric cable sheath shall be of polymeric material incorporating protection against UV radiation and ozone, and shall be as stated in the manufacturer's written specification.

3.10.2 The chosen material shall be continuously and concentrically extruded over the laid-up cores to produce a uniform cross-section.

3.10.3 The material shall be compatible with seawater and the specified service fluids throughout manufacture, installation and service, and shall not degrade the quality of other materials with which it may be in contact in the lay-up.

3.10.4 The coefficient of friction between the sheath and the sheaths of other electric cables and/or other components shall be minimized.

3.10.5 As cable sheaths are in many cases sealed by boot-seal methods, the surface of the insulation shall be round, smooth and free from marks, indentations and surface defects.

3.10.6 The electric cable sheath shall be in compliance with the manufacturer's written specification.

3.11 IDENTIFICATION

3.11.1 The cables shall be uniquely identified in accordance with the manufacturer's written specification. As a minimum, the marking shall include:

- manufacturer;
- unique component reference (e.g. "Cable 3");
- batch number;
- voltage rating.

3.11.2 Embossed printing is not permitted.

3.12 CABLE END FITTINGS

3.12.1 The design of the electric/optical fibre cables shall recognize that the cables will be terminated in some form of waterblocking arrangements, which shall function throughout the design life (refer to [Section 4](#) of Part IX "Umbilicals").

3.12.2 The endurance of termination interface shall not be impeded by the design and materials of construction.

3.12.3 During design of the composite structures and/or structures different in pressure, it is necessary to ensure reliability of connections, with due regard for the possibility of cathodic disbonding, and/or provide a sealing device tailored for the design service life in seawater environment.

3.12.4 Provision shall be made for appropriate blind flanges to protect detachable joints exposed to sea-water environment. Such blind flanges shall ensure mechanical protection and prevent electrolytic interaction between adjacent contacts when subjected to electrical current induced in the device connected to the cable.

3.12.5 Additional information on the methods of cable terminations for subsea use may be found in technical specifications.

3.12.6 The cable end fittings shall be tested in accordance with the firm's (manufacturer's) documentation approved by the Register.

3.13 PERFORMANCE REQUIREMENTS

3.13.1 The d.c. resistance for each conductor shall not exceed the value defined in IEC 60228.

3.13.2 The d.c. insulation resistance for each electrical core shall not be less than the value defined in the manufacturer's written specification, which shall not be less than 500 Ohm km at 500 V d.c.

3.13.3 For power cables incorporating semiconducting screening layers (non-metallic layers), the resistivities shall not exceed the following values:

conductor screen: 1000 Ohm;

core screen: 500 Ohm.

3.14 PERFORMANCE CHARACTERISTICS

3.14.1 The following characteristics for each signal conductor pair shall be defined between upper and lower limits at frequencies within the operating bandwidth of the proposed system:

- attenuation;
- characteristic impedance;
- inductance;
- capacitance.

3.14.2 These transmission characteristics, and crosstalk limits between pairs of conductors, shall be as stated in the manufacturer's written specification.

3.15 OPTICAL FIBRE CABLES

3.15.1 Optical fibre cables shall be capable of continuous operation when immersed in a sea-water environment.

3.15.2 The fibre type shall be of either single-mode or multimode design depending on the information rate requirements. The design shall be as given in the manufacturer's written specification.

3.15.3 Individual fibre identification shall be by means of fibre colouring.

3.15.4 The fibres shall be contained in a package which shall prevent water ingress and minimize hydrogen contact with each fibre. Additional protection against hydrogen shall be incorporated in the form of a hydrogen adsorbent.

3.15.5 The cable shall be designed to provide mechanical protection for the fibres against tensile and crushing loads.

3.15.6 The design of the optical fibre cables shall recognize that the cables will be terminated in some form of waterblocking arrangements, which shall function throughout the design life (refer to [Part IX](#) "Umbilicals").

3.15.7 The long-term stability of termination interface shall not be impeded by the materials of construction or the design. Information on the methods of optical fibre cable termination for use subsea shall be contained in the manufacturer's written specifications.

3.15.8 The optical attenuation for each fibre on specified wave lengths shall meet the requirements given in the manufacturer's written specification.

3.15.9 The design of umbilicals and optical fibre cables shall provide protection of optical fibres against mechanical deformation.

3.15.10 Fibre splicing (connection) shall be carried out using a cable connector, including fibre connectors or connection box with the use of which any configuration of pipe lengths may be achieved with a possibility of installing the connectors and obtaining connected fibres not subjected to tensile and bending stresses.

Use of either of the two above methods shall preclude interaction of the fibres with water and hydrogen.

3.15.11 Jointing of the fibres shall be allowed/ with the use of high length qualified fusion splicing techniques. The acceptance level of splice loss attenuation shall be as define in manufacturer's written specification.

3.15.12 Splices shall be individually subject to tensile testing, to the load level defined in the manufacturer's written specification.

3.15.13 The splice region shall be suitably protected and the optical performance, after splicing, shall meet the requirements of the manufacturer's written specification.

3.16 FACTORY ACCEPTANCE TESTS

3.16.1 Electrical cables and conductors.

Upon completion of cable manufacture, the electrical cables and conductors shall be subjected to factory acceptance tests to check:

- d.c. conductor resistance;
- insulation resistance;
- voltage;
- transmission line characteristics;
- cross-talk;
- time-domain reflectometry.

Inductance, capacitance and impedance (characteristic wave impedance) shall be measured only in case when due to short length no measurement error is expected.

3.16.2 Optical fibre cables.

Upon completion of umbilical manufacture, the optical fibre cables shall be subject to optical time-domain reflectometry test.

4 SUBSEA ELECTRICAL DISTRIBUTED CONTROL SYSTEMS

4.1 The number of connections placed in series shall be kept to minimum. A back-up arrangement of cables shall be provided.

4.2 Voltage values at conductive connectors shall be maintained at minimum possible level to prevent occurrence of electrostatic discharges.

4.3 Electrical distributing cables of the manifold module and connecting cables from the umbilical termination-heads to the SCM shall be arranged in pairs and connected with the use of ROV (refer to [3.1](#) of Part XII "Marine Operations") or divers.

4.4 The SCM design shall as far as possible prevent the module from any penetration of water.

4.5 If one electrical line supplies more than two SEMs, provision shall be made for isolation of each SEM in case of line failure.

4.6 The electrical connecting cables shall be connected by ROV/divers using appropriate tools, with minimum time expenditures.

4.7 At least two protective barriers shall be provided between sea-water and conductive zone.

4.8 If an oil-filled system is selected, the cable assemblies shall be designed and installed such that any seawater entering the dielectric fluid moves away from the end terminations by gravity. The cables shall be installed into pressure-compensated fluid-filled lines. The fluid shall be of a dielectric type.

4.9 All insulation materials used in the subsea distributed control systems, when exposed both to sea/ formation water and to the dielectric liquid used shall remain intact. New materials shall be subject to classification tests to demonstrate their compatibility.

4.10 In the detail design process the following kinds of analysis shall be performed: reliability, serviceability and reparability analysis; FME[C]A (refer to [3.2.14](#) of Part XIII "Safety Assessment"); structural analysis (static characteristic of the system).

4.11 The reliability, serviceability and reparability analysis shall establish the following:

value of signal voltage (current) in the SEM and on the FPU at minimum and maximum umbilical length;

value of signal voltage (current) in the SEM and on the FPU at minimum and maximum number of the SEM involved in the subsea electrical power distribution system;

interference from subsea and surface power supply sources within the signal frequency band;

component frequency of output in the subsea and surface host facility in case of mutual interference of channels in the umbilical;

value of signal voltage (current) for dry and wet insulation of the umbilical;

Bit Error Rate (BER) and signal-to noise ratio in the SEM and on the FPU at minimum and maximum umbilical length;

dynamic boundary of the bite detection (indicator diagram) in the SEM and on the FPU at minimum and maximum number of the SCM in the subsea electrical power distribution system.

4.12 A monitoring and control system model shall be constructed. Operation time of the control and monitoring system shall be simulated without pressure in the borehole with the valve closed. Simulation shall deduce exactly respond time when hydraulic fluids are used to control the pressure in well.

4.13 If the analysis depends on the boost pressure corresponding to the basic control mode, the boost pressure with the control valve closed shall be included in the analysis.

5 ELECTRICAL POWER UNITS

5.1 Each EPU powered from UPS shall supply electrical power to subsea wells through the cables in the monitoring and control umbilical.

5.2 Each EPU shall be equipped with protective devices which ensure that in the event of malfunction in the power supply system the attending personnel is protected against current injury.

5.3 If the umbilical incorporates additional cables, the EPU output voltage shall be set for each power cable pair in the umbilical. Each pair shall be galvanically isolated from the rest of the system. The design shall be such as to allow for connection/disconnection of each pair and shall provide accessibility for maintenance and repair.

5.4 The following EPU parameters shall be monitored by the surface MCS or by the subsea DCS:

- input voltage;
- input current;
- voltage/current in the umbilical;
- insulation resistance.

5.5 Programmable logic controller and base computer of the EPU may be included into the monitoring and control system of the entire SPS or may be included into the monitoring and control system of the EPU as an independent unit.

6 UNINTERRUPTIBLE POWER SUPPLY

6.1 The UPS shall protection supply electrical power to the EPU, modem unit and the MCS. Only critical components that are necessary for operation of the system for monitoring, control and emergency protection shall be powered from the UPS. For example, HPU electrical pumps shall not be regarded as critical.

6.2 Each UPS shall have a capacity of 100 % of the total load and shall be designed to include future planned expansion of the system for monitoring, control and emergency protection.

6.3 The UPS battery back-up shall be capable of running the system for a time sufficient for safe shutdown of the equipment but for at least 30 min after loss of host-facility power. The safe shutdown time is specified by the design.

6.4 The following parameters shall be monitored by the MCS:

- input voltage;
- input current;
- UPS output frequency;
- UPS bypass mode;
- UPS on-line mode;
- UPS failure.

6.5 The UPS output parameters shall be within the range:

- a.c. voltage: $\pm 5\%$;
- frequency: (50 ± 1) Hz or (60 ± 1) Hz;
- maximum total non-linear distortion: 5 % or in accordance with the manufacturer's specification.

PART XI. SYSTEMS FOR MONITORING, CONTROL AND EMERGENCY PROTECTION

1 GENERAL

1.1 The operating reliability and safety of the systems for monitoring, control and emergency protection shall be confirmed at the design review stage by the results of the risk and failure effect analysis (refer to Part XIII "Safety Assessment" and Part X "Safety Assessment" of the OGE Rules).

1.2 Impact of the environment conditions (humidity, salinity, current, temperature, etc.) and the induced magnetic induction on the instrumentation sensitivity shall be minimized.

1.3 Components of the SPS systems for monitoring, control and emergency protection arranged at the FPU control station shall meet the requirements of Parts X "Electrical Equipment" and XIV "Automation" of the MODU Rules, Parts X "Electrical Equipment" and XIV "Automation" of the FOP Rules and Part IX "Special Requirements for Ensuring Explosion and Fire Safety" of the OGE Rules.

1.4 In designing of the SPS, it shall be taken into account that the structural composition of the systems for monitoring, control and emergency protection shall ensure continuous monitoring of the equipment and fault detection both with retrieval and without retrieval of the FPU equipment.

1.5 The systems for monitoring, control and emergency protection shall generally incorporate:

- hydraulic power units;
- hydropneumatic accumulators
- umbilical for control both the single (satellite) wells and the well clusters;
- SUDU;
- SUT to connect umbilicals and their branches to equipment of each well;
- subsea service modules for control of subsea X-mas tree and subsea manifolds;
- units for mating hydraulic and electrical lines for monitoring and control of actuators, arranged in functional nodes of the wellhead assembly and subsea manifolds;
- pressure and temperature sensors;
- test equipment.

1.6 Structural composition, components of the SPS systems for monitoring, control and emergency protection shall meet the requirements of ISO 13628-6 or relevant national standards.

1.7 The systems for monitoring, control and emergency protection shall be manufactured according to technical documentation approved by the Register. The items of the Register technical supervision are given in the SPS Nomenclature — refer to [Table 6.1](#) of Part I "General Regulations for Technical Supervision".

2 CONTROL STATIONS

2.1 Under normal operating conditions, control of the SPS shall be carried out from a common master control station where the operator is provided with all necessary information regarding safe functioning of the well fluid production, treatment and transportation processes.

2.2 Control stations arranged on the SPS are basic means for the operator's dealing with the equipment, and designed generally to control a cluster of at least 10 subsea wells. The control stations shall consist of:

- control panel of wells with subsea completion;
- HPU;
- EPU with consideration for the back-up independent power supply sources;
- MCS;
- subsea equipment electrical power supply stabilizer.

2.3 Control stations of the subsea well clusters shall provide:
order transmission to subsea equipment;
execution of orders with gate valve position indication;
wrong operator's order blocking, as well as fault/ failure signaling and recording with indication of fault/ failure location.

2.4 To monitor and control functioning of systems, preference shall be given to the use of mimic diagrams presenting location and position (open/closed) of all valves, flow directions and values of controlled parameters. The form of information presentation at the control station shall preclude misinterpretation thereof.

2.5 The control station shall display in real time actual responses in the nodal points of systems and devices, being part of the SPS, to all the actions undertaken by the operator.

2.6 In case the system for monitoring, control and emergency protection incorporates several control stations, provision shall be made for a hierarchical system of priority which provides no possibility of undertaking any actions for the SPS control from the control stations of inferior level without appropriate permission from the control station of superior level.

In well-grounded cases provision may be made for equivalent control stations, with a mandatory indication in each of the functions carried out by the other.

2.7 The system for monitoring, control and emergency protection shall be provided with back-up feature so that during the period of performing preventive and repair work the level of the SPS functioning safely is not lowered.

3 EMERGENCY FUNCTIONING ALGORITHM

3.1 In an emergency situation, the systems for monitoring, control and emergency protection shall provide shut-in of any well from the FPU control station with operation of a visual/audible alarm at the control station in cases of:

- well fluid pressure rise/drop at wellhead above/ below the specified limits;
- temperature elevation at wellhead above the limiting one;
- failure of electrical, hydraulic and pneumatic power supply.

3.2 The emergency operation time of shut-off devices of the subsea WHA and subsea manifold varies depending on the system type and remoteness of the controlled items and shall be minimized considering technical capabilities of the systems used.

3.3 Emergency situation/failure alarm shall adequately identify the time, location and failure nature.

3.4 Operation of alarm on the control station panel in the event when an emergency situation/failure occurs shall not hinder operation of alarm when other emergency situation/failure occurs.

3.5 The possibility of disabling the alarm shall be eliminated, and in the event of break of the alarm circuit, appropriate visual and audible alarm shall be actuated at the control station.

3.6 The SPS system for monitoring, control and emergency protection shall build up and present to the operator an adequate algorithm of actions to confine and eliminate the emergency situation/failure.

3.7 In the event of emergency situations occurred with potential quick development into an accident, the system for monitoring, control and emergency protection shall initiate operation of appropriate emergency shut-off valves with indication at the control station (ESD System).

3.8 The SPS systems for monitoring, control and emergency protection shall incorporate mechanically actuated back-up safety valves (spring, hydraulically, pneumatically actuated) operated from the control station.

3.9 In case where the SPS system for monitoring, control and emergency protection does not incorporate back-up non-electric systems, the electric systems shall have two independent power sources, each with a capacity corresponding fully to the design needs.

3.10 For tight compartments with dry atmosphere intended to accommodate equipment being operated, provision shall be made for automatic air composition monitoring systems and for autonomous fire extinguishing systems meeting the requirements of the MS/DS Rules.

3.11 The specified fire extinguishing systems and their automation extent shall ensure extinction of fires in tight compartments both manned and unmanned.

3.12 Special requirements for ensuring explosion and fire safety during operation of the oil and gas equipment on the FPU are set out in Part VI "Fire and Explosion Protection" of the FPU Rules and Part IX "Special Requirements for Ensuring Explosion and Fire Safety" of the OGE Rules.

4 TYPES OF SYSTEMS FOR MONITORING, CONTROL AND EMERGENCY PROTECTION

4.1 SYSTEM SELECTION

4.1.1 Factors that affect the system for monitoring, control and emergency protection are the following:

- offset distance from the control station and its type; data telemetry requirements;
- response-time requirements;
- cost (including whole life-cycle estimates that include cost of maintenance and lost production caused by monitoring and control system failures).

4.2 GENERAL DESIGN PRINCIPLES

4.2.1 All-hydraulic systems are generally the least complicated and the most reliable subsea production monitoring and control systems. They are relatively slow to respond (up to 10 min), compared to electrohydraulic systems, and have limited capability for providing data telemetry from the SPS. All-hydraulic systems are generally preferred for single satellite wells located relatively close to the control station (up to 7,5 km), and where project economics require minimum cost. The drawback of the systems lies in the absence of feedback with information on normal operation of the system. This may be proved indirectly through monitoring pressure in the control lines and measuring the amount of fluid supplied to the WHA valves and returned to the hydraulic fluid collector. In this case, the design of the umbilicals become more complicated and their dimensions are increased due to large number of hydraulic lines for all components to control functioning of the WHA and manifold of each well.

4.2.2 Electrohydraulic control systems replace hydraulic signals with electric telemetric signals, which essentially eliminate the signal-time portion of response time (up to 30 s) and have the capability to receive data and to monitor a wide range of devices owing to SEM. Electrohydraulic systems are typically preferred for multi-well developments (about 10 and more) for the distances from 7,5 km up to 28 km from the control station where operating flexibility, speed of operation and data telemetry is needed for well control and/or reservoir monitoring.

4.2.3 All joints in the hydraulic/electrohydraulic systems shall be made using fittings with seals which shall prevent leakages during installation of pipelines and operation of the systems (refer to ISO 13628-6).

4.3 ALL-HYDRAULIC SYSTEMS

4.3.1 Direct hydraulic systems.

For direct hydraulic systems, a separate hydraulic line is provided for "open/closed" function of valves fitted on the WHA or manifold of each well. This line shall be connected directly to the shut-off device (gate valve) actuator. No special equipment is required, other than an umbilical connector and routing of control lines to each function. Control is effected directly from the control station on the FPU/FOP Rules ([refer to Fig. 2](#) of Annex 3).

4.3.2 Piloted hydraulic systems.

Hydraulic fluid from the FPU/FOP is supplied through an umbilical to the subsea control module and hydropneumatic accumulator. The umbilical contains also separate hydraulic lines transmitting control signals to spring-loaded hydraulic valves of the hydropneumatic accumulators fitted on the manifold or WHA. The fluid is directed from the hydraulic valves of the hydropneumatic accumulators to actuators of the production valves and chokes. Use of above valves improves the system reliability since only one control signal is transmitted from the FPU/FOP to the subsea manifold (PLEM) or WHA. To reduce the time of response to the control signal, the control fluid is supplied from the subsea hydropneumatic accumulators. The response time depends also on the amount of fluid in the control lines. Therefore, the piloted hydraulic systems are recommended for the distances from 7,5 km up to 22 km between the control station on the FPU/FOP and the subsea wellhead equipment. The controls and instruments shall be fitted on the front panel of the FPU/FOP control station ([refer to Fig. 3](#) of Appendix 3).

4.3.3 Sequential hydraulic systems.

Sequential hydraulic systems shall use control modules with power fluid from subsea accumulators and special pilot valves which do not require a separate line for each function. An increasing sequence of hydraulic pressure steps on a single pilot line common to all pilot lines in a module causes activation of different pilot valves at each pressure level. The sequence and time of closing is ensured by adjusting flow areas of the chokes. The number of hydraulic lines is minimized, since only one pilot line per wellhead equipment is needed.

The disadvantage of this approach is that the opening sequence of subsea valves is predetermined, with no flexibility for operating valves in different sequence. This type of system has most commonly been used as a back-up to an electrohydraulic system, but has also been used as an independent system ([refer to Fig. 4](#) of Appendix 3).

4.3.4 Controls and instrumentation shall be installed on the front panel of the control desk in FPU/FOP.

4.4 ELECTROHYDRAULIC SYSTEMS

4.4.1 Direct electrohydraulic systems shall transmit signals through multiple individual conductors in the control umbilical directly to solenoids on directional control valves located in the SCM. An electrohydraulic system is sensitive to signal power losses in the multiple conductors as the offset distance from the control station increases over 5,5 km.

4.4.2 An electrohydraulic monitoring and control system requires an additional electrical control cable, or the inclusion of electrical cables within the hydraulic control/chemical- injection umbilical ([refer to Fig. 5](#) of Appendix 3).

4.5 MULTIPLEXED SYSTEMS

4.5.1 Multiplexed systems are materialized with the use of multiplexed electrohydraulic means which control the WHA valves, subsurface safety valves and regulating chokes of the PLEM module sections.

4.5.2 The multiplexed systems shall serve a well cluster with simultaneous performance of all well monitoring/control functions both when fulfilled by operators and automatically.

4.5.3 Multiplexed electrohydraulic systems shall transmit control signals to one or more subsea SEMs by means of coded, digital messages via a single pair of conductors. The SEM decodes the message and takes the appropriate action, such solenoid actuation or query of a subsea sensors ([refer to Fig. 6](#) of Appendix 3).

4.5.4 For the multiplexed systems, the EPU may be as a separate system, and also it may be part of the modem unit or the MCS.

4.6 AUTONOMOUS SYSTEMS

4.6.1 SPARCS shall provide locally generated power and control to the subsea production facility. Communication with the surface facility may be via subsea acoustic link or via a combination of acoustic/satellite/ radio links. The basic system functions are the same as for a multiplexed electrohydraulic system ([refer to Fig. 7](#) of Appendix 3).

4.6.2 The autonomous systems consist of two groups of components: surface control unit and subsea control unit.

4.6.3 The surface control unit shall be installed on the FPU and consist of an operator's control panel, an acoustic telemetry system, power lines. The acoustic telemetry system incorporates an acoustical transponder, receiver/transmitter, directional hydrophone communication panel, which is located in the telemetry system or in cable system.

4.6.4 The subsea control unit shall be placed at a distance less than 5,5 km from the well and provide monitoring and control of the following components:

- electronic control unit installed adjacent to the wellhead;
- housing valves and sensors;
- hydraulic control module with solenoids;
- generators of electric power for the control unit;
- accumulator battery. If necessary, tight interiors of the battery installation compartments shall be filled with dielectric liquid;
- transponder acoustic system controlled from the FPU (in cases of emergency, control from the SCM may be permitted);
- hydraulic power plant including pumps, hydraulic motors, hydropneumatic accumulators, filters installed in two lines, which is made as a closed loop system to return all possible leakages to a special tank.

4.6.5 The autonomous systems shall be used at distances of up to 22 km.

4.6.6 It is necessary to establish planned maintenance intervals for all autonomous systems:

- replacement of hydraulic fluid and accumulator batteries — every 2 years;
- replacement of hydraulic filters and hydraulic motors, hydropneumatic accumulators, transponders and electric generators — every 5 years.

4.7 INTEGRATED MONITORING AND CONTROL BUOYS

4.7.1 The system concept lies in use of an integrated control buoy (ICB), dynamic riser and radio communications in a configuration that uses an anchored buoy connected to the SPS equipment via a flexible riser.

4.7.2 The integrated buoy control system shall be completely autonomous, that is, it shall control well parameters, as well as interact with the SPS equipment without any need for permanent communications with the control station on the FPU.

4.7.3 The integrated buoy control system shall exercise control of all functions of the X-mas tree and manifold, as well as the critical parameters ([refer to Section 3](#)) ESD.

4.7.4 The dynamic riser shall incorporate signal cables, hydraulics, chemical reagents and tool lines and provide a link between the buoy and subsea monitoring and control system, distribute hydraulic and electric power and control various valves proceeding from indications of control sensors.

4.7.5 Radio communication from the FPU shall be carried out at the direct visibility distance within microwave range at regular time intervals controlled by the buoy.

4.7.6 The typical information shall contain current operating parameters of the well and integrated buoy:

- temperature, pressure, valve position, hydrocarbon leakage;
- current hydraulic fluids stores available and battery capacity.

4.7.7 The systems with the integrated control and monitoring buoys shall be used for single satellite wells at distances of about 28 km between the buoy and FPU and with the system operation time of several seconds ([refer to Fig. 8](#) of Appendix 3).

5 TYPICAL CONTROL AND MONITORING FUNCTIONS

5.1 MONITORING FUNCTIONS

5.1.1 A typical list of parameters typically monitored by subsea-located sensors of the systems for monitoring, control and emergency protection shall be as follows:

- wellhead pressure;
- injection well pressure and temperature;
- annulus pressure;
- manifold pressure;
- production temperature;
- manifold temperature;
- hydrocarbon leak detection;
- WHA valve position;
- production choke position;
- production choke differential pressure;
- sand detection;
- downhole monitoring;
- multiphase flow;
- corrosion monitoring;
- pig detection.

5.2 CONTROL FUNCTIONS

5.2.1 A typical list of valves controlled by the subsea control system shall include the following equipment and shut-off-regulating valves ([refer to Fig. 1](#) of Appendix 3):

- annulus swab valves (ASV);
- annulus master valve (AMV) (between production tubing (PT) and production casing string);
- production swab valves (PSV);
- upper production master valves (UPMV);
- lower production master valves (LPMV);
- production wing valves (PWV);
- X-cross-over valves (XOV);
- control valves (CV);
- chemical injection unit (CIU);
- chemical injection valves (CIV);
- chemical injection distributing valves;
- annulus wing valves (AWV);
- surface-controlled subsurface safety valves (SCSSV);
- distributed control systems (DCS);
- directional control valves (DCV);
- subsea chokes;
- production valves fitted on X-mas tree;
- annulus bleed valves on tree flow line;
- X-cross-over injection valves;
- methanol/chemical injection valves;
- tree piping chokes (can require two control functions per choke);
- injection chokes (can require two control function per choke);
- manifold valves;
- equipment used to monitor characteristics of hydraulic fluid, leaks, valve "open/closed" position;
- hydropneumatic accumulators;
- hydraulic, spring-loaded or pneumatic actuators for closing X-mas valves and regulating choke valves;
- manifold internal pigging loop.

5.2.2 Typical amounts of the hydraulic fluid to actuate tree valves shall be from 1 to 4 l per valve, to actuate SCSSV — several cubic millimeters.

5.2.3 Typical low pressure to actuate the X-mas tree valves shall be from 20 to 34,5 MPa, typical high pressure to actuate SCSSV — from 51,7 to 69 MPa. The pressure varies depending on purpose of the valves and installation depth of WHA.

5.2.4 All subsea hydraulically actuated valves shall be housed in the SCM which is normally installed on the tree foundation. Depending on the installation depth and accessibility for divers use shall be made of two SCM types: remotely retrievable and retrievable with the use of divers.

5.2.5 The hydropneumatic accumulators complete with system piping shall be installed as part of the X-mas tree. In some cases, the hydropneumatic accumulators are members of the subsea control module which enables these to be retrieved. A remotely retrievable separate package of hydropneumatic accumulators may also be used. The package size depends on planned operating time, type/size of umbilicals and distance between control station on the SPS and wellhead equipment location.

5.2.6 The SCM shall be securely locked to the SCM mounting base considering applicable separation forces, transport and installation loads. The locking mechanism shall incorporate a mechanical override feature to release the SCM in case of failure of the mechanism.

5.3 SUBSEA CONTROL MODULE PARAMETER MONITORING

5.3.1 The following subsea parameters shall be monitored inside the SCM:

- hydraulic supply pressure;
- communication status;
- internal voltages in SEM;
- internal temperature in SEM;
- internal pressure in SEM;
- self-diagnostic parameters;
- hydraulic fluid flow;
- hydraulic return pressure.

5.3.2 Consideration shall be given to self-diagnostic to detect malfunctions to external sensor systems connected to the control module (e.g. downhole monitoring, multiphase flow meters, sand detectors).

5.4 CONTROL AND MONITORING OF HYDRAULIC POWER UNIT

5.4.1 A surface monitoring and control system on the FPU consists of a HPU, EPU and MCS.

5.4.2 HPU shall include: tanks, pumps, hydraulic fluid purification monitoring system, hydraulic control valves.

5.4.3 The HPU supplies high/low pressure hydraulic fluid to the users with the use of pumps driven by electric motors. Pneumatic drive is used as a redundancy.

5.4.4 Emergency shutdown devices shall ensure emptying of the system after the subsea emergency shutoff valves are closed

5.4.5 The HPU installed on the FPU is typically controlled locally, but may be controlled from the operator's control station or monitored from the MCS.

A local control panel shall be fitted with all necessary gauges, switches and indicators to enable control and monitoring. Provision for setting pumps in manual mode shall be provided.

5.4.6 If the facilities provide for ESD capability, then the HPU and local control panel shall incorporate devices to bleed-off system-control pressure upon execution of ESD. Unauthorized starting of any HPU/ESD circuit shall be prevented.

5.4.7 The HPU parameters monitored shall include the following:

non-regulated supply pressure(s);

regulated supply pressure(s);

fluid levels;

pump-accumulator unit, booster, pressure controller status;

fluid flowrate;

return flow;

hydropneumatic accumulator filter status;

ESD indicators.

5.4.8 Parameters of the hydraulic control system equipment and working fluid properties shall meet the conditions of application on a particular SPS ([refer to 5.10](#)).

5.5 MASTER CONTROL STATIONS

5.5.1 The MCS is a surface unit that controls and monitors the subsea production system. It can range in complexity from a manually hydraulic panel to an automated computer digital system.

5.5.2 The MCS shall be designed to include the following capability to:

- operate safely in the sited environment;
- respond to the host safety systems;
- provide effective operational interface;
- display and warn of out-of-limit (fault) conditions;
- display current operating status;
- provide a shutdown capability.

5.5.3 The MCS may optionally provide the following additional capabilities, depending on the SPS design:

- sequenced operation of valves;
- software interlocks;
- process-control interconnections with control station;
- data collection and storage;
- remote communication to offsite control centre;
- interface with workover vessel;
- rate of change of pressure in the event of leaks;
- hydrate detection by pressure/temperature curve comparison;
- flowrate control by detection of choke position and pressure sensors of production up- and downstream of choke.

5.5.4 The application software of the MCS shall be simple. Start-up operations after shutdown situations shall be under the complete control of the operator with a minimum number of inherent interlocks. The MCS and DCS shall provide the operator interface and automated functions for the production control and monitoring system, as appropriate to the selected configuration.

5.6 SUBSEAS CONTROL MODULES

5.6.1 The subsea control modules being part of the hydraulic and electrohydraulic production control and monitoring systems shall be packaged in autonomous units/housings. Depending on the system type, the SCMs shall include some or all of the following:

- electrohydraulic or hydraulically directed DCVs and other valves (check valves and shuttle valves);

- feed-through electrical connectors and hydraulic couplers;

- hydraulic manifolds and tubing;

- internal sensors and transmitters;

- filters/strainers;

- hydropneumatic accumulators;

- pressure compensators;

- pressure intensifiers;

- chemical-injection regulation valves;

- SEMs.

5.6.2 Installation and replacement of a single SCM shall not affect adversely operation of any other SCM.

5.7 SUBSEA ELECTRONIC MODULES

5.7.1 The SEM hardware shall be based on the use of microprocessors and power supply units to obtain an acceptable level of reliability and flexibility in the design.

5.7.2 The SEM shall be protected against water intrusion.

5.7.3 The SEM shall be capable of performing sequenced monitoring operations and/or sequenced controlling based on one command from the MCS.

5.7.4 The SEM shall have capacity to temporarily store all relevant data gathered from the subsea production system, and additionally shall have at least 25 % spare memory capacity.

5.7.5 Current limitation shall be provided for all SEM outputs.

5.7.6 The SEM interface to sensors and DCVs shall be limited to the minimum practical number of signal types and formats. Description of signals shall be specified for each application by reference to International Standards, or by detailed description of signal type.

5.7.7 To enable interchangeability, all the SEMs used shall be standardized.

5.7.8 The SEM software shall be structured in functional tasks, which shall be designed, coded and tested as independent units.

5.7.9 These units typically conform to the defined tasks in the real-time operating system, or the main program calls in a real-time monitor if a simple sequential scan is used.

5.7.10 The software shall be designed to make later software updating and maintenance easy to perform.

5.7.11 The SEM software shall have built-in diagnostic functions to simplify testing and debugging of the modems, microprocessors and subsea sensors.

5.7.12 The SEM shall be programmable to allow for reprogramming from the FPU.

5.7.13 The SEM software shall be so designed as to be capable of including information from the DHPT system if available in the design.

5.8 MODEM UNITS

5.8.1 Modems, filters and isolation transformers are typically included in the unit. The modem unit may either be connected to the MCS, dedicated to the production control and monitoring system, or, alternatively, may interface directly with the DCS via a communication interface unit (part of the DCS).

5.8.2 Each communication link shall employ a qualified communication protocol. In either configuration, the communications protocol shall provide means of ensuring the security of the data being transmitted.

5.8.3 The following modem unit parameters shall be monitored by the MCS or DCS:
input voltage;
input current;
umbilical voltage/current;
line insulation.

5.9 ELECTRONIC TEST UNITS

5.9.1 The electronic checker is a modular unit including a portable PC and necessary power/signal interfaces. The electronic test unit shall be capable of monitoring and control related directly to the operation of the SCM. All commands described in the communication protocol shall be supported. In addition, the electronic test unit shall be able to simulate one or more SCM.

5.9.2 For the subsea electronic systems, reliability of components shall be defined by calculation with indication of the specified design life without any failures and malfunctions.

5.9.3 The workmanship and reliability of the components shall meet, as a minimum, the requirements of MIL-STD-2000 or an analogue thereof.

5.10 HYDRAULIC FLUIDS. GENERAL

5.10.1 The following types of hydraulic fluids are used for the subsea production systems: fresh water with some chemical additives, mixture of fresh water with ethylene glycol and, in some cases, mineral based hydraulic fluid.

5.10.2 The water-ethylene glycol mixture shall be basically used in the electrohydraulic monitoring and control systems, while fresh water is used in the hydraulic systems for monitoring, control and emergency protection.

5.10.3 The physical and chemical properties of the water-ethylene glycol mixture depend on the ethylene glycol content (commonly from 10 to 40 %).

5.10.4 The viscosity of the mixture varies with the seawater temperature (from 2 to 10 °C).

5.10.5 The hydraulic fluid purity of -/15/12 code as specified in ISO 4406 is recommended cleanliness level.

5.10.6 If the supervisory bodies prohibit release of an ethylene glycol-containing mixture to the environment, the system shall be designed in closed version which makes the umbilical design more complicated.

6 FACTORY ACCEPTANCE TESTS

6.1 GENERAL

6.1.1 FATs of the components of the system for monitoring, control and emergency protection and the system itself as a whole shall be performed prior to delivery.

6.1.2 The manufacturer shall develop and agree with the Register a comprehensive test program. The program shall demonstrate that all systems and components of the equipment delivered meet the design requirements and will function over the specified period without failure during operation. Step-by-step procedures with objectives and acceptance criteria shall be available prior to start of the FAT.

6.1.3 Complete tests of the system for monitoring, control and emergency protection by subsea production may be performed on the design installation models unless the real installations are available.

6.1.4 As a minimum, during the complete FAT, attention shall be paid to the following:

- electrohydraulic DCV performance and leak rates;
- accuracy of the system for monitoring, control and emergency protection;
- communication system sensitivity and noise immunity;
- electrical power quality requirements;
- strength test by 1,5 times the working pressure of SCM, all tubing, hydropneumatic accumulators, pipework and hydraulic components;
- relief valve pressure setting;
- fluid and system cleanliness;
- verification of equipment mating;
- electrical cable insulation resistance and conductance;
- test-leaking of appropriate reservoirs/canisters;
- conductance of sacrificial anodes.

6.1.5 All SEMs shall be tested for:

- tightness;
- temperature cycling;
- vibration;
- forced failure.

6.1.6 The purpose of the temperature tests shall be to verify that all components will function over the design temperature range. The purpose of the vibration tests shall be to control quality of welds and joints.

6.1.7 Environmental impact exerted by subsea devices and electronic systems shall be in accordance with the manufacturer's written specification and shall be within the limits of the requirements of the national supervisory bodies.

PART XII. MARINE OPERATIONS

1 GENERAL

1.1 Marine operations for the SPS movement to the installation site shall meet the requirements of the Rules for Planning and Execution of Marine Operations.

1.2 All the SPS components shall be so designed and manufactured that their preparation for transportation and installation on the site shall be performed at minimum.

1.3 All ships and facilities involved in marine operations, associated with transportation, installation, planned maintenance, emergency operations, conservation and utilization of the SPS, as well as appropriate techniques and procedures of performing these works shall be stated in the marine operation design and approved by the Register.

2 INSTALLATION OF THE SUBSEA PRODUCTION SYSTEM COMPONENT

2.1 All the SPS components and individual mounting units shall be fitted with marking to ensure correct orientation of the SPS during installation, and containing identification number, mass, CoG and cargo sling securing point positions.

2.2 Operations for transportation of the SPS elements/components, launching of the SPS elements and individual mounting units from a ship, barge, submersion thereof and setting may be permitted only if the actual weather conditions correspond to the design ones.

2.3 The design time of installation of the SPS on field shall be as minimum as possible.

Number of ships and craft involved simultaneously in operations for installation of the SPS on field shall be as minimum as possible.

2.4 When the SPS components and individual mounting units are launched from ship/barge and are submersed, control over positioning of the SPS components and individual mounting units on the installation site shall be exercised, and stability of the ship/barge shall be maintained in conformity with the marine operation design documentation.

2.5 The SPS elements/components launching operations and installation shall be monitored and documented with the use of subsea TV systems, sonar systems and other means stipulated by the design.

2.6 Provision shall be made for interruption of the SPS installation operations in the event when off-limit situations occur (fire, accidents, deteriorating weather conditions, etc.) with safety of the SPS and ship/craft involved in marine operations being ensured.

2.7 Upon completion of installation, compliance of the installation and connections of the SPS components with the design solutions shall be confirmed by the results of special diver's survey or with the use of ROV and documented.

3 IN-SERVICE MAINTENANCE AND REPAIR

3.1 PLANNED MAINTENANCE

3.1.1 Where the SPS is maintained by the FPU/MODU/FOP personnel permanently present on the field, all the planned SPS maintenance operations shall be carried out with the use of especially provided equipment for performing underwater works (diving equipment, submersibles), tools, attachments, hoisting appliances, special equipment for well workover.

3.1.2 Planned maintenance of the SPS, associated with performance of underwater works, shall be carried out within periods corresponding to favourable combination of weather conditions influencing performance of these operations (wind, waves, currents, ice, etc.).

3.1.3 All the SPS maintenance operations shall be carried out and documented in accordance with the requirements of technical regulations.

3.1.4 When planning the SPS maintenance operations, it is recommended to give preference to the use of ROV.

3.2 EMERGENCY REPAIR

3.2.1 The possibility of occurrence of various emergency situations and accidents which bring the threat to the SPS performance, safety of the attending personnel and environment shall be considered at the design stage with the use of risk assessment methods (refer to [Part XIII](#) "Safety Assessment").

In this case, it is essential to confirm the opportunity of accident or emergency situation elimination with the use of supply vessels and facilities which are available in the operator's disposal or means that may be promptly involved.

3.2.2 Plans of measures to eliminate accidents or emergency situations on the SPS shall provide for the safety of personnel involved in emergency operations and elimination of accident consequences.

4 KILLING OF THE WELL

4.1 Schedule of work to kill the wells with subsea injection shall be worked out at the SPS design stage.

The SPS, its process systems, as well as the systems for monitoring, control and emergency protection shall be so designed as to provide normal functioning of the SPS with some wells selected to be suspended, as well as long-term safe SPS condition with the entire cluster of serviced wells to be suspended.

4.2 The scope of marine operations for killing of the wells shall be as minimum as possible.

4.3 Schedule of work to kill the wells shall comply with the requirements of the national supervisory bodies.

5 DECOMMISSIONING

5.1 Schedule of work to decommission wells with subsea injection as well as utilization of individual components or the SPS as a whole shall be worked out at the SPS design stage and approved by the Register.

5.2 In case of complete decommissioning of the SPS, structures and equipment left on the seabed, as well as their size and height above the seabed shall be minimum.

5.3 The results of the SPS decommissioning work shall be documented. The location of the remained structures and equipment shall be put on nautical charts.

5.4 Schedule of work to decommission wells shall comply with the requirements of the national supervisory bodies and international conventions.

PART XIII. SAFETY ASSESSMENT

1 GENERAL

1.1 SCOPE OF APPLICATION

1.1.1 The objects of risk analysis are subsea objects and their components being part of the SPS, classified in compliance with these Rules, including:

foundations, pile bases and other systems and components used to maintain the SPS in design position;

protective structures of the SPS intended to prevent external effects;

barrier structures of the SPS;

wellhead equipment of producing and injection wells;

subsea pumping systems;

field subsea pipelines and flow lines;

well fluid gathering and treatment systems including subsea manifolds, separators, compressors, valves and other processing equipment;

well fluid offloading systems;

power supply systems of the SPS;

flexible and dynamic risers;

umbilicals;

marine operations.

1.1.2 This Part shall not apply to:

subsea pipelines which are classified in agreement with the SP Rules;

subsea equipment used in well workover and construction activities, if such equipment is a part of a relevant drilling system or a unit and to be removed from the seabed upon completion of well construction.

1.1.3 Safely assessment shall cover accidents caused by the following impacts and loads:

extreme hydrometeorological conditions;

seismic events;

hazardous geological phenomena;

hazardous hydrological phenomena;

external impacts on the SPS components, including those during marine operations, fishing, work performed on field facilities;

failures of the SPS equipment and associated field facilities;

internal and external corrosion;

fatigue failures of the SPS materials and structures;

human errors during the SPS operation; combination of above impacts and loads.

1.1.4 The following hazards and their consequences shall be considered for the safely assessment:

seal failures and leakages in the SPS components;

damages and failures of the SPS protection and safety means;

changes in the SPS orientation and position relative to those specified in the design;

loss of operability of the SPS components and the systems as a whole;

other possible off-limit situations.

1.1.5 Risk analysis for the SPS with regard to safety of the FPU personnel, population, environment, and facilities and structures of the offshore oil-and-gas fields is mandatory for submitting as a part of the design to the Register.

1.2 TERMS AND DEFINITIONS

1.2.1 For the purpose of this Part the following terms and definitions (refer also to [1.1](#) and [1.2](#) of Part I "General Regulations for Technical Supervision") have been adopted:

Accident means a failure of structures and (or) technical devices installed on a hazardous production object, uncontrolled explosion and (or) a blowout of hazardous substances (oil, petroleum products, condensate, natural and associated petroleum gas, chemical agents, process fluids and gases) harmful for personnel, population and environment.

Risk means a combination of an event probability and its consequences, which may be defined as a frequency of hazardous events which may initiate possible harm to personnel and environment and cause material damage in excess of acceptable level:

property (material) risk means a design frequency and extent of material losses and damage over a certain period of time, associated with malfunctioning of the field facilities caused by various accidents;

acceptable risk means a risk which level is allowable and substantiated on economic and social considerations;

environmental risk means a design frequency of events and processes harmful for the environment as a result of hazardous impacts due to hazard factors and accident situations;

social risk, or F/N curve means a relation between the frequency of events F where not less than N people of this number have been injured. It defines severity of the potential accident consequences.

Accident scenario means a complete and formalized description of accident events and processes, including their space-time parameters, cause-and-effect relations and the quantitative characteristics of the accident and its consequences.

Risk analysis means a process of hazard identification and risk assessment for the environment and field construction facilities. The risk analysis means use of all available information for hazard identification and assessment of risk of a certain event, accident and associated situations.

Risk assessment means a process used for determination of frequency/probability of the risk occurrence, including analysis of consequences and combination of both.

Hazard identification means a process of identifying and recognizing of existing hazard, as well as determination of hazard characteristics with regard to effect on the SPS.

Accident initiating event means an event, occurrence or external condition creating on its own or in combination with other events, occurrences and external conditions, a possibility of origination and evolvement of an accident.

Incident means failure or damage to technical means used on hazardous production facilities, any deviations from the process conditions, as well as the requirements of the normative documents which lay down the requirements for safe performance of works on the hazardous production facilities.

Working order means a condition of an object, at which it complies with all the requirements of design documentation.

Failure criterion of the SPS means an indication or a combination of indications of the SPS operable condition disturbance as specified in the design documentation.

Safety in emergency situations means condition of protection of population, objects of national economy and environment against hazards in emergency situations.

Maintenance means a package of operations or an operation to maintain operability of a product or equipment.

Operation means a package of works for commissioning of equipment and maintaining thereof in working order and operable condition through carrying out maintenance, repair, technical diagnostics and other kinds of operations.

Technogenic emergency situation means a condition where, as a result of an accident occurred on the object, normal conditions of human activities are disturbed, lives and health of people are threatened, damage is done to the environment and national economy.

Hazardous substances mean flammable, oxidizable, combustible, explosive, toxic, highly toxic substances causing hazard to the environment, the release of which into the environment is prohibited or limited.

Damage means disturbance of the working order of the object, with the serviceable condition being maintained.

Reliability means a property of the object to retain with the time within specified limits the values of all parameters characterizing capability to fulfill the required functions within the specified operating conditions and modes.

Serviceable condition means a condition of the SPS, at which it is capable to perform the required functions with parameters established by the requirements of technical documentation throughout its design life.

Failure means malfunction in serviceability of the object.

Risk management means elaboration of requirements and recommendations to lower the risk level.

1.3 BASIC PRINCIPLES OF SAFETY ASSESSMENT

1.3.1 Safety assessment is aimed at verifying the compliance of the design, manufacture, construction and maintenance of the SPS with the requirements of:

- national standards;
- normative documents of the Register;
- recognized international standards.

1.3.2 Safety assessment is carried out in compliance with safety concepts based on the following principles or combination thereof:

principle of unconditional priority of safety as compared with any technical and economic benefits and advantages;

principle of risk acceptability, in compliance with which the lower permissible and upper risk levels, and within this range — an acceptable risk level are established having regard to the economic factors;

"to foresee and to prevent" principle;

principle of necessary sufficiency of measures to prevent, localize and minimize accident consequences;

principle of successive approximation to guaranteed safety.

1.3.3 Safety shall be regularly assessed at all stages of the SPS lifetime beginning from giving birth to the idea and concept of its creation, at the stages of investment substantiation, feasibility study, engineering and detailed design.

1.3.4 For safety assessment the following information shall be submitted:

- environmental conditions;
- SPS layout diagrams and plans;
- functions, modes and specifics of the SPS operation;
- design impacts and loads;
- descriptions of processes, functioning diagrams, process charts and drawings;
- calculations and substantiations to ensure operability of the SPS at specified loads and impacts;
- information on associated craft and supporting structures;
- list and description of basic arrangements aimed at reducing probability of accidents;
- description of measures aimed to mitigate accident consequences;
- justification of the acceptable risk criteria adopted.

1.3.5 The results of safety assessment (Hazard and Operability Study — HAZOP) are as follows:

confirmation of the fact that the design and application project of the SPS meet the requirements for ensuring safety;

identification of the cases of non-observance and/or signs of insufficient measures to ensure safety.

1.4 BASIC REQUIREMENTS FOR RISK ANALYSIS

1.4.1 Risk analysis results are presented as part of the design documentation which consists of declaration of industrial safety conforming to the established requirements.

1.4.2 The ALARP ("as low as reasonably practicable") concept widely used in international and national practice is adopted in this Part.

1.4.3 Risk analysis shall be aimed at:
justification of objective decisions on acceptable and achievable risk levels on the SPS;
elaboration of requirements and recommendations on safety management throughout design, construction and operation of the SPS.

1.4.4 Risk analysis is based on the maximum full accessible information including data on accident rate of the SPS systems and components operated abroad.

1.4.5 The process of risk analysis shall contain:
planning and organization of work;
identification of hazards;
risk assessment;
elaboration of requirements and recommendations on reduction of risk levels (risk management).

1.4.6 At the stage of work planning it is necessary:
to appoint the risk analysis performers;
to justify the necessity, target, tasks and terms of the risk analysis;
to define limits of the analysis, technological and other links of the object (objects), degree of detail of the risk analysis;
to identify sources of information and provide availability of information on the object of analysis or similar objects;
to assess and take into consideration the information, personnel, calendar, financial and other resources affecting the scope and completeness of risk analysis;
to select and justify the risk analysis techniques consistent with the tasks set and limitations identified;
to develop and substantiate the acceptable risk criteria.

1.4.7 At defining objects, targets and tasks of the risk analysis the following shall be reviewed:

all stages of the SPS life cycle (design, construction, marine operations, installation, commissioning, operation and possible modifications, decommissioning, conservation, utilization);

all essential conditions of the SPS application, its technological and other links (well fluid transportation, power supply, monitoring and control).

1.4.8 The risk analysis terms shall be determined within the frames of preparation of the pre-design and design documentation with due regard for the following limitations:

not earlier than the stage at which data defining the SPS concept application are obtained;
not later than the stage at which the analysis results can be accounted for in the course of design development without any need for complete revision of the design solutions taken.

Situations where the risk analysis is carried out at the final design stage without any possibility to account for its results shall be avoided.

If necessary, the risk analysis may be performed at several stages as appropriate information is generated.

For the purpose of selection and appointment of the risk analysis performers it is necessary to assess their qualifications and experience and consider the possibility to involve independent experts and specialists from the design organizations and the representatives of the Register and supervisory bodies who have not participated in designing.

2 RISK ANALYSIS

2.1 HAZARD IDENTIFICATION

2.1.1 The hazard identification task is detection, definition and maximum complete description of all possible hazards for application of the SPS as part of the offshore field facilities.

Detection of the existing hazards is made on the basis of the information on the given object operational conditions, operation experience of similar or like systems, expert appraisals and statistical data.

2.1.2 The importance of hazards for the SPS is evaluated by:

SPS layout and application conditions;

presence and characteristics of used hazardous substances with a potential of their uncontrolled leaks (outburst);

complexity and diversity of constituent parts, components and members of the SPS;

long periods of use of the SPS with restricted possibilities of maintenance;

technological links of the SPS by lines/ umbilicals of well fluid transportation, power supply and process control;

possibility and characteristics of external technogenic and natural impacts.

2.1.3 Advantage in use at the hazard identification stage was gained by qualitative methods ([refer to 3.2](#)) based on sequential systematic consideration of components, characteristics and operational conditions of the safety assessment objects.

2.1.4 In identification of hazards the measures shall be taken to reduce the influence of limitations inherent in the identification methods used.

Hazards recognized during identification as insignificant are not subsequently considered and are neglected.

2.1.5 The results of hazard identification are as follows:

a list and characteristics of hazards and undesirable events capable of causing accidents on the SPS;

justification of measures to reduce effects and impacts of hazards identified in further analysis;

identification of the SPS components which require detailed consideration in further risk assessment.

2.2 RISK ASSESSMENT

2.2.1 At the stage of risk assessment the hazards detected in the course of identification shall be analyzed in terms of compliance with the acceptable risk criteria.

2.2.2 Risk assessment involves frequency analysis of initial and intermediate events, analysis of intensity of hazardous effects and their consequences and analysis of the result uncertainties.

2.2.3 For the purpose of the event frequency analysis and assessment, the following approaches are normally used:

statistical data on accidents and reliability of the SPS and other subsea facilities and structures similar in design and operating conditions to the type considered are used;

logical-and-graphical methods of "event tree" or "Fault tree" methods of analysis are applied;

expert appraisal with consideration of the opinions of independent specialists experienced in design and/or use of the SPS is performed (refer also to Part X "Safety Assessment" of the OGE Rules).

2.2.4 It is recommended to use expert appraisals and risk ranking methods in case of statistical data lack. Where such approach is used, the events under consideration are subdivided by a probability, severity of consequences into several groups with risk assessment by combination of probability and severity, e.g. with high, intermediate, low and insignificant risk degree. Normally, the high risk degree is unacceptable, the intermediate degree requires a complex of measures to be taken for reduction of risk, the low degree is recognized to be acceptable and the insignificant degree may be neglected ([refer to Figs. 2, 3](#), Appendix 4).

2.2.5 The analysis of the accident consequences includes assessment of impacts on people, environment and third party property. Analysis of consequences shall consider assessment of physical and chemical characteristics of hazardous effects (fires, explosions, emissions of toxic substances, etc.). For this purpose, the tested accident models and criteria of damage to affected objects, including the SPS itself shall be applied.

2.2.6 Environmental risk assessment includes calculation of the following indicators: values of maximum design leaks of hazardous substances into the environment, their intensity and duration at accidents on the SPS with consideration for peculiarities of their locations, technical characteristics and operating modes under normal conditions of operation and in the event of the SPS equipment failure;

annual average of leak and emission frequency due to failures and accidents on the SPS;

averaged leaks in time;

total annual averaged leaks.

The calculation of the maximum leaks for all modes shall be combined with hydraulic calculations of the well fluid production, treatment and transportation systems ([refer to Figs. 1 — 3](#) of Appendix 4 and Part X "Safety Assessment" of the OGE Rules).

3 METHODS OF SAFETY AND RISK ASSESSMENT

3.1 GENERAL

3.1.1 In selection of the methods of safety and risk assessment, consideration shall be given to:

- aims and tasks set forth;
- consistence with the design stage concerned;
- sufficiency of methodics and information support;
- sufficiency of statistical data;
- labour intensity and duration of assessment.

3.1.2 In selection of the methods of safely and risk assessment, consideration shall be also given to their inherent combinations of formalized and expert techniques of assessment and the independence of each method using expert appraisals from the expert qualification.

3.1.3 In assessing safely and risk it is necessary to assess contributions of the SPS constituent parts failure risks to the overall risk of accidents and to use these data for elaboration of recommendations.

3.1.4 The results of safely and risk assessment shall include an analysis of uncertainly and result accuracy.

The main causes of uncertainties are insufficient information on the SPS operating conditions, statistical data on reliability of the equipment and component parts used, human factor, as well as assumptions in the accident models adopted. The causes of uncertainty shall be identified and presented in the results.

3.1.5 The analysis of uncertainty shall be completed by transmission of the initial parameter uncertainties and assumptions used in risk assessment into the assessments of the risk analysis result uncertainties.

3.2 QUALITATIVE METHODS

3.2.1 The qualitative methods of risk analysis include:

Check-List and "What-If" methods;

Hazard and Operability Study (HAZOP);

Failure Mode and Effects (Criticality) Analysis (FME[C]A).

3.2.2 Check-List and "What-If methods or their combination refer to a group of qualitative hazard assessment procedures based on studying of the operating conditions of the object. The methods are based on systematic reviews of the design solutions adopted and their versions in agreement with preliminarily prepared list of issues reflecting the safety requirements and conditions of application of the assessment object. The Check-List and "What-If methods are fairly simple if preliminarily provided with unified forms and blanks for analysis and presentation of results.

The above methods are most effective in studying safety of well-known objects with a minor risk of major accidents.

3.2.3 The Check-List method is used to confirm compliance of an object being designed or operated with the current standards, regulations, rules and good marine practice.

The check-list is drawn up on the basis of an analysis of normative requirements. The check-list may include the requirements of international standards and rules to be examined with the aim of possible application and harmonization with the national normative documents.

The result of the check-list method is a list of deviations from the safety requirements which shall be eliminated or justified and agreed in subsequent design. An example of drawing up of a check-list for the analysis of accident situation is given in Part XV "Safety Assessment" of the MODU Rules and Part XV "Safety Assessment" of the FOP Rules.

3.2.4 The "What-If method uses questions beginning with "What-if and considers the development of situations described therein in the form of relevant scenarios.

The list of the scenarios considered is compiled on the basis of design and operation experience gained in similar objects including foreign experience and may include situations not regulated by current national normative documents.

The results of the "What-If method is a list of hazardous conditions of application of the SPS, their components on which accidents are likely to occur.

3.2.5 The results of using the Check-List and "What-If methods may be used in settling of a question regarding the need for preparation and agreement of special specifications, enterprise standards and other documents.

3.2.6 Examples of using individual elements of the Check-List and "What-If methods are given in Appendix 1 to Part XV "Safety Assessment" of the MODU Rules and Appendix 1 to Part XV "Safety Assessment" of the FOP Rules.

3.2.7 Hazard and Operability Study (HAZOP) method investigates the effect of deviations of technical parameters (physical and chemical composition, pressure, temperature, etc.) from the requirements of the Technical Regulations from the viewpoint of hazard occurrence.

3.2.8 In the course of HAZOP analysis possible deviations in operation, their causes and possible consequences are identified for each operating mode of the SPS and its components.

3.2.9 A standard set of key words that reflect qualitative, quantitative, temporal, logic, cause-and-effect and other deviations (such as "no", "more", "less", "as well as", "another", "other than", "opposite to", etc.) used in combination with design and technical parameters of the SPS, is employed.

Examples of combination of key words and characteristics are as follows:

"NO" — no supply of fluids when it shall take place according to the process;

"MORE" ("LESS") — increase (reduction) in values of operational variables in comparison with the specified values (pressure, flow rate, temperature, etc.);

"AS WELL AS" — new components are included (air, water, impurities);

"ANOTHER" — condition different from normal operation (start-up, stop, closing or opening of regulating and shut-off valves, etc.);

"OTHER THAN" — total change of the process, contingency, destruction, depressurization, monitoring and control system failure, etc.

3.2.10 In order to implement the HAZOP method the following documentation is required:

flow charts specifying use of the SPS in different functioning modes (commissioning, normal mode, emergency mode, emergency shutdown, scheduled shutdown, etc.);

diagrams of technological links and lines with their physical and chemical characteristics;

data on systems and means of parameter monitoring and process control (alarms, sensors, regulators, actuators and their conditions in various modes).

3.2.11 In the course of the HAZOP analysis qualitative characteristics (probability and severity) of hazards posed by accident situations which may develop as a result of deviations being investigated are determined.

3.2.12 The HAZOP analysis results are presented on special flow sheets (tables) that contain:

descriptions of deviations being analyzed

characteristics of potential accident situations (their hazard and criticality);

description of measures aimed at detection and prevention of hazardous deviations;

proposals for alterations and/or actions to improve safety and/or operability of the SPS.

The hazard of the deviations may be determined using criticality criteria similar to FME[C]A method ([refer to 3.2.14](#)).

3.2.13 In addition to identification of hazards and their ranking, the HAZOP method permits to clear up incompletenesses and inaccuracies of data on processes and the measures to ensure safety.

3.2.14 Failure Mode and Effects [Criticality] Analysis (FME[C]A) is used for qualitative safety assessment of engineering systems and is applied for detection of failures causing accidents or contributing to occurrence thereof.

The following shall be carried out in implementation of the method:

systematic consideration of potential failures (types and causes of failures) of each engineering system part or the SPS components;

determination of effects caused by this failure with identification of their criticality using the FME[C]A method;

Modules, units and components the failures of which are critical shall be further detailed or be considered with the use of more complicated methods of safety assessment and risk analysis.

3.2.15 The FME[C]A analysis may be used:

at the SPS design stage, to determine the necessity of additional safety measures or their reduction;

in settling the issues associated with extension and modification of the field construction facilities — to determine influence on other facilities;

during operation of the SPS — to identify single failures likely to result in severe consequences.

3.2.16 The FME[C]A method is similar to FMEA method, but it allows to add results of analysis due to the fact that failures are ranked with regard to criticality characteristics — combination of probability (or frequency) and severity of failure consequences. Consideration of criticality parameters allows to substantiate the priority of safety measures.

3.2.17 In practice, the following objects and impact characteristics may be selected for the analysis of the SPS accident criticality:

environment (SPS installation depth and seabed areas) in way of the offshore field development;

material objects being part of the field construction facilities or other objects in way of field construction and the results (well production rate, expenses for restoration after failure or accident, etc.).

When using the SPS attended by personnel, the impact objects shall include human factor and submarines used.

3.2.18 Recommended indicators (indices) of the and criticality levels and criteria in terms of probability and severity of consequences of failure (event) are shown below in the "probability — severity of consequences" matrix.

Criticality of failure may be defined by the following hazard ranks:

A — thorough detailed risk analysis is mandatory, special safely measures are required for reduction of risk;

B — detailed risk analysis is desirable, safety measures are required;

C — risk analysis and safety measures are recommended;

D — no risk analysis and additional safely measures are required.

In the case under consideration, rank A corresponds to the highest (unacceptable) risk degree that requires immediate safety measures to be taken. Ranks B and C correspond to the intermediate risk degrees and the rank D to the safest conditions. The concept of criticality is close to the risk concept and therefore may be used in quantitative analysis of accident risk.

Expected frequency of occurrence (1/year)		Severity of consequences			
		Catastrophic	Critical	Non-critical	Failure with negligible consequences
Frequent failure	>1	A	A	A	C
Probable failure	$1 - 10^{-2}$	A	A	B	C
Possible failure	$10^{-2} - 10^{-4}$	A	B	B	C
Infrequent failure	$10^{-4} - 10^{-6}$	A	B	C	D
Practically unlikely failure	$<10^{-6}$	B	C	C	D

3.2.19 The FME[C]A results are presented in the form of standardized tables with a full list of equipment and components, types and causes of possible failures, failure detection means (alarms, monitoring and telemetric devices), assessments of frequencies and consequences and recommendations on hazard mitigation.

3.2.20 The FME[C]A methods correspond to the HAZOP level in terms of the set of initial data, complexity and detailing of the results obtained. These methods may be used in combination.

3.2.21 Examples of use of individual FME[C]A elements are given in [Figs. 1 — 3](#) of Appendix 4 of these Rules, as well as Appendix 5 to Part XV "Safety Assessment" of the MODU Rules and Appendix 5 to Part XV "Safety Assessment" of the FOP Rules.

3.3 QUANTITATIVE METHODS

3.3.1 Quantitative methods of safety and risk assessment use:

Logical-and-graphic methods of presentation and analysis of accident situations (failure and event trees, state-transition diagrams, etc.);

inclusion and use in calculations of quantitative data on characteristics of accident events and processes.

The logical-and-graphic methods are used to account for the interaction between the assessment object elements, identification and consideration of the cause-and-effect relations between the events that make up the stages of accident scenario development.

3.3.2 Fault tree analysis (FTA) permits to detect combinations and sequences of equipment and component failures, personnel errors and external (technogenic and natural) effects causing the main event, i.e. the accident.

The failure tree is constructed according to typical models or expert appraisals by two basic methods:

"from the top downwards" — from an "undesirable" event (emission of harmful substances into the environment, material damage, etc.) by means of identification of events and conditions that make this event possible and subsequent detailing thereof down to so called "initial" events with known or independently assessed occurrence frequencies;

"from the bottom upwards" — from "initial" events by means of sequential construction of their combinations defined as "intermediate" events until the events assessed as "undesirable" ones are reached.

The FTA method is used:

to analyze likely causes of accident occurrence;

to calculate accident occurrence frequencies based on the knowledge of "initial" event frequencies.

3.3.3 Fault and event tree analysis permits to construct a set of sequences of events which develop in the course of an accident from some main event to be analyzed from the viewpoint of accident development.

Initial events are selected with consideration for data on accidents which took place and risk assessment results obtained by the qualitative methods of analysis.

The frequency of each stage of development of an accident is found by multiplying the previous stage by probability of occurrence of the event. For instance, accidents with loss of integrity of the primary safety barrier of the SPS can develop with retaining of hazardous substances, as well as with releasing thereof into the environment depending on the conditions created (integrity of the secondary safety barriers).

3.3.4 Fault and event tree techniques allow to review the events and conditions of various nature in combination initial failures of processing and monitoring equipment, functioning of safety systems, actions of operator, external effects, etc.

3.3.5 Fault and event tree techniques may be used in combination:

fault tree technique — to assess probability of occurrence of potentially hazardous events;

event tree technique — to assess probability and sequences of development of such events with assessment of the possibility of their growing into accidents.

3.3.6 Quantitative methods of risk assessment are characterized by calculation of risk indices and can include one or several of the above methods or use their results.

3.3.7 Performance of the quantitative analysis involves:

availability of information on reliability and failure rate of the SPS equipment, conditions of functioning thereof in various modes, environmental conditions, etc.;

use of mathematic models and calculation procedures for the assessment of physical and chemical and other phenomena accompanying the accidents;

experience gained in use of these methods and high qualification of personnel.

3.3.8 Fault and event tree techniques are fairly labour consuming and shall be used for analysis of application designs or revamping of sophisticated and essential engineering systems.

3.3.9 Particular objects of the quantitative risk analysis (totality of field construction facilities, separate SPS, its process package, some types and scenarios of accidents, etc.) shall be identified at the initial stages of risk analysis. Limitations of the quantitative risk analysis methods are as follows:

- high labour intensity, cost and duration of preparatory and analytical works;
- necessity of performing repeated investigations in case of actual changes in the configuration of the object being analyzed;
- subjective nature of experts' actions to be included in the review and to assess additional safety measures;

3.3.10 The possibility of obtaining results with significant statistical uncertainty which make the justification of practical safety measures difficult, shall be considered.

3.3.11 Examples of using individual elements of the fault and event tree techniques are given in Appendices 2 and 3 to Part XV "Safety Assessment" of the MODU Rules and Appendices 2 and 3 to Part XV "Safety Assessment" of the FOP Rules.

4 RISK MANAGEMENT

4.1 RECOMMENDATIONS ON RISK REDUCTION

4.1.1 Recommendations on risk reduction shall be one of the main results of risk analysis. Elaboration of recommendations on risk reduction, that is risk management, is the final stage of the risk analysis.

4.1.2 Risk may be reduced by the measures:
that reduce probability of accident occurrence;
that reduce severity of the accident consequences.

Measures that reduce probability of an accident (preventive measures) shall prevail over the measures that reduce accident consequences.

4.1.3 Measures that reduce probability of accident occurrence include, with the following priority:

measures that reduce probability of fault occurrence;
measures that reduce probability of fault development into accident;
measures related to the systems for emergency protection.

4.1.4 Measures that reduce severity of the accident consequences include:
measures that provide change in the SPS application and design concept, e.g. functions performed by subsea field construction facilities, selection and layout of the SPS components, the SPS siting, etc.;

measures dealing with organization, equipment and readiness of emergency services.

4.1.5 Risk reduction (reduction of probability and/or limitation of consequences) can be achieved due to measures either of technical or organizational nature.

Organizational arrangements made during the SPS operation may supplement or compensate a limitation of possible technical measures on reduction of hazard.

4.1.6 When measures on risk reduction are developed, account shall be taken of their effectiveness (influence on the level of safety) and possible limitations of the technical, material and financial resources available for this purpose. Primarily, simple recommendations and measures that require the least expenses shall be considered.

4.2 KEEPING RECORDS OF ACCIDENT SITUATIONS

4.2.1 To identify, analyze and monitor hazards associated with the SPS operation, regular and full records of accident situations shall be kept (refer also to 3.6 of Part X "Safety Assessment" of the OGE Rules).

The most hazardous situations are damages and failures caused by:
unsealing of the SPS components and joints as a result of external effects;
tearing and cracking of welds and base metal of structures due to manufacturing errors,
breach of construction procedures;
through corrosion flaws;
faulty sealing of joints in service, etc.

4.2.2 Information on the SPS accidents shall contain description of conditions at the beginning of an accident, data on accident development, physical and statistical models and accident control arrangements.

5 SAFETY CRITERIA

5.1 ELABORATION OF SAFETY CRITERIA

5.1.1 Safety criteria are established and used in the following forms:
compulsory observance of safety rules in accordance with the requirements of legal and standard technical documents;

observance of established acceptable risk criteria.

5.1.2 The acceptable risk criteria may be:
determined by the customer within the technical assignment for design;
specified by standard technical documentation;
elaborated at the stage of risk analysis planning with possible clarifications in the course of stage completion or obtaining analysis results.

5.1.3 Acceptable risk criteria shall be agreed with the Register at the design review stage.

5.1.4 The main factors in establishing the acceptable risk criteria are:
soundness — consistency with good marine practice and approved safe procedures;
comparability of criteria for alternative versions of offshore oil-and-gas field construction;
adequacy of comprehension and ability to be verified.

5.1.5 The acceptable risk criteria for the SPS, as applied to possible SPS impacts on the environment are elaborated and established using the following indices:
maximum one-time design amounts of harmful leakages into the environment per year;
totality of frequencies of exceeding the specified amounts of harmful leakages into the environment per year.

The above criteria shall account for ecological sensitivity of the development area and vulnerability of individual elements of the ecological systems (refer to information on leakages in Part X "Safely Assessment" of the OGE Rules).

5.1.6 In accordance with the ALARP (As Low AS Reasonably Practicable) "acceptable risk" concept adopted in this Part, categories of the acceptable risk criteria for the environment are:

unacceptable risk — risk of leakages (combinations of leakage amounts and frequencies of their exceeding) at which design solutions are recognized as unacceptable and requiring revision or change-over to safer practices;

acceptable risk — risk of leakages for which the measures taken may be considered as sufficient.

The transitional area between the unacceptable and acceptable levels of risk for the environment is defined as an area of acceptable risk wherein additional safely measures are considered with due account of technical and economic indices of the offshore oil-and-gas field development.

5.1.7 The risk acceptability criteria as applied to material damage shall be approved by the customer.

5.1.8 Examples of establishing risk acceptability criteria as applied to impacts on the environment from subsea wellhead equipment are given in [Appendix 4](#).

TYPICAL SUBSEA WELLHEAD SYSTEM

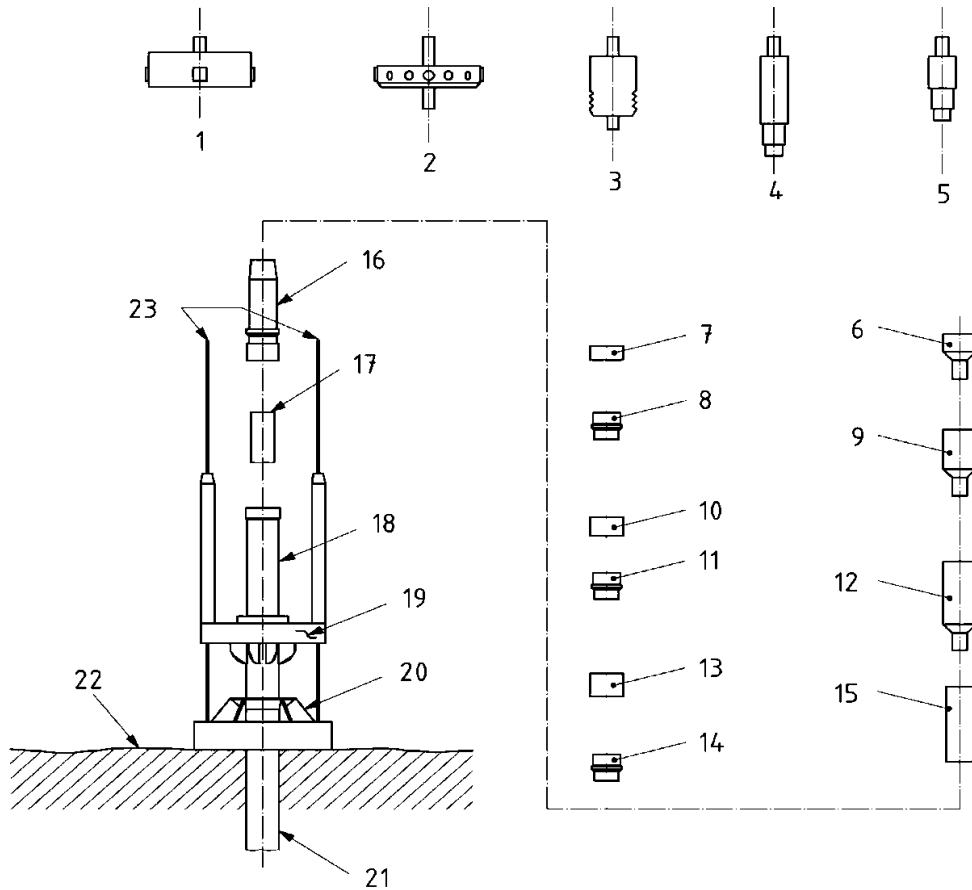

Fig. 1

- 1 — temporary guide base (TGB) running tool;
- 2 — housing running tool;
- 3 — high-pressure housing running tool;
- 4 — casing hanger running tool;
- 5 — test tool;
- 6 — wear bushing;
- 7 — annulus seal assembly;
- 8 — casing hanger;
- 9 — wear bushing;
- 10 — annulus seal assembly;
- 11 — casing hanger;
- 12 — wear casing;
- 13 — annulus seal assembly;
- 14 — casing hanger;
- 15 — housing bore protector,
- 16 — high-pressure wellhead housing;
- 17 — casing;
- 18 — low-pressure conductor housing;
- 19 — permanent guide base (PGB);
- 20 — temporary guide base (TGB);
- 21 — conductor casing;
- 22 — sea floor;
- 23 — guidelines

TYPES OF X-MAS TREES

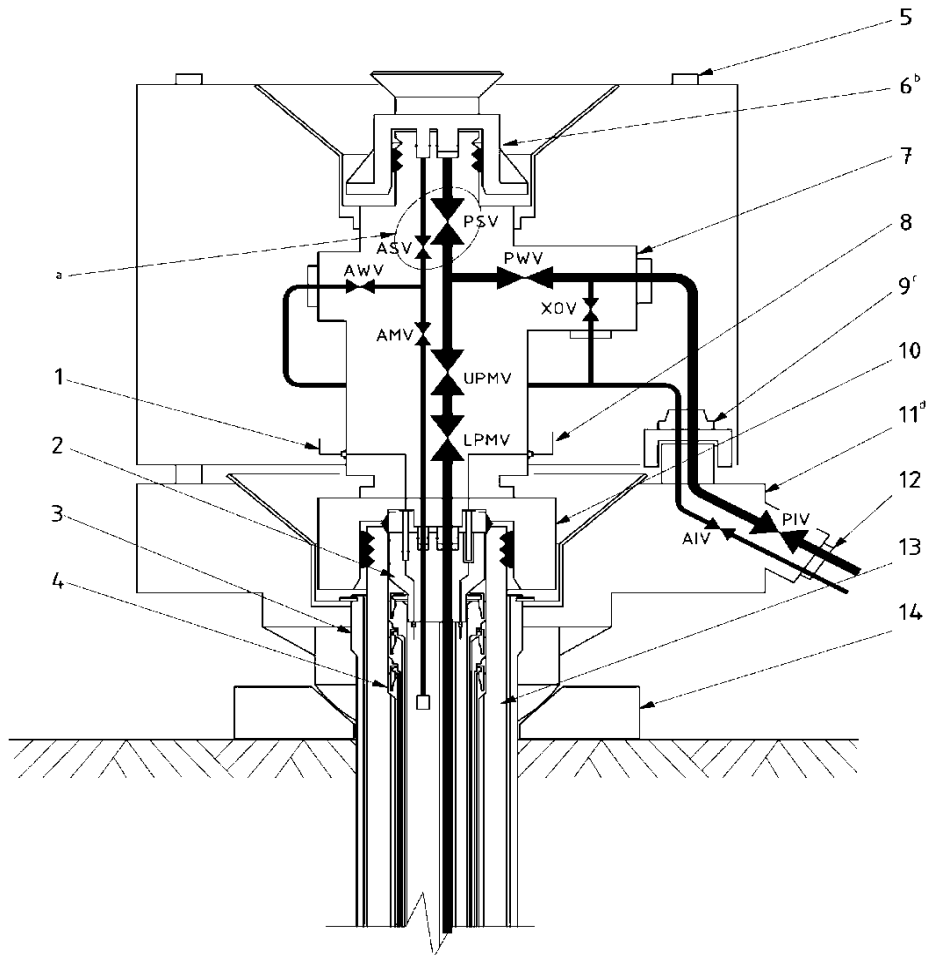

Fig. 1

Vertical X-mas tree (VXT):

- 1 — surface-controlled subsurface safety valve (SCSSV) control line;
- 2 — tubing hanger (TH);
- 3 — conductor housing;
- 4 — casing hangers and seal assemblies;
- 5 — guideposts (optional);
- 6 — XT cap;
- 7 — X-mas tree (XT);
- 8 — downhole pressure temperature transmitter monitoring line;
- 9 — flowline connector;
- 10 — XT connective fitting;
- 11 — guidebase;
- 12 — flowline/tie-in spool fitting;
- 13 — wellhead;
- 14 — drilling guidebase or template slot;
- a — production swab valve (PSV) and annulus swab valve (ASV) may be substituted with plugs;
- b — XT cap may be pressure-containing or non-pressure-containing;
- c — flowline connection shown connected to guidebase, but may also be connected directly to WHA;
- d — production guidebase shown

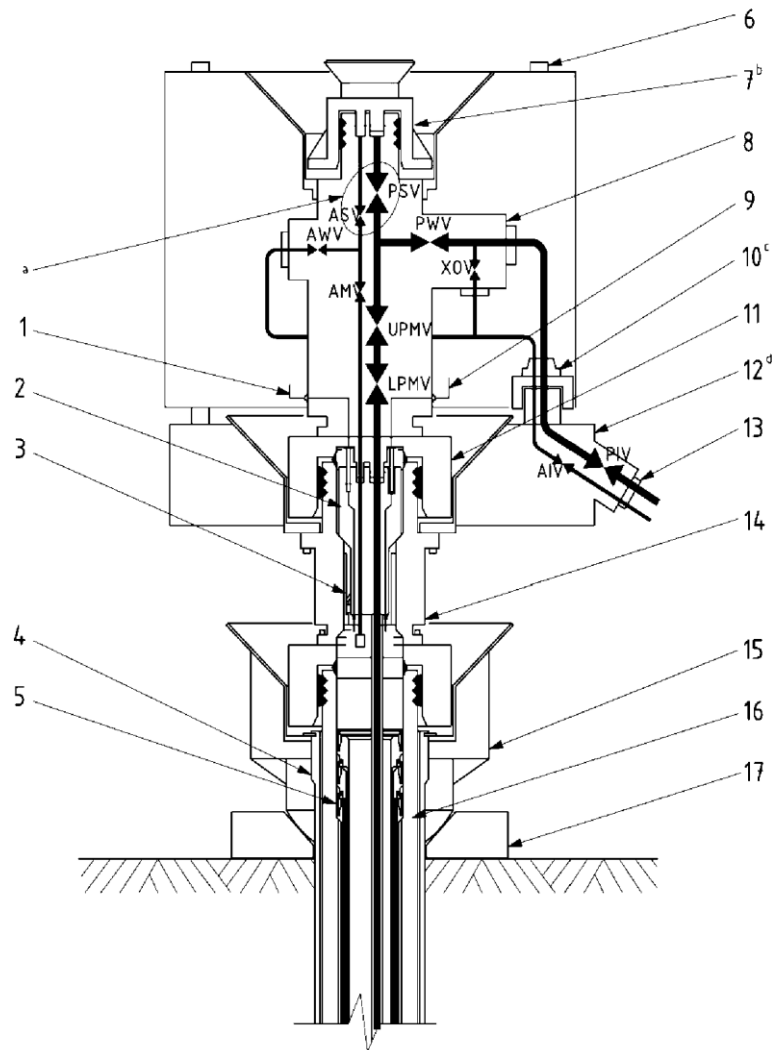

Fig. 2

Vertical X-mas tree (VXT) shown with tubing spool:

- 1 — surface-controlled subsurface safety valve (SCSSV) monitoring line;
 - 2 — tubing hanger (TH);
 - 3 — orientation sleeve;
 - 4 — conductor housing;
 - 5 — casing hangers and seal assemblies;
 - 6 — guideposts (optional);
 - 7 — XT cap;
 - 8 — wellhead (X-mas) tree;
 - 9 — downhole pressure temperature transmitter monitoring line;
 - 10 — flowline connector;
 - 11 — XT connective fitting;
 - 12 — guidebase;
 - 13 — flowline/tie-in spool fitting;
 - 14 — tubing spool;
 - 15 — XT guidebase;
 - 16 — wellhead;
 - 17 — drilling guidebase or template slot;
- a — production swab valve (PSV) and annulus swab valve (ASV) may be substituted with plugs;
- b — XT cap may be pressure-containing or non-pressure-containing;
- c — flowline connection shown connected to production guidebase, but may also be connected directly to WHA;
- d — production guidebase shown (allows connection of lowliness)

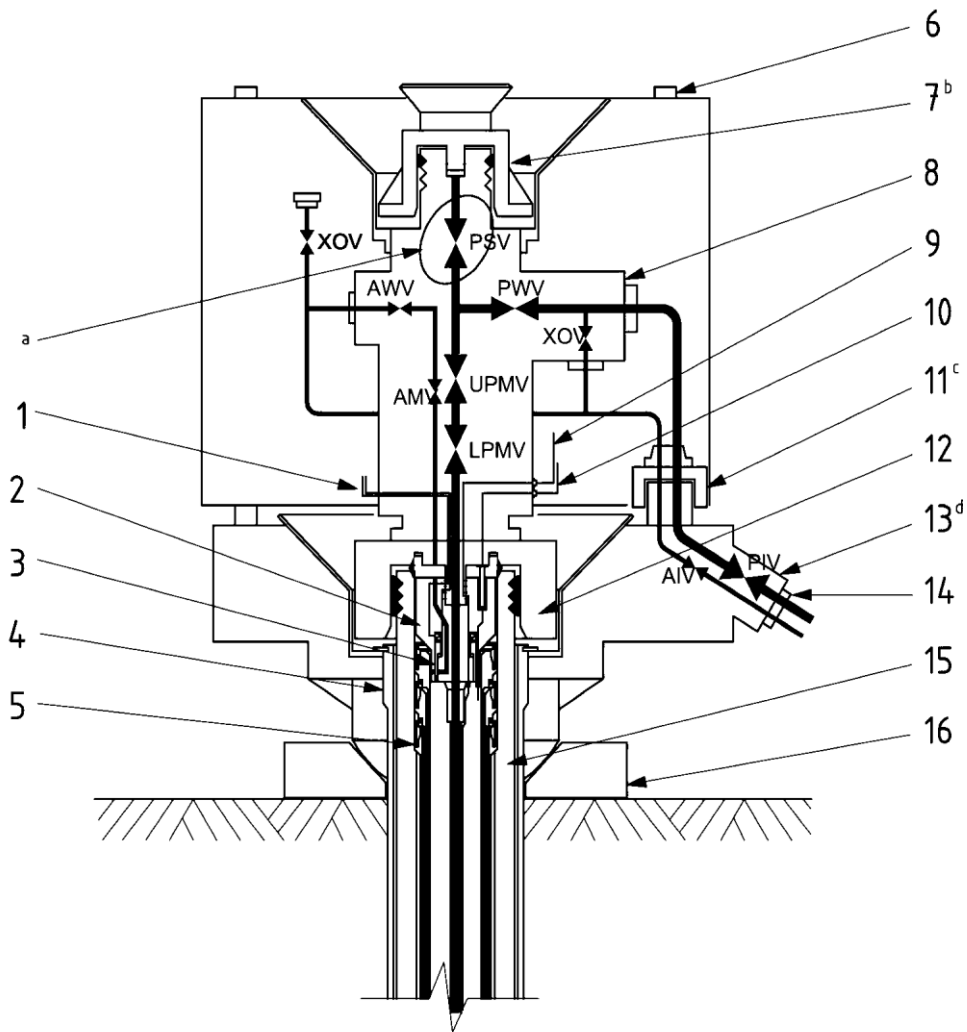

Fig. 3

Concentric-type vertical X-mas tree (VXT):

- 1 — annulus access shift valve control line;
 - 2 — tubing hanger (TH);
 - 3 — annulus access sliding sleeve;
 - 4 — conductor housing;
 - 5 — casing hangers and seal assemblies;
 - 6 — guideposts (optional);
 - 7 — XT cap;
 - 8 — WHA;
 - 9 — downhole pressure temperature transmitter (DHPTT) monitoring line;
 - 10 — surface-controlled subsurface safely valve (SCSSV) control line;
 - 11 — flowline connector,
 - 12 — XT connective fitting;
 - 13 — guidebase;
 - 14 — flowline/tie-in tubing spool connector;
 - 15 — wellhead;
 - 16 — drilling guidebase or template slot;
- a — production swab valve (PSV) and annulus swab valve (ASV) may be substituted with plugs;
 b — XT cap may be pressure-containing or non-pressure-containing;
 c — flowline connection shown connected to production guidebase, but may also be connected directly to WHA;
 d — production guidebase shown (allows connection of flowlines)

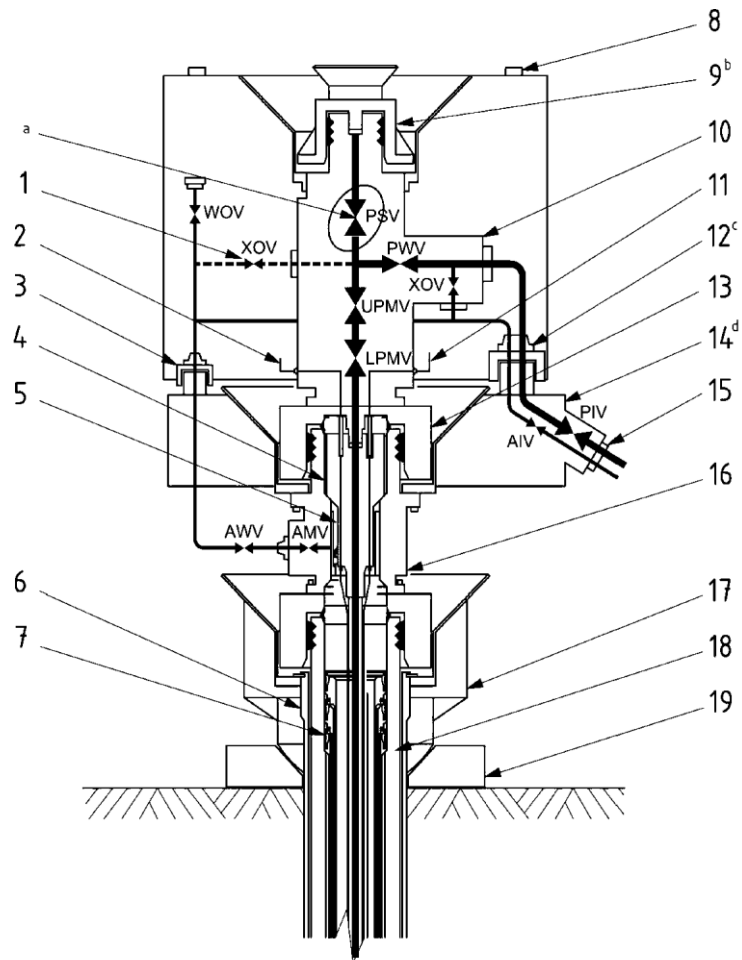

Fig. 4

Concentric-type vertical X-mas tree (VXT) with tubing spool:

- 1 — alternative position of cross-over valve (XOV);
- 2 — surface-controlled subsurface safety valve (SCSSV) control line;
- 3 — annulus connective fitting;
- 4 — tubing hanger (TH);
- 5 — orientation sleeve;
- 6 — conductor housing;
- 7 — casing hangers and seal assemblies;
- 8 — guideposts (optional);
- 9 — XT cap;
- 10 — WHA;
- 11 — downhole pressure temperature transmitter monitoring line;
- 12 — flowline connector;
- 13 — XT connective fitting;
- 14 — guidebase;
- 15 — flowline/tie-in spool connector;
- 16 — tubing spool;
- 17 — XT guidebase;
- 18 — wellhead;
- 19 — drilling guidebase or template slot;
- a — production swab valve (PSV) and annulus swab valve (ASV) may be substituted with plugs;
- b — XT cap may be pressure-containing or non-pressure-containing;
- c — flowline connection shown connected to production guidebase, but may also be connected directly to WHA;
- d — production guidebase shown (allows connection of flowlines)

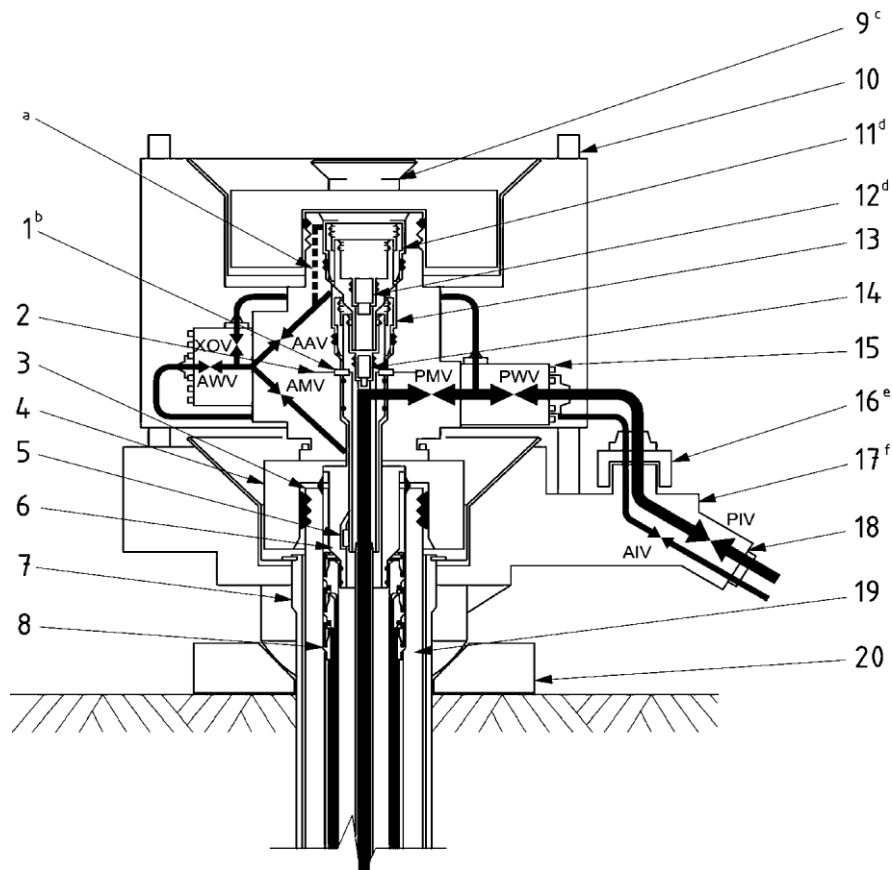

Fig. 5
Horizontal X-mas tree (HXT):

- 1 — horizontal stroking fittings;
- 2 — SCSSV and DHPTT lines;
- 3 — wellhead;
- 4 — XT connective fittings;
- 5 — TH orientation helix;
- 6 — completion stab sleeve;
- 7 — conductor housing;
- 8 — casing hangers and seal assemblies;
- 9 — XT cap;
- 10 — guideposts (optional);
- 11 — internal tree cap (ITC);
- 12 — ITC plug;
- 13 — tubing hanger (TH);
- 14 — TH plug;
- 15 — X-mas tree (XT);
- 16 — flowline connective fitting;
- 17 — guidebase;
- 18 — flowline/tie-in spool connective fitting;
- 19 — wellhead;
- 20 — drilling guidebase or template slot;
- a — permits annulus access without having to remove ITC;
- b — hydraulic/CL lines may be made up with static seal mechanisms;
- c — XT cap may be pressure-containing or non-pressure-containing;
- d — ITC shown with plug. ITC may also be blind or fitted with ball valve;
- e — flowline connection shown connected to production guidebase, but may also be connected directly to WHA;
- f — production guidebase shown (allows connection of flowlines)

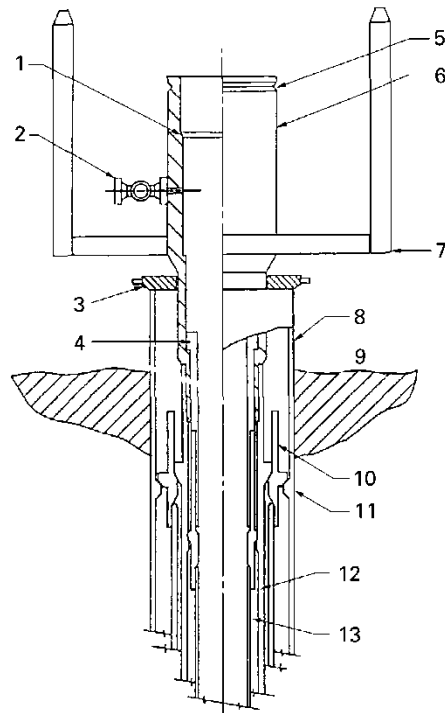

Fig. 6

Typical mudline system with wellhead adaptor for casing adaptors installed:

- 1 — TH profile;
- 2 — annulus outlet;
- 3 — structural support ring (optional);
- 4 — casing hanger tieback adaptor;
- 5 — connective fitting profile;
- 6 — wellhead adaptor;
- 7 — guideline structure;
- 8 — conductor casing;
- 9 — mudline;
- 10 — casing hanger;
- 11 — landing ring;
- 12 — casing hanger;
- 13 — casing hanger

SCHEMATIC DIAGRAMS OF MONITORING, CONTROL AND EMERGENCY SHUTDOWN SYSTEMS

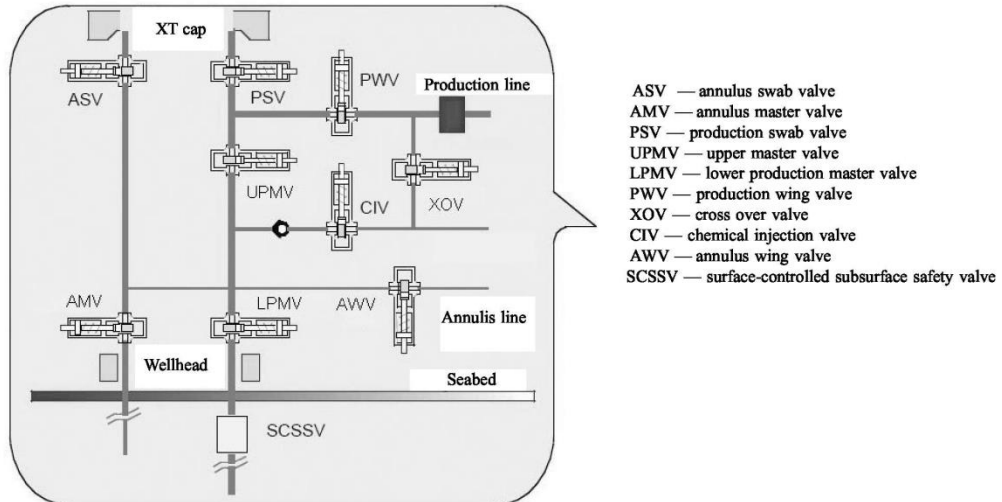

Fig. 1
 Typical set of equipment and valves

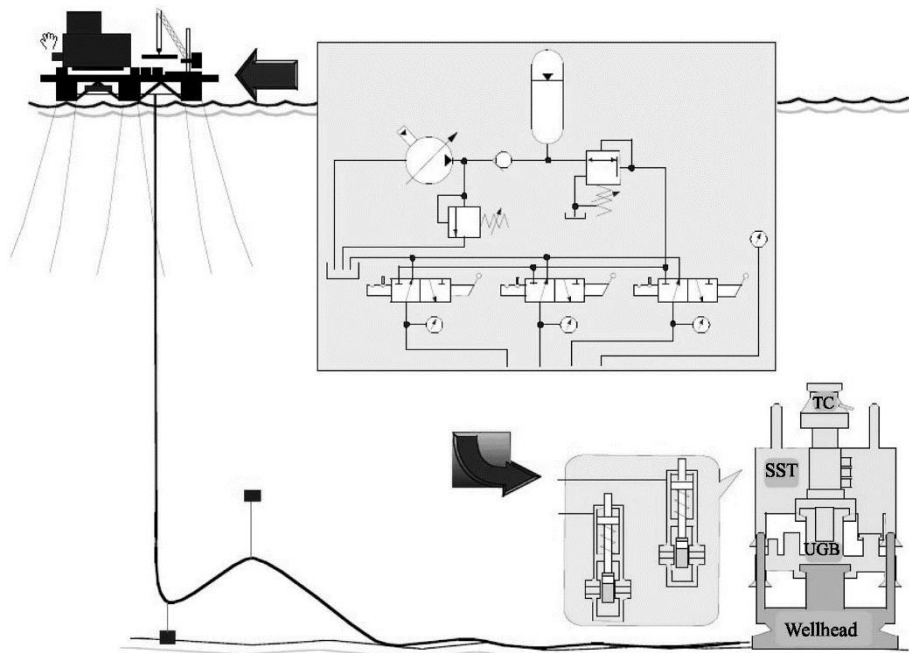

Fig. 2
 Direct hydraulic system

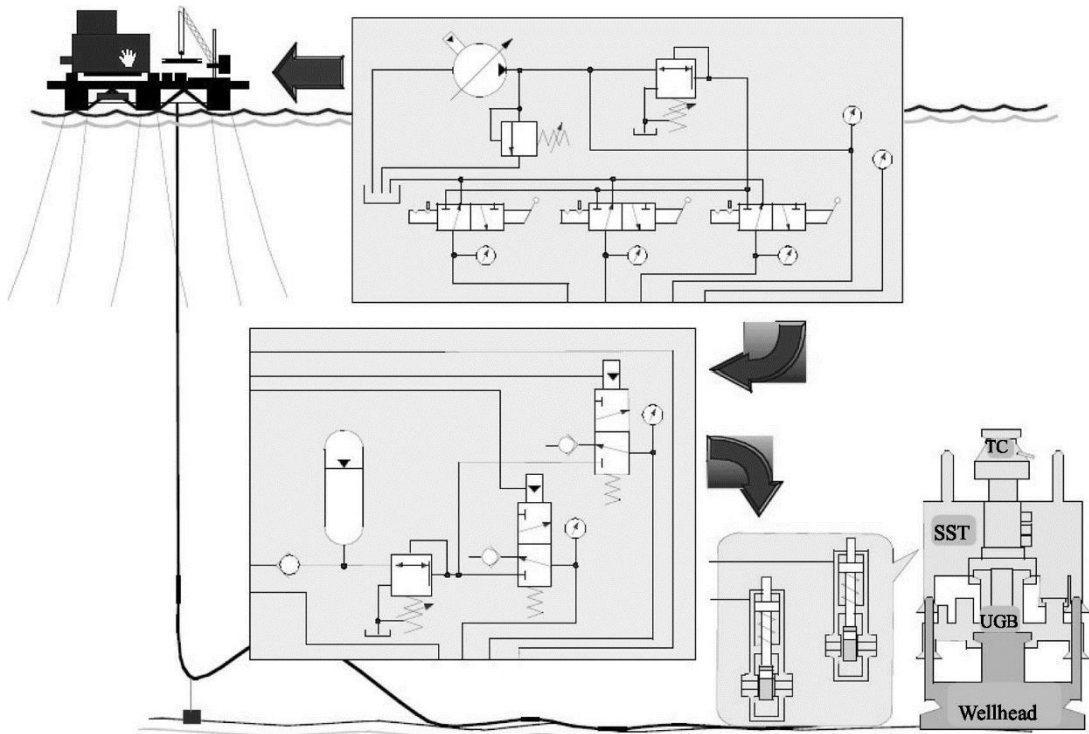

Fig. 3
Hydraulic systems with subsea control module

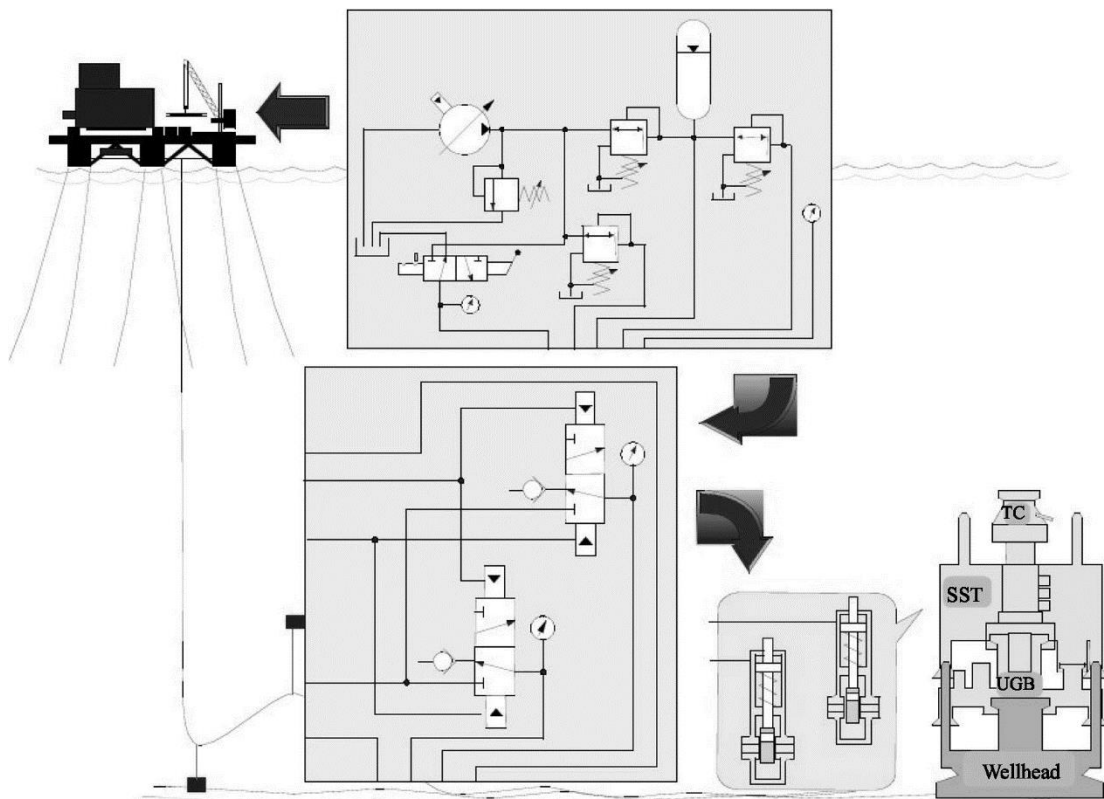

Fig. 4
Hydraulic systems with sequential control

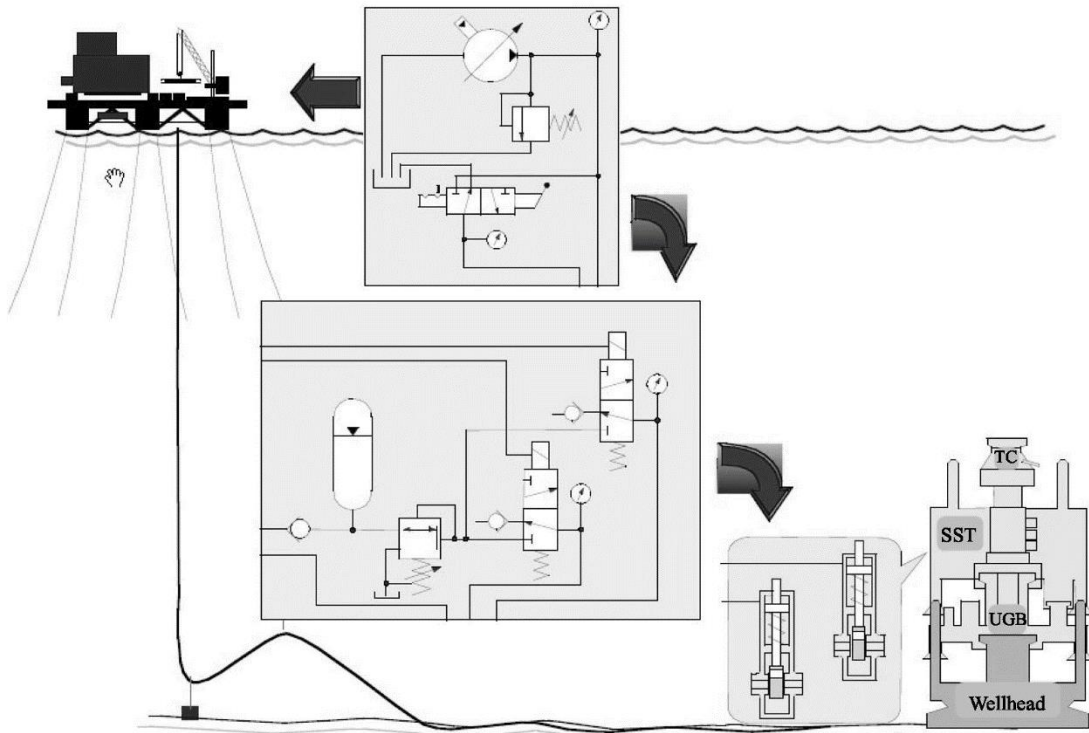

Fig. 5
Directly actuated electrohydraulic systems

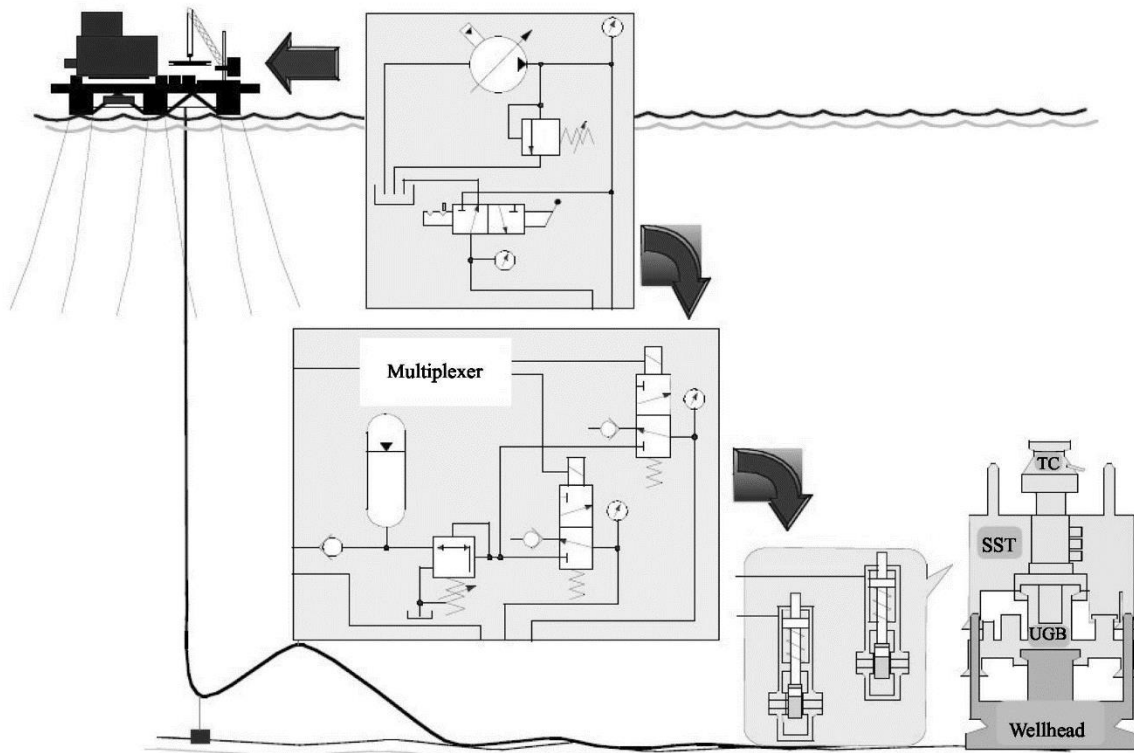

Fig. 6
Multiplex systems

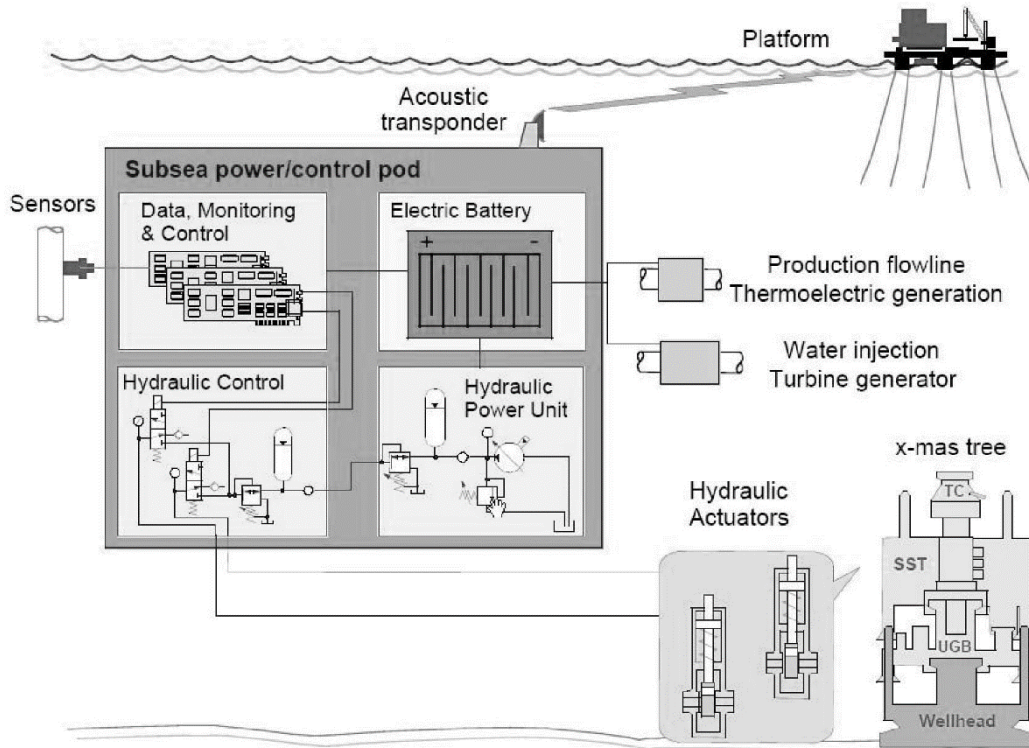

Fig. 7
Subsea Powered Autonomous Control Systems (SPARCS)

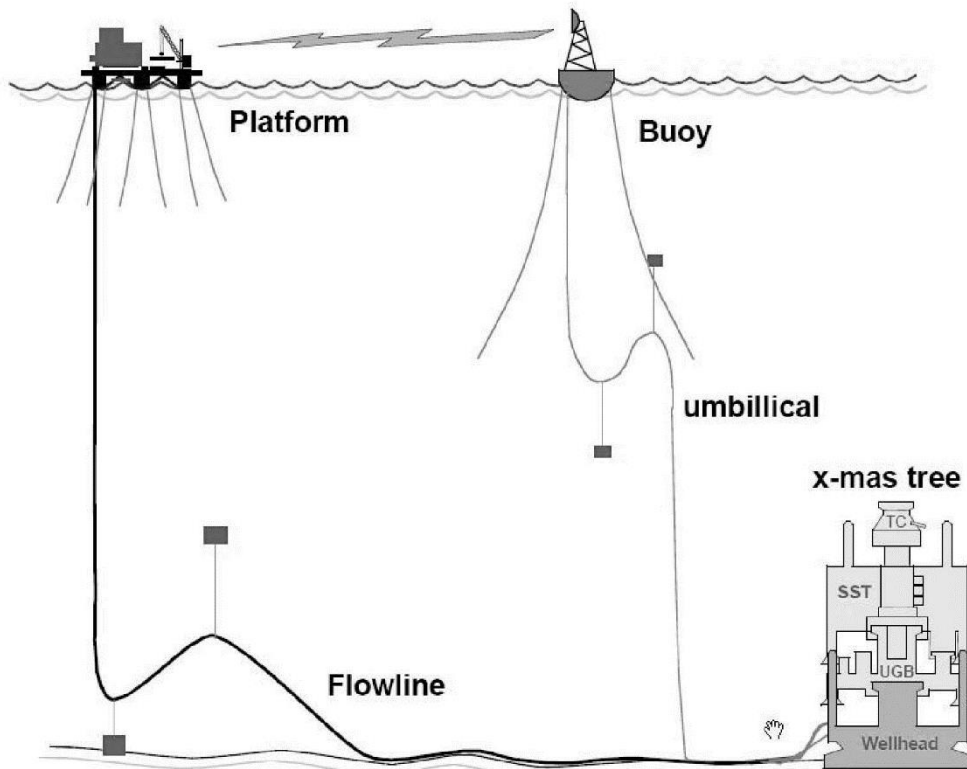

Fig. 8
Integrated control buoys (ICB)

POSSIBLE LEAKAGES FROM SUBSEA WELLHEAD EQUIPMENT

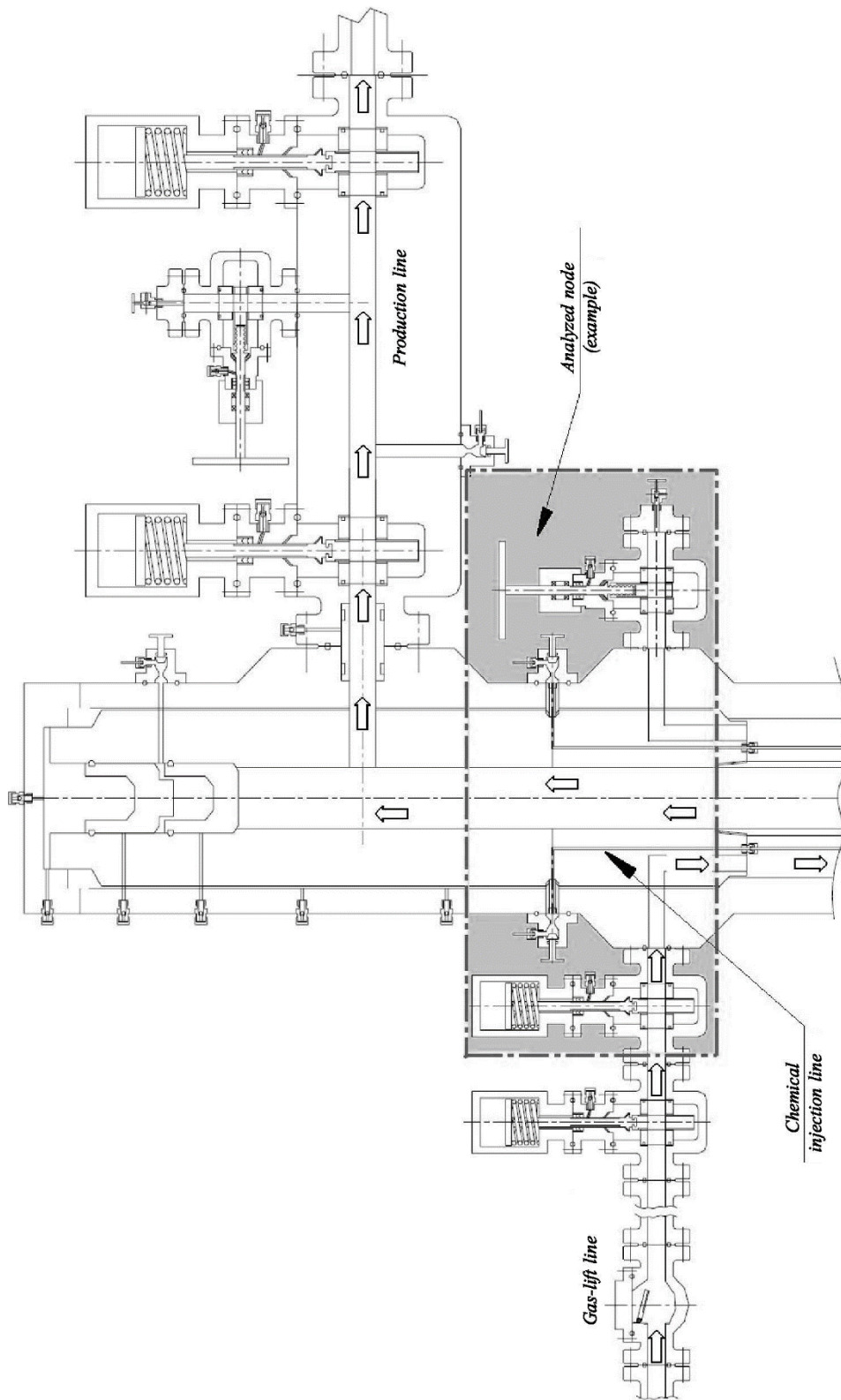

Fig. 1
Example of wellhead setup

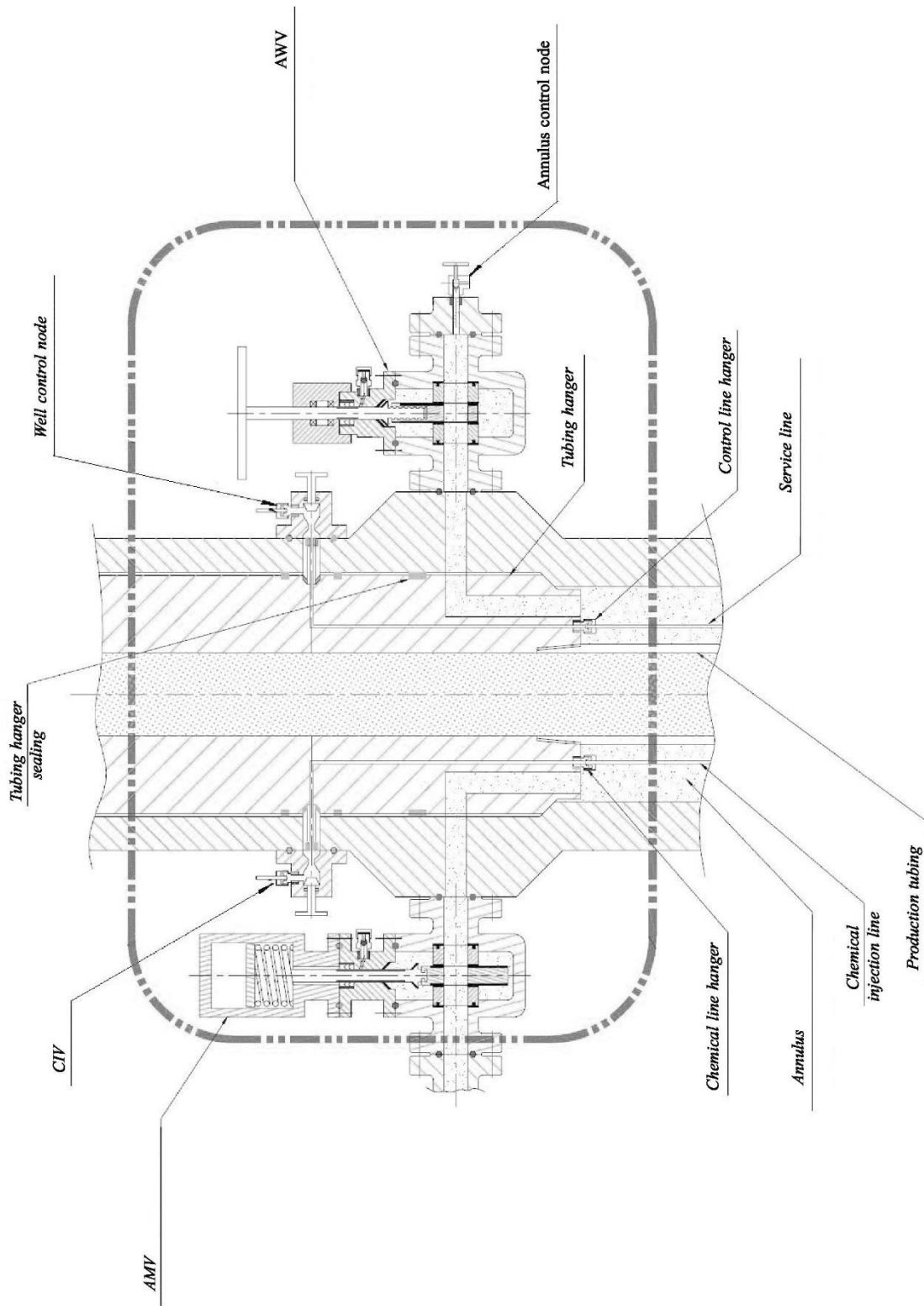

Fig. 2
Example of leakage risk assessment

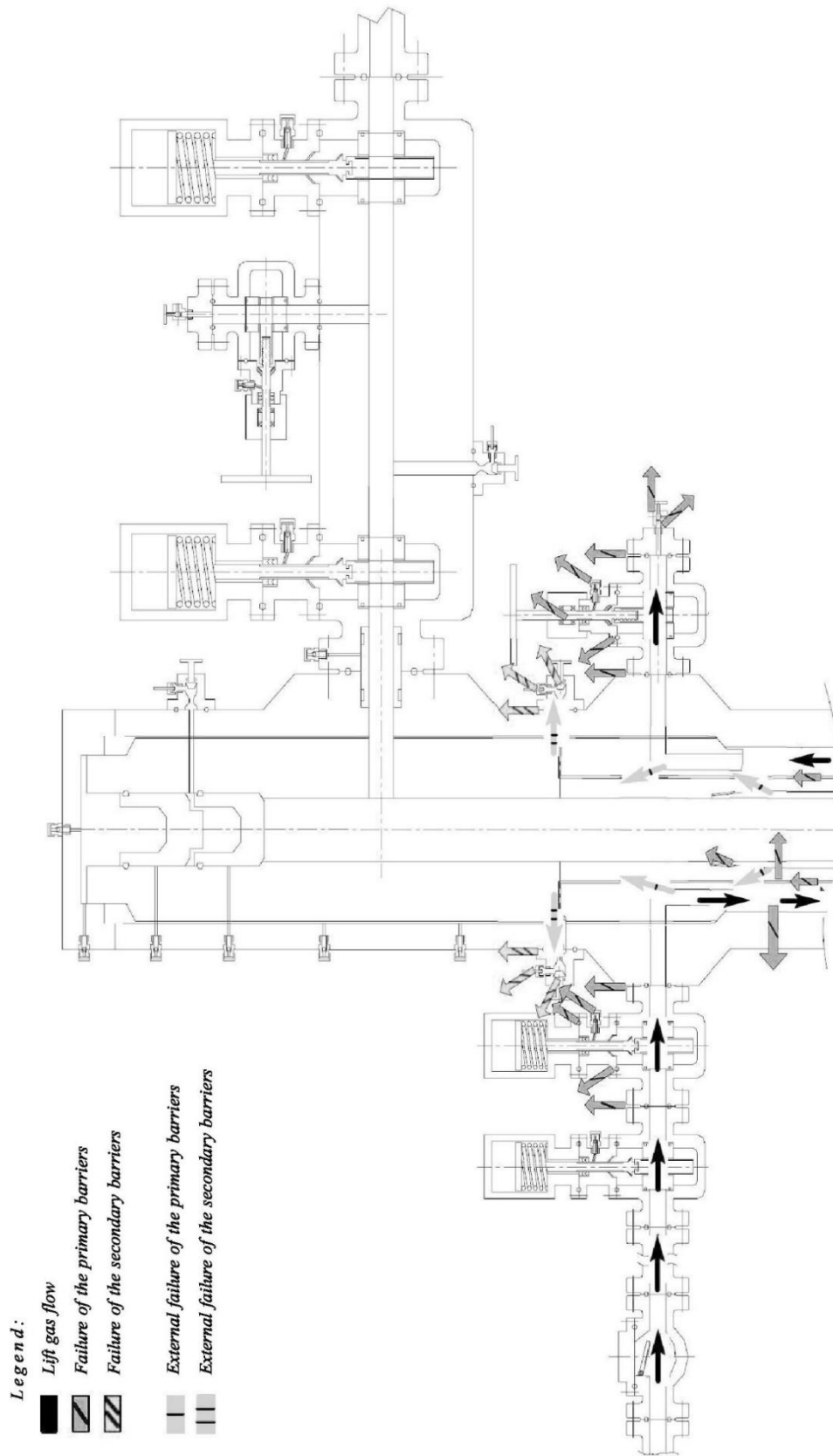

Fig. 3
Nature and direction of possible leakages in assessing risk of leakages

LIST OF RECOGNIZED STANDARD TECHNICAL DOCUMENTS

1. GOST R ISO 13628-4-2016 Petroleum and natural gas industries. Design and operation of subsea production systems. Part 4. Subsea wellhead and tree equipment;
2. GOST 33005-2014 (ISO 13625:2002) Petroleum and natural gas industries. Drilling and production equipment. Marine drilling riser couplings. General technical requirements;
3. GOST R 51365-2009 (ISO 10423:2009) Petroleum and natural gas industries. Drilling and production equipment. Wellhead and Christmas tree equipment. General technical requirements;
4. GOST R 54382-2021 Petroleum and natural gas industry. Subsea pipeline systems. General technical requirements;
5. GOST R 59299-2021 (ISO 13628-3:2000) Petroleum and natural gas industries. Design and operation of subsea production systems. Part 3. Through flowline (TFL) systems;
6. GOST R 59305-2021 (ISO 13628-1:2005) Petroleum and natural gas industries. Design and operation of subsea production systems. Part 1. General requirements and recommendations;
7. GOST R 59306-2021 Petroleum and natural gas industries. Design and operation of subsea production systems. Part 10. Specification for bonded flexible pipe;
8. GOST R 59307-2021 Petroleum and natural gas industries. Design and operation of subsea production systems. Part 16. Specification for flexible pipe ancillary equipment;
9. GOST R 59308-2021 Petroleum and natural gas industries. Design and operation of subsea production systems. Part 17. Guidelines for bonded flexible pipes auxiliary installations;
10. GOST R 59309-2021 Petroleum and natural gas industries. Design and operation of subsea production systems. Part 2. Unbounded flexible pipe systems for subsea and marine applications;
11. GOST R 70842-2023 (ISO 13628-8:2002) Petroleum and natural gas industries. Design and operation of subsea production systems. Part 8. Remotely operated vehicle (ROV) interfaces on subsea production systems;
12. GOST R 70843-2023 Petroleum and natural gas industries. Design and operation of subsea production systems. Part 9. Remotely operated tool (ROT) intervention systems;
13. GOST R 70799-2023 Petroleum and natural gas industries. Design and operation of subsea production systems. Part 14. Subsea high integrity pressure protection system;
14. GOST R 71121-2023 (ISO 13628-11:2007) Petroleum and natural gas industries. Design and operation of subsea production systems. Part 11. Flexible pipe systems for subsea and marine applications;
15. GOST R 71122-2023 (ISO 13628-15:2011) Petroleum and natural gas industries. Design and operation of subsea production systems. Part 15. Subsea structures and manifolds;
16. GOST R 71160-2023 (ISO 13628-6:2006) Petroleum and natural gas industries. Design and operation of subsea production systems. Part 6. Subsea production control systems;
17. GOST R 71204-2024 (ISO 13628-5:2009) Petroleum and natural gas industries. Design and operation of subsea production systems. Part 5. Subsea control umbilicals;
18. GOST R 71205-2024 Petroleum and natural gas industries. Design and operation of subsea production systems. Part 7. Completion/workover riser systems;
19. ISO 12736-1:2023 Oil and gas industries including lower carbon energy — Wet thermal insulation systems for pipelines and subsea equipment Part 1: Validation of materials

and insulation systems;

20. ISO 12736-2:2023 Oil and gas industries including lower carbon energy — Wet thermal insulation systems for pipelines and subsea equipment Part 2: Qualification processes for production and application procedures;

21. ISO 12736-3:2023 Oil and gas industries including lower carbon energy — Wet thermal insulation systems for pipelines and subsea equipment Part 3: Interfaces between systems, field joint systems, field repairs and pre-fabricated insulation;

22. ISO 13628-1:2005/Amd 1:2005 Petroleum and natural gas industries — Design and operation of subsea production systems — Part 1: General requirements and recommendations;

23. ISO 13628-2:2006/Cor 1:2009 Petroleum and natural gas industries — Design and operation of subsea production systems — Part 2: Unbonded flexible pipe systems for subsea and marine applications;

24. ISO 13628-4:2010/Cor 1:2011 Petroleum and natural gas industries — Design and operation of subsea production systems — Part 4: Subsea wellhead and tree equipment;

25. ISO 13628-5:2009 Petroleum and natural gas industries — Design and operation of subsea production systems — Part 5: Subsea umbilicals;

26. ISO 13628-6:2006 Petroleum and natural gas industries — Design and operation of subsea production systems — Part 6: Subsea production control systems;

27. ISO 13628-7:2005 Petroleum and natural gas industries — Design and operation of subsea production systems — Part 7: Completion/workover riser systems;

28. ISO 13628-8:2002/Cor 1:2005 Petroleum and natural gas industries — Design and operation of subsea production systems — Part 8: Remotely Operated Vehicle (ROV) interfaces on subsea production systems;

29. ISO 13628-9:2000 Petroleum and natural gas industries — Design and operation of subsea production systems — Part 9: Remotely Operated Tool (ROT) intervention systems;

30. ISO 13628-10:2005 Petroleum and natural gas industries — Design and operation of subsea production systems — Part 10: Specification for bonded flexible pipe;

31. ISO 13628-11:2007/Cor 1:2008 Petroleum and natural gas industries — Design and operation of subsea production systems — Part 11: Flexible pipe systems for subsea and marine applications;

32. ISO 13628-15:2011 Petroleum and natural gas industries — Design and operation of subsea production systems — Part 15: Subsea structures and manifolds;

33. ISO 19906:2010 Petroleum and natural gas industries — Arctic offshore structures;

34. ISO 10423:2009 Petroleum and natural gas industries — Drilling and production equipment — Wellhead and Christmas tree equipment;

35. ISO 4406:1999 Hydraulic fluid power — Fluids — Method for coding the level of contamination by solid particles.

Russian Maritime Register of Shipping

**Rules for the Classification and Construction
of Subsea Production Systems**

FAI "Russian Maritime Register of Shipping"

7, Litera A, Millionnaya Ulitsa

St. Petersburg, 191186

Russian Federation

www.rs-class.org/en/