

RULES

FOR THE CLASSIFICATION AND CONSTRUCTION OF MOBILE OFFSHORE DRILLING UNITS

PART X ELECTRICAL EQUIPMENT

ND No. 2-020201-026-E



St. Petersburg

RULES FOR THE CLASSIFICATION AND CONSTRUCTION OF MOBILE OFFSHORE DRILLING UNITS (PART X)

The present version of Part X "Electrical Equipment" of the Rules for the Classification and Construction of Mobile Offshore Drilling Units in Bulk of Russian Maritime Register of Shipping (RS, the Register) has been approved in accordance with the established approval procedure and comes into force on 1 January 2026.

The present version is based on the version dated 1 January 2024 and Rule Change Notice No. 25-251443 taking into account the amendments and additions developed immediately before publication (refer to the [Revision History](#)).

REVISION HISTORY¹

For this version, there are no amendments to be included in the Revision History.

¹ With the exception of amendments and additions introduced by Rule Change Notices (RCN), as well as of misprints and omissions.

1 GENERAL

1.1 APPLICATION

1.1.1 The requirements of this Part of the Rules for the Classification and Construction of Mobile Offshore Drilling Units¹ apply to the electrical equipment of machinery installations (powerplants) as well as to systems and appliances of mobile offshore drilling units being subject to the technical supervision of the Register, and also to individual types of the electrical equipment according to [1.3](#).

1.1.2 The applicable requirements of this Part shall be also applied to the fixed electrical equipment not mentioned in [1.3](#), but potentially affecting the operation of essential machinery and appliances in case of their malfunctions or accidents.

¹ Hereinafter referred to as "the MODU Rules".

1.2 DEFINITIONS AND EXPLANATIONS

1.2.1 Definitions and explanations relating to the general terminology of the MODU Rules are given in the General Regulations for the Classification and Other Activity.

For the purpose of this Part, the following definitions have been adopted.

Emergency lighting is lighting of MODU spaces and zones by means of lighting fixtures fed from an emergency source of power or from the transitional emergency source of power.

Emergency source of electrical power is a source of electrical power intended to supply necessary unit's services in case of power failure on the main switchboard.

Emergency transitional source of electrical power is a source of electrical power intended to supply necessary unit's services from the moment of the power failure on the main switchboard busbars until the emergency generator is switched on to supply the emergency switchboard busbars.

Valve-regulated sealed type battery (sealed battery) is a sealed unattended accumulator battery with recombination of issued gases giving off no gases in operation outside the case.

Safety voltage is any voltage not dangerous to the personnel. This condition is considered to be satisfied if the windings of transformers, converters and other devices to step down voltage are electrically separated, and if the value of stepped down voltage across those devices or sources of electrical power does not exceed:

50 V between poles for direct current;

50 V between phases or between phases and the unit's hull for alternating current.

Main machinery of MODU is prime movers of generators of the MODU main source of electrical power.

Earthing is deliberate electrical connection of the part of the electrical equipment to be earthed to the unit's hull, which has a resistance not more than 0,2 ohm.

Enclosed spaces are locations limited by partitions and/or decks and bulkheads that may have doors or windows.

Lightning protection zone is the area within the limits of which the unit's space is protected against direct lightning strokes.

MODU hull is all MODU metal parts having reliable electrical connection to the outer metal shell plating.

Air termination network is the upper part of the lightning protective device intended for the perception of atmospherics.

Minimum comfortable conditions of habitability on board the MODU are the conditions under which it is ensured the operation of electrical auxiliary machinery and arrangements for:

lighting;

cooking;

heating;

preservation of provisions (domestic refrigerating equipment);

forced ventilation systems;

sanitary water supply;

fresh water supply.

Non-essential services are the electrical equipment the temporary disconnection of which does not impair the level of MODU safety, the safety of human life and environmental safety.

Main source of electrical power is a source of electrical power intended to supply all the electrical machinery, equipment and systems essential for maintaining the MODU in normal operational and habitable conditions without resorting to the emergency source of electrical power.

Essential services are the electrical equipment the normal operation of which ensures the safety of MODU operation, safety of human life and the environmental safety. These services include the ones listed in [1.3.2.1](#).

Semi-enclosed spaces are locations with natural ventilation conditions differing from those at the exposed decks due to such structures as partitions, wind deflectors and bulkheads arranged in the way that gas dispersion may not occur.

Control stations are rooms and spaces, which incorporate the following equipment and arrangements (as a complete or incomplete set):

- control and normal shut-down systems for process machinery and arrangements;
- emergency shut-down systems for machinery and arrangements (including process machinery and arrangements);

- control panel of the main source of electrical power;

- control panel of auxiliary machinery and remote- controlled pipeline valves;

- radiocommunication and intercommunication systems including a general alarm system;

- main fire alarm station and an explosive gas concentration detection and alarm system;

- remote control station of fire-smothering means;

- direct control station of fire-smothering means;

- control station of an emergency source of electrical power.

Special electrical rooms are locations intended expressly for electrical equipment and accessible to attending personnel only.

1.3 SCOPE OF TECHNICAL SUPERVISION

1.3.1 General.

General provisions applicable to the classification procedure, technical supervision during MODU construction and equipment manufacture, and to surveys are stated in Part I "Classification" of the MODU Rules.

1.3.2 Technical supervision of electrical equipment on board the MODU.

1.3.2.1 The following kinds of essential equipment, systems and arrangements are subject to technical supervision on board the MODU:

- .1 electric propulsion plant of a self-propelled MODU, and electrical and electronic equipment of dynamic positioning systems;
- .2 main, emergency and emergency transitional sources of electrical power, and also the sources of continuous electrical power supply for essential systems;
- .3 power transformers and converters used in the equipment, systems and arrangements listed in [1.3.2.1](#);
- .4 distribution boards, and control and monitoring desks and panels;
- .5 electric drives of auxiliaries serving main machinery operation, drives of:
jacking mechanisms of self-elevating MODU;
steering gear;
CP-propellers;
thrusters;
pumps of submersion and emersion systems of semi-submersible MODU;
submersible pumps of self-elevating MODU, and of arrangements for lifting sea water piping of those pumps;
anchor and mooring machinery;
launching devices for lifeboats and liferafts;
starting air, control system and sound signal air compressors;
bilge and ballast pumps;
pumps and arrangements of fire-extinguishing systems;
mechanisms of watertight and fire-proof doors;
fans in machinery spaces, cofferdams, accommodation and service spaces;
fans in hazardous spaces and areas;
fans of equipment having the degree of protection as "pressurized enclosure";
- .6 main and emergency lighting of spaces and locations of essential services, of escape routes, and low location emergency lighting;
- .7 clearance, navigation and flashing lights;
- .8 electric engine-room telegraphs of self-propelled MODU;
- .9 service telephone and loud-speaking communication;
- .10 general alarms;
- .11 fire detection and fire alarm system, and a system warning of the release of fire-smothering medium; systems for detection and alarm of the high concentrations of explosive vapours and gases, of the malfunction of hazardous space ventilation systems and of pressurized electrical equipment, of the malfunction of self-elevating MODU jacking system;
- .12 indicating systems of the position of:
watertight and fire doors;
remote-controlled valves of MODU submersion and emersion systems;
self-elevating MODU legs on sea bed;
FOP base;
- .13 electrical equipment in hazardous locations and spaces;
- .14 cable network;
- .15 MODU hull earthing facilities;
- .16 lightning protection;

- .17 electric drives of classified refrigerating machinery;
- .18 electric fuel and oil heaters;
- .19 stationary electrical heating and cooking appliances;
- .20 starting equipment, protective devices, control gear and switchgear;
- .21 other machinery and equipment not listed above as required by the Register.

1.3.2.2 Electrical equipment of domestic services, process equipment and the electrical equipment of machinery, systems and arrangements directly intended for drilling wells and not listed in [1.3.2.1](#) is subject to technical supervision on board the MODU only in respect to:

- .1 influence exerted by the operation of this equipment on the quality of electrical power produced by the electrical power plant;
- .2 selection of the types and sections of cables and wires, as well as the methods of cable installation;
- .3 insulation resistance, earthing and protective devices.

In addition, the technical supervision shall be carried out in compliance with the requirements of this Part with regard to fulfilment of the requirements on the explosion-proof type of electrical equipment in hazardous spaces and zones.

1.3.3 Technical supervision during manufacture of electrical equipment for MODU.

1.3.3.1 The following kinds of electrical equipment intended for use in installations and systems listed in [1.3.2.1](#) are subject to technical supervision during manufacture:

- .1 generator sets;
- .2 electrical machines;
- .3 transformers;
- .4 switchboards;
- .5 control and monitoring panels;
- .6 electric slip couplings and brakes;
- .7 apparatus and devices for electrical protection, starting, control and switching;
- .8 apparatus and devices of internal communication and signalling;
- .9 power semiconductor converters and other similar power units;
- .10 fuel and oil heaters;
- .11 accumulator batteries;
- .12 cables and wires;
- .13 fixed electrical measuring instruments;
- .14 electrical apparatus and facilities to measure non-electrical values;
- .15 space heating and cooling appliances;
- .16 lighting switches and accessories;
- .17 stationary lighting fixtures and searchlights;
- .18 electrical equipment of dynamic positioning systems;
- .19 other kinds of the electrical equipment not listed above as required by the Register.

1.3.3.2 The explosion-proof electrical equipment shall be supervised (as to its safety) by a competent organization whose documents are recognized by the Register, irrespective of whether or not this equipment is subject to technical supervision according to the requirements of [1.3.3.1](#).

1.3.3.3 The scope and standards of electrical equipment tests after manufacture are specified in Section 10, Part IV "Technical Supervision during Manufacture of Products" of the Rules for Technical Supervision during Construction of Ships and Manufacture of Materials and Products for Ships¹. For machinery and gear of non-essential services the equipment of general commercial type may be used.

¹ Hereinafter referred to as "the Rules TSDCS".

1.4 TECHNICAL DOCUMENTATION

1.4.1 General provisions applicable to the procedure of technical documentation approval by the Register are set forth in the General Regulations for the Classification and Other Activity. The scope of technical documentation on electrical equipment for the entire unit to be submitted to the Register for consideration is stated in Part I "Classification" of the MODU Rules.

1.4.2 Prior to the technical supervision of electrical equipment manufacture, the following documentation on each kind of equipment shall be submitted to the Register for consideration:

- .1** description of the principle of operation and main characteristics of the equipment;
- .2** specification (list of items), which specifies all the components, instruments and materials used and their technical characteristics;
- .3** general view drawings with sectional views;
- .4** circuit diagrams;
- .5** test program;
- .6** results of rotor shaft (armature) calculation; drawing of poles fastening, active iron core, commutator, etc., as well as of welded joints of a structure and shaft for electrical machines with rated current in excess of 1000 A;
- .7** busbar calculation for dynamic and thermal short circuit stability (for switchboards if the rated current of generators operating separately or the total current of generators operating in parallel exceeds 1000 A);
- .8** data on dynamic and static interference immunity or method of electromagnetic compatibility testing;
- .9** measures to be taken for interference suppression;
- .10** drawings of electrical equipment layout in hazardous areas with indication of the kind of explosion protection, the type of used cables, their cross-sections and components of junction boxes;
- .11** electrical diagrams of explosion-proof type equipment, diagrams of circuits relating to them, documentation witnessing the explosion protection type;
- .12** drawings and specification of the electrical equipment having the explosion protection type "pressurized enclosure", an alarm system of excessive air pressure loss and the relevant diagrams.

2 GENERAL REQUIREMENTS

The electrical installation of a MODU shall be such as to ensure:

- supply of all electrical machinery and arrangements maintaining normal operation of the MODU, including normal habitable conditions for personnel without the use of an emergency source of electrical power, from a main source of electrical power;
- supply of essential services and arrangements, which ensure the MODU safety, from an emergency source of electrical power during the given period of time if a main source of electrical power fails;
- the safety of the crew and installation as a whole under the conditions of MODU normal and emergency operation.

2.1 OPERATING CONDITIONS

2.1.1 Climatic conditions.

2.1.1.1 The rated ambient air and cooling water temperatures for electrical equipment shall be those specified in [Table 2.1.1.1](#).

Table 2.1.1.1

Nos.	Equipment location	Ambient air and cooling water temperature, °C			
		Unrestricted service		Navigation outside the tropical zone	
		air	water	air	water
1	Machinery and special electrical spaces, galleys	+45 – 0	+ 32	+40 – 0	+ 25
2	Service, accommodation and other spaces	+45 – 0		+40 – 0	
3	Weather decks	+45 – -25 ¹		+40 – -25 ¹	

¹ The working temperature for electrical equipment installed on exposed decks shall be consistent with the MODU operational area.

Note. Electric and electronic componentry and devices designed for mounting in switchboards, panels and cabinets shall be capable of reliable performance at an ambient air temperature up to 55 °C. Temperature up to 70 °C shall not lead to the failure of the elements, devices and systems.

2.1.1.2 Electrical equipment shall be capable of reliable performance at a relative air humidity of $75 \pm 3 \%$ and a temperature of $+ 45 \pm 2 \text{ }^\circ\text{C}$ or at a relative air humidity of $80 \pm 3 \%$ and a temperature of $+40 \pm 2 \text{ }^\circ\text{C}$, and also at a relative air humidity of $95 \pm 3 \%$ and a temperature of $+ 25 \pm 2 \text{ }^\circ\text{C}$.

The electrical equipment installed on MODU exposed decks when used in areas of a cold climate shall reliably operate at a relative air humidity of 85 % and a temperature of $- 6 \text{ }^\circ\text{C}$.

2.1.1.3 The structural parts of electrical equipment shall be made of materials resistant to sea air or reliably protected against such effects.

2.1.1.4 Where electrical equipment is installed within environmentally controlled spaces the ambient temperature, for which the equipment shall be suitable, may be reduced from $45 \text{ }^\circ\text{C}$ down to $35 \text{ }^\circ\text{C}$, provided:

- the equipment is not for use for emergency services and is located outside the machinery spaces;

- temperature control is achieved by at least two cooling units so arranged that in the event of loss of one cooling unit, the remaining unit is capable of satisfactorily maintaining the design temperature;

the equipment shall be able to work safely at temperature of +45 °C until the nominal working ambient temperature may be achieved; the cooling units shall be rated for + 45 °C ambient temperature;

audible and visual alarms shall be provided at a continually manned control station to indicate any malfunction of the cooling units.

2.1.1.5 For the equipment with allowable ambient temperature less than 45 °C, provision shall be made that supply cables of such equipment were rated for the maximum ambient temperature which might be recorded (or expected) during installation over the whole length of cable.

2.1.1.6 The equipment installed for cooling and maintaining the lower ambient temperature (for the equipment specified in [2.1.1.4](#) and [2.1.1.5](#)) shall be classified as an essential equipment and be subject to the Register technical supervision in compliance with the requirements of the MODU Rules.

2.1.2 Mechanical effects.

2.1.2.1 Electrical equipment shall be capable of reliable performance at vibrations with frequency of 2 to 80 Hz, i.e. with an amplitude of displacements of ± 1 mm for frequency range of 2 to 13,2 Hz and an acceleration of $\pm 0,7g$ for frequency range of 13,2 to 80 Hz.

Electrical equipment located on the sources of vibrations (diesel engines, compressors, etc.) or in the steering gear room of a MODU shall be capable of reliable performance at vibrations of 2 to 100 Hz, i.e. with an amplitude of displacement of $\pm 1,6$ mm for frequency range of 2 to 25 Hz and an acceleration of $\pm 4,0g$ for frequency range of 25 to 100 Hz.

Electrical equipment shall also be capable of reliable performance at shocks having an acceleration of $\pm 5,0g$ and at a frequency of 40 to 80 shocks per minute.

2.1.2.2 Electrical equipment shall be capable of reliable performance:

semi-submersible MODU – at a continuous heel of up to 15° and at a short-term heel of up to 22,5° in any direction;

self-elevating MODU – at a continuous heel of up to 10° and at a short-term heel of up to 15° in any direction;

MODU – at a continuous heel of up to 15° and a trim by the bow or stem of up to 5°, and also in rolling up to 22,5° and heaving up to 7,5° out of the vertical.

In addition, emergency electrical equipment shall be capable of functioning reliably:

semi-submersible MODU – at a continuous heel of up to 25° in any direction;

self-elevating MODU – at a continuous heel of up to 15° in any direction;

MODU – at a continuous heel of up to 22,5° and a trim of up to 10°, and also at a simultaneous heel and trim within the above limits.

2.1.2.3 Electrical equipment shall possess the relevant mechanical strength and shall be so located as to avoid the risk of mechanical damage (refer also to [2.7.4](#)).

2.1.3 Permissible variations of supply parameters.

2.1.3.1 Electrical equipment shall be so designed that it remains operative in all cases under steady conditions at all variations from the rated supply voltage and frequency as specified in [Table 2.1.3.1](#) (refer also to [3.1.2.2](#) and [16.8.3.3](#)).

Table 2.1.3.1

Parameters	Variations from rated values		
	for long periods, %	for short periods	
		%	time, s
Voltage (A.C)	+6... -10	±20	1,5
Frequency	±5	±10	5

Note. When the services are fed from accumulator battery:
 long-period voltage variation within + 30 to – 25 % for the equipment fed from the accumulator battery connected to the charging unit;
 long period voltage variation within + 20 to – 25 % for the equipment, which is not connected to the charging unit.

2.1.3.2 In MODU it is allowed to use for machinery and gear of non-essential services the electrical equipment of general commercial type.

2.2 ELECTROMAGNETIC COMPATIBILITY

2.2.1 General.

2.2.1.1 These requirements apply to electrical, automation, radio and navigational equipment of a MODU to ensure electromagnetic compatibility of electrical and electronic equipment of the MODU.

2.2.1.2 Failure-free performance of the equipment shall be ensured under conditions of interference having the following parameters:

- .1 static and variable (50 Hz) magnetic field in accordance with [Table 2.2.1.2.1](#).

Table 2.2.1.2.1

Class of equipment	Intensity, A/m	
	static field	variable field (50 Hz)
1	100	10
2	400	400
3	1000	1000

Installation of equipment is permitted:

class 1 – at a distance of 2 m and more from a powerful field source (busbar, group transformer);

class 2 – at a distance of 1 m and more from a powerful field source;

class 3 – irrespective of the distance from any field source;

.2 harmonic components of voltage in supply circuits in accordance with the higher harmonics diagram for mains to be found in [Fig. 2.2.1.2.2](#) on a logarithmic scale;

.3 electrostatic discharges with a voltage amplitude of 8 kV;

.4 radio frequency electromagnetic fields within the range 80 MHz to 6 GHz with a root-mean-square value of field intensity of 10 V/m;

.5 nanosecond voltage pulses with an amplitude of 2 kV for the power supply circuits and of 1 kV for signal and control cables with the duration of 5/50 ns;

.6 radio frequency interference in conductivity circuits within the range 150 kHz to 80 MHz with a root-mean-square value of voltage 3 V and 80 % modulation at the frequency of 1 kHz;

.7 microsecond voltage pulse with the duration of 1,2/50 μ s in supply circuits with an amplitude of 1 kV when fed via the coupling decoupling device between each circuit and casing and of 0,5 kV when fed via the coupling decoupling device between the circuits.

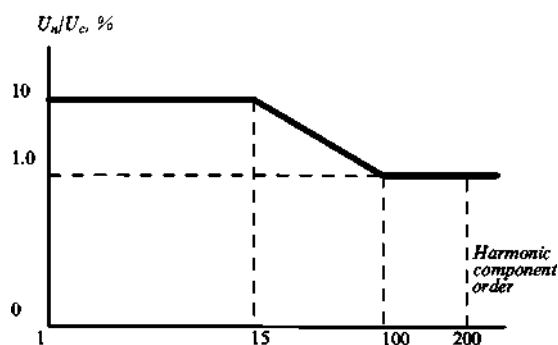

Fig. 2.2.1.2.2

Diagram of higher harmonic components for mains

2.2.1.3 The voltage curve harmonic distortion factor K_u shall not exceed 8 % and shall be determined by the formula

$$K_u = \frac{1}{U_c} \sqrt{\sum_{n=2}^{40} U_n^2} \times 100\% \quad (2.2.1.3)$$

where U_c = actual circuit voltage;
 U_n = harmonic component voltage;
 n = higher harmonic component order.

The K_u value is specified for the complete electrical power system.

Separate busbars with $K_u > 8 \%$ may be used for power supply to powerful sources of harmonic components of voltage and to the electrical equipment not sensitive to such harmonic components provided that the above busbars are connected to the main busbars through filtering or galvanic isolating devices (refer also to [2.2.2.2](#)).

2.2.1.4 The intensity levels of radio interference from the equipment at the electric power supply terminals shall not exceed the values shown in [Fig. 2.2.1.4](#).

2.2.1.5 On MODU, for which the level of radio interference from power semiconductor converters cannot be limited in compliance with [2.2.1.4](#), the mains of automation, radio and navigational equipment shall be galvanically isolated from the mains of those converters so that at least 40 dB are damped within the frequency range 0,01 – 30 MHz.

The power supply cables of equipment having the radio interference levels in excess of those specified in [2.2.1.4](#) shall be laid at least 0,2 m away from the cables of other equipment groups where the common cable run is longer than 1 m (refer to [2.2.2.8](#)).

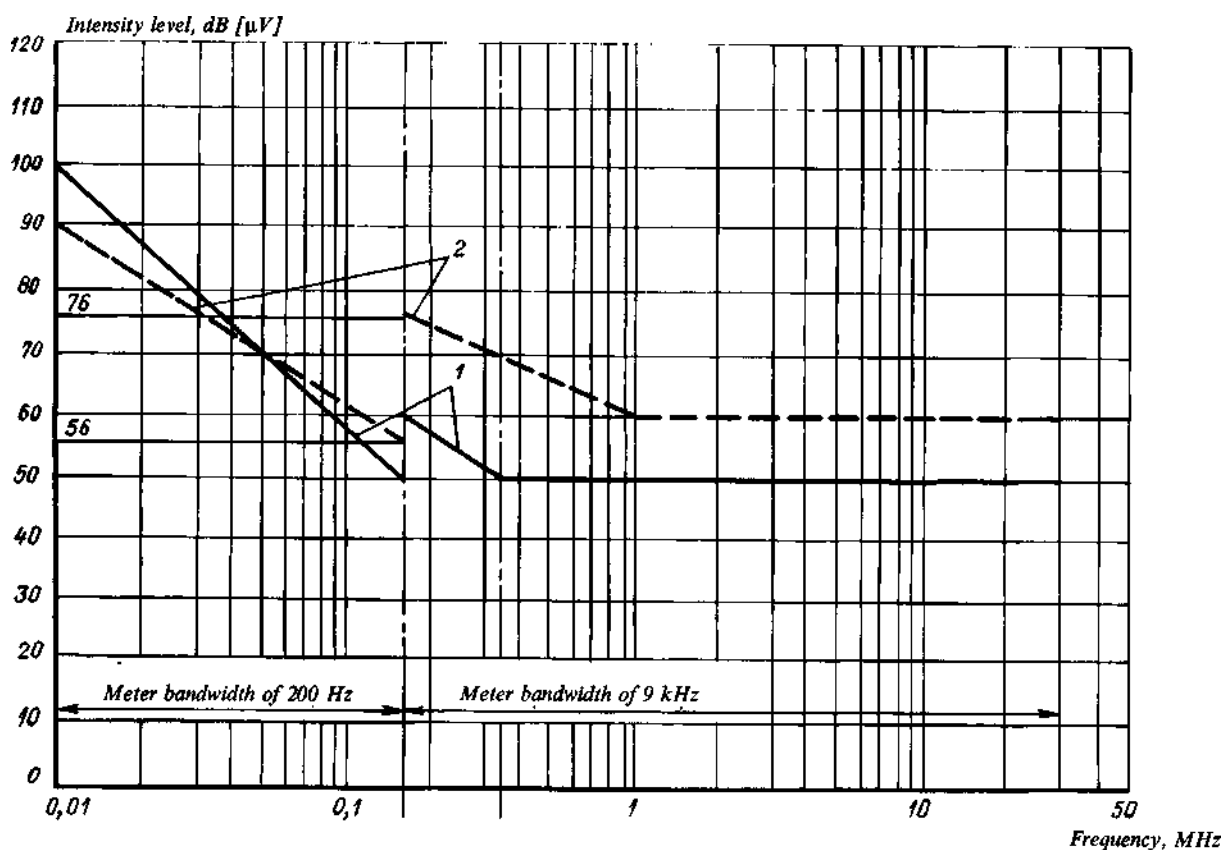

Fig. 2.2.1.4
Permissible levels of interference intensity

1 – from navigational and radio equipment as well as from electrical and automation equipment installed on the wheelhouse deck or above; 2 – from equipment installed below the wheelhouse deck

2.2.2 Measures to ensure electromagnetic compatibility.

2.2.2.1 To ensure protection of radio equipment against electromagnetic interference, the requirements of Part IV "Radio Equipment" of the Rules for the Equipment of Sea-Going Ships¹ shall be taken into account.

2.2.2.2 To protect an electrical network against interference, interference suppression devices and galvanic isolating devices shall be used: filters, reactors, isolating transformers, rotary converters.

2.2.2.3 Power cable screens, metal sheath or armour shall be connected to the metal casing of relevant equipment and shall be earthed as frequently as possible, at each cable end as a minimum.

2.2.2.4 The screens of information signal cables and of control circuit cables shall be generally earthed at one end only on the side of the initial signal processing block. In this case, the cable shall have an external insulating sheath.

2.2.2.5 Continuous screening shall be ensured, and for this purpose cable screens shall be connected to equipment casings, and it shall also be ensured in cable branch boxes and cable distribution boxes, and in way of cable penetrations through bulkheads.

2.2.2.6 The earthing of metal housings of electrical and electronic equipment shall have an electric resistance not greater than 0,02 Ohm, minimum length possible, shall be resistant to vibration and corrosion, and shall be readily accessible for inspection.

2.2.2.7 Cable screens shall not be used as return conductors.

¹ Hereinafter referred to as "the RS Rules/E"

2.2.2.8 All information signal cables shall be screened and laid at a distance of at least 20 cm away from unscreened power cables and control circuit cables. For parallel laying, the above distance shall be increased up to 50 cm. Cables crossing shall be made at a right angle.

2.2.2.9 It is recommended to lay analog signal cables away from digital signal cables. Parallel laying of cables, which carry digital and analog signals, in one cable run shall be avoided. Where separate cable laying is impossible, the cables, which conduct analog low level signals, shall be laid in steel pipes or metal conduits (troughs) provided with current-conducting connections between themselves and the unit's hull. The cables of electroacoustic system circuits and similar to them shall be laid in metal pipes and away from other cables.

2.2.2.10 The entire cable network laid in the spaces in which the equipment of communication and radio navigation means is installed, as well as on the upper decks and superstructures not separated from aials with a metal deck or bulkhead is made with screened cables observing screening continuity. When the supply cable of a radio equipment switchboard is led into a radio room, a radio interference filter shall be mounted at its entry.

2.2.2.11 The screens and housing of the electrical equipment in spaces with radio equipment shall be earthed. In accordance with [2.5.3.5](#), the screens of cables and wires shall be also earthed. The housing and screens of the electrical equipment may not be earthed provided it does not produce radio interference and not need protective earthing.

2.2.2.12 When electrical equipment is installed or cables are laid in the vicinity of magnetic compasses, as well as, to ensure protection against interference from other navigational equipment, the requirements of Part V "Navigational Equipment" of the RS Rules/E shall be taken into account.

2.3 MATERIALS

2.3.1 Structural materials.

2.3.1.1 The structural parts of electrical equipment shall be fabricated of durable materials, that do not contain asbestos, rated at least as having low flame-spread characteristics, resistant to sea air, oil and fuel vapour effects, or reliably protected against such effects.

2.3.1.2 Screws, nuts, hinges and similar items designed to fasten enclosures of the electrical equipment to be installed on weather decks or in spaces with increased humidity shall be made of corrosion-resistant materials or have effective corrosion-resistant covering.

2.3.1.3 All current-carrying parts of electrical equipment shall be made of copper, copper alloys or other materials of equivalent qualities with the exception of:

.1 rheostat elements which shall be made of mechanically durable materials having high resistivity and capable of withstanding high temperatures;

.2 short-circuit rotor windings of asynchronous motors which may be made of aluminium or its alloys resistant to sea conditions;

.3 carbon brushes, cermet contacts and other similar parts where the properties specified so require;

.4 parts of electrical equipment directly connected to the MODU hull used as a return wire in a local single-wire system.

2.3.2 Insulating materials.

2.3.2.1 Insulating materials of live parts shall not contain asbestos and shall have adequate dielectric strength and resistance to creepage currents, moisture and oil, as well as sufficient mechanical strength or shall be properly protected. The heating temperature of current-carrying parts and their connections shall not exceed the permissible heating temperature of the insulating materials at the rated load.

2.3.2.2 Non-combustible liquids with the relevant insulating and heat-conducting characteristics may be used for cooling uninsulated parts of electrical equipment.

2.3.2.3 The insulating materials used for winding insulation in machines, apparatus and other equipment for essential services shall comply with the national agreed standards. The use of insulating materials not inferior to Class E is recommended.

2.3.2.4 Conductors used in electrical devices for internal connections shall have insulation made of materials rated as having low flame-spread characteristics, and for apparatus with increased heating and also for those specified in [Section 15](#) – of non-combustible materials.

2.3.2.5 For insulating materials used for cable manufacture, refer to [16.3](#).

2.4 STRUCTURAL REQUIREMENTS AND DEGREE OF PROTECTION OF ELECTRICAL EQUIPMENT

2.4.1 General.

2.4.1.1 Such parts which require replacement while in service shall be easily dismountable.

2.4.1.2 Where screw fastenings are employed, provision shall be made to exclude self-loosening of screws and nuts or, where dismantling and opening are a frequent occurrence, loss of same.

2.4.1.3 Gaskets used in components of electrical equipment (such as doors, covers, sight holes, packing glands, etc.) shall ensure adequate protection when in service. The gaskets shall be secured to the covers or casings.

2.4.1.4 Casings, panels and covers of electrical equipment installed in places accessible to unspecialized personnel shall be opened with tools or special keys only.

2.4.1.5 Suitable water drainage arrangements shall be provided in electrical equipment where condensation is likely to occur. Channels shall be fitted inside the equipment to provide for all condensate drainage from all equipment components. The windings and live parts shall be so arranged or protected that they are not exposed to the effects of such condensate.

2.4.1.6 Electrical equipment with forced ventilation designed for installation in bottom parts of damp spaces shall be provided with such a ventilation system, so as to avoid the suction of moisture and oil vapours inside the equipment.

2.4.1.7 Where measuring instruments with oil, petroleum products, steam or water supply are fitted in a control panel or desk, measures shall be taken to prevent these agents from making contacts with the live parts in case of damage to the instruments or pipelines.

2.4.1.8 The portable standard electrical equipment for use in particularly damp locations and spaces shall be of the safety voltage type.

2.4.1.9 All electrical apparatus shall be so designed and installed that they cannot injure personnel in maintenance and if touched during normal operation.

2.4.2 Insulation clearances.

Clearances between live parts at different potentials, or between live parts and earthed metal parts or outer enclosure, both in air and across the insulating surface shall be in conformity with the operating voltage and operating conditions of the installation taking into account the properties of the insulating materials in use.

2.4.3 Internal wiring.

2.4.3.1 Stranded wires shall be used for internal wiring of electrical equipment throughout.

2.4.3.2 For internal wiring of switchgears, control desks and other distribution and switching arrangements, etc., wires of not less than 1 mm² in cross-sectional area shall be used. For systems of control, protection, measurement of different parameters, signalling and internal communication, the use of wires having a cross-sectional area not less than 0,5 mm² is permitted.

For electronic and electrical devices for transformation and transmission of low-power signals, wires not less than 0,2 mm² in cross-sectional area may be used.

2.4.3.3 Current-carrying parts shall be so attached that they shall not sustain any additional mechanical stresses; such parts shall not be attached by screws fitted directly into insulating materials.

2.4.3.4 Stranded cores, cables and wires shall have their ends fitted out to suit the type of terminal used, or shall be provided with lugs.

2.4.3.5 Insulated wires shall be laid up and secured in such a manner that insulation resistance shall not be reduced, and they shall not be exposed to damages due to electrodynamic loads, vibration and shocks.

2.4.3.6 Arrangements shall be made to ensure that the temperatures allowed for an insulated wire under normal service conditions or for the duration of short-circuit current breaking are not exceeded.

2.4.3.7 Insulated wires shall be so connected to terminals or busbars that the wire insulation shall not be exposed to the overheating temperature under all operating conditions.

2.4.4 Degree of protection of electrical equipment enclosures.

2.4.4.1 Depending on location, the use shall be made of electrical equipment in appropriate protective enclosure, or other suitable measures shall be taken to protect equipment from harmful effect of the environment and to protect the personnel from electric shock hazards.

2.4.4.2 The minimum degree of protection of electrical equipment installed in MODU spaces and areas shall be chosen from [Table 2.4.4.2](#).

Table 2.4.4.2

Spaces in which electrical equipment is installed	Electrical equipment				
	Electrical machines, transformers	Switchboards, control gear, starters, control panels	Communication and signalling automation equipment, accessories (switches, sockets, junction boxes)	Space heating and cooking appliances	Lighting fixtures
Spaces and areas in which explosive mixtures of vapours, gases and dust with air are likely to occur	Ex (refer to 2.11)		Ex (refer to 2.11)		Ex (refer to 2.11)
Dry spaces, dry accommodation, special electrical rooms	IP20	IP20	IP20	IP20	IP20
Navigating bridge, radio room	IP22	IP22	IP22	IP22	IP22
Service spaces, steering gear compartments, refrigerating plant rooms (except for ammonia equipment), emergency diesel generator room, general purpose stores. Pantries, provision stores	IP22	IP22	IP22	IP22	IP22
Engine and boiler rooms:					
above plating	IP22	IP22	IP22	IP22	IP22
below plating	IP44	–	IP44	IP44	IP44
control stations (dry)	IP22	IP22	IP22	IP22	IP22
enclosed separator rooms	IP44	IP44	IP44	IP44	IP44
Refrigerated spaces, galleys, laundries, bathrooms, showers	IP44	IP44	IP55	IP44	IP 44
Process spaces, shafting tunnels, cargo holds	IP55	IP55	IP55	IP55	IP 55
Open decks	IP56	IP56	IP56	IP56	IP 56
Note. Where the equipment enclosure does not guarantee the necessary protection, alternative methods of protection or alternative arrangement of equipment shall be applied to ensure the required degree of protection.					

2.4.4.3 Where liquid ingress onto electric panels of control and alarm systems or onto the like electrical equipment, which is necessary to ensure the safety of the unit, is likely to occur, such equipment shall have the enclosure protection at least IP23.

2.4.4.4 Additional requirements for the protection of electrical equipment with voltage above 1000 V are specified in [Section 18](#).

2.5 PROTECTIVE EARTHING OF METAL PARTS OF ELECTRICAL EQUIPMENT WHICH DO NOT CARRY CURRENT

Metal enclosures of electrical equipment operated at a voltage exceeding the safety level and having no double or reinforced insulation shall be fitted with an earth terminal marked with a standard symbol.

Provision shall be made for earthing inside and outside of the electrical equipment enclosure dependent on its purpose.

Additional requirements for the earthing of equipment with voltage above 1000 V are specified in [Section 18](#).

2.5.1 Parts to be earthed.

2.5.1.1 Metal parts of electrical equipment housings (enclosures), which are likely to be touched under service conditions and which may become live in the event of insulation damage (except for those mentioned in [2.5.1.2](#)) shall have a reliable electric contact with the MODU hull part fitted with an earth terminal (refer to [2.5.3](#)).

2.5.1.2 Protective earthing is not required for:

- .1 electrical equipment supplied with current at a safety voltage;
- .2 electrical equipment provided with double or reinforced insulation;
- .3 metal parts of electrical equipment fastened in insulating material or passing therethrough and separated from earthed and live parts in such a way that these parts cannot become live or come in contact with earthed parts under normal operating conditions;
- .4 bearing housings isolated to guard against circulating currents;
- .5 lamp caps and fasteners for luminescent lamps, lamp shades, reflectors and guards supported on lamp holders or lighting fixtures constructed of, or shrouded in insulating material;
- .6 cable clips, cleats, etc.;
- .7 individual consumer – under voltage up to 250 V supplied through an isolating transformer.

2.5.1.3 The shields and metal armour of cables shall be earthed.

2.5.1.4 The secondary windings of all instrument transformers for current and voltage shall be earthed.

2.5.2 Earthing of structures on steel MODU.

2.5.2.1 Superstructures of aluminium alloys fastened to the steel hull but insulated therefrom, shall be earthed by at least two special wires, each having a cross-sectional area of at least 16 mm², which will not start electrolytic corrosion at the points of their connections with the superstructure and hull. Such earthing connections shall be provided at different locations around the superstructure perimeter, shall be accessible for inspection and protected from damages.

2.5.2.2 All stationary installed mechanical equipment, piping, metal structures of derricks, masts and helidecks shall be reliably earthed if special conditions for mounting the above equipment or structures on board the MODU are not specified.

2.5.3 Earth terminals and conductors.

2.5.3.1 Earth conductors with a cross-sectional area above 4 mm² and up to 4 mm² shall be connected to the hull with bolts at least 6 mm and bolts 5 mm in diameter, respectively. For earth conductors with a cross-sectional area up to 2,5 mm², bolts 4 mm in diameter may be used. The bolts shall not be used for purposes other than earth conductors connection. The bolts screwed into the hull material without nuts shall be made of brass or other corrosion-resistant material. The hull in places of earthing conductor connection shall be cleaned to metal and properly protected against corrosion.

2.5.3.2 Fixed electrical equipment shall be earthed by means of external earthing conductors or an earthing core in the feeding cable. When earthing is effected with a special core of the feeding cable, it shall be connected to the earthing device inside the enclosure of the electrical equipment.

Such earthing effected with external earthing conductors need not be provided in case the arrangement of equipment ensures a reliable electrical contact between the equipment enclosure and the MODU metal hull under all operating conditions.

For earthing effected with an external earthing conductors, the use shall be made of copper conductors, as well as conductors of any other corrosion-resistant metal provided the resistance of these conductors does not exceed that of the required copper conductor. The cross-sectional area of copper earthing conductor shall not be less than that specified in [Table 2.5.3.2](#).

Table 2.5.3.2

Cross-sectional area of feeding cable core, mm ²	Cross-sectional area of earthing conductor of fixed electrical equipment, mm ² , min	
	solid	stranded
Up to 2,5	2,5	2,5
2,5 to 120	Half the cross-sectional area of feeding cable core, but not less than 4	
Over 120	70	

In case of earthing is effected with the special core of the feeding cable, the cross-sectional area of this core shall be equal to the nominal cross-sectional area of the feeding cable core for cables having a cross-sectional area up to 16 mm², and at least half the cross-sectional area of the feeding cable core, but not less than 16 mm², for cables having a cross-sectional area over 16 mm². At that, earthing resistance shall not exceed 0,4 Ohm.

2.5.3.3 Earthing of movable, loose and portable consumers shall be effected through and earthed jack in the socket outlet or other earthed contact device and a copper earthing core of the feeding flexible cable. The cross-sectional area of the earthing core shall not be less than the nominal cross-sectional area of the feeding flexible cable core for cables up to 16 mm² and at least half the cross-sectional area of the feeding flexible cable core, but not less than 16 mm², for cables over 16 mm².

2.5.3.4 Earthing of the fixed equipment shall be non-disconnectable.

2.5.3.5 Earthing of shields and metal armour of cables shall be effected in one of the following ways:

.1 using a copper earth wire of a cross-section not less than 1,5 mm² for cable conductors with a cross-sectional area up to 25 mm² and not less than 4 mm² for cable conductors with a cross-sectional area over 25 mm²;

.2 by adequate attachment of the shields and metal armour to the MODU hull;

.3 by means of cable gland rings provided these are characterized by corrosion resistance, good conductivity.

2.5.3.6 External earthing conductors shall be accessible for inspection and protected against corrosion and mechanical damages.

2.6 LIGHTNING PROTECTION

2.6.1 General.

2.6.1.1 In MODU provision shall be made for lightning protection devices covering the zone to be protected.

In MODU, where consequential effects of lightning strokes may cause a fire or explosion, lightning protection earthing devices shall also be fitted to preclude consequential sparking.

2.6.1.2 Lightning protection device shall consist of an air terminal, down conductor and earth termination. On metal masts no special lightning protection device need be fitted if provision is made for reliable electrical connection of the mast to the MODU metal hull or earthing point.

2.6.1.3 Legs of arrangements for lifting and lowering columns of self-elevating MODU during towing operation, as well as after positioning, shall be earthed by bonding. This bonding shall be in compliance with the requirements of [2.6.3.1](#) and [2.6.3.2](#).

2.6.2 Air terminals.

2.6.2.1 In MODU the vertical structures (derricks, masts, derrick posts, superstructures, etc.) shall be used as air terminals if provision is made for reliable electrical connection of these structures to the metal hull.

Additional air terminals shall be used only when proper structural elements do not provide for reliable lightning protection.

2.6.2.2 If electrical equipment is installed on the top of the metal mast, provision shall be made for an air terminal, which is effectively earthed.

2.6.2.3 The air terminal shall be made of a rod at least 12 mm in diameter. The rod may be of copper, copper alloys or steel protected against corrosion. For aluminium masts an aluminium rod shall be used.

2.6.2.4 The air terminal shall be fitted to the mast in such a manner that it projects at least 300 mm above the top of the mast or above any device fitted on its top.

2.6.3 Down conductor.

2.6.3.1 The down conductor shall be made of a rod, strip or multiwire cable having a cross-sectional area not less than 70 mm² for copper or its alloys, and not less than 100 mm² for steel. Steel down conductors shall be protected against corrosion.

2.6.3.2 Down conductors shall run on the outer side of masts and superstructures with a minimum number of bends, which shall be fair and have as large radius as practicable.

2.6.3.3 Down conductors shall not run through hazardous spaces and zones.

2.6.4 Earth termination.

On MODU, any metal structures immersed in water under all operational conditions or having reliable electrical contact with sea water or seabed may be used as an earth termination.

2.6.5 Connections in lightning protective device.

2.6.5.1 Connections between the air terminal, down conductor and earth termination shall be welded or bolted with clamps.

2.6.5.2 The contacting surface area between the down conductor, air terminal and earth termination shall be not less than 1000 mm².

The connecting clamps and bolts shall be made of copper, its alloys or steel protected against corrosion.

2.6.6 Lightning protection earthing devices.

2.6.6.1 Lightning protection earthing shall be provided for isolated metal structures, flexible connections, pipelines, screens of power and communication lines, and entry assemblies of hazardous spaces.

2.6.6.2 Petroleum product pipelines, and also all other piping associated with hazardous spaces and located on exposed parts of the deck or in spaces which are free from electromagnetic screening, shall be earthed to the hull not less than every 10 m lengthwise.

The pipelines not associated with hazardous spaces and located on the deck where explosive gases are likely to appear, shall be earthed to the hull not less than every 30 m lengthwise.

2.6.6.3 Metal parts near to down conductors shall be earthed if they are not fixed to earthed structures or have no other metal connection to the MODU hull. Arrangements or metal parts located at a distance up to 200 mm from the down conductors shall be so connected to the down conductor that consequential sparking is excluded.

2.6.6.4 All joints of earthing elements shall be accessible for inspection and protected against mechanical damages.

2.7 ARRANGEMENT OF ELECTRICAL EQUIPMENT

2.7.1 Electric equipment shall be installed in such a manner as to provide convenient access to controls and to all parts that require maintenance, inspection and replacement.

2.7.2 Electrical machines shall, where possible, be installed so that MODU rolling effect along all axes is kept to a minimum. The design of electrical machine bearings and their lubrication system shall sustain the above rolling effects under storm conditions without disturbances and loss of lubricating oil, and to remain operational during the prolonged periods of time at the heel and trim specified in [2.1.2.2](#).

2.7.3 Essential electrical equipment on board each MODU, e.g. generators, main and other switchboards, electric motors and their starting apparatus shall be arranged and protected so that they remain operational in the event of emergency partial flooding of the machinery space with bilge water above the level of the upper boundary of tanks. The design limit of "partial flooding" shall be within the depth of water in a space equal to 1,5 m.

2.7.4 Electrical equipment shall be arranged in relation to a magnetic compass so that a magnetic effect during its switching-in or switching-off does not cause the compass deviation of more than 30"(0,05°).

2.7.5 Air-cooled electrical equipment shall be located so that cooling air is not taken from bilges or other spaces wherein the air may be contaminated with vapours or dust of substances having a harmful effect on insulation.

2.7.6 The electrical equipment placed in locations subject to vibrations and shocks (heavier than those specified in [2.1.2.1](#)) which are impossible to eliminate, shall be so designed as to ensure its normal operation under these conditions or to be mounted on relevant shock-absorbers.

2.7.7 Electrical equipment shall be fixed so that the strength of decks, bulkheads and hull plating is not reduced and their tightness is not impaired.

2.7.8 Open live parts of electrical equipment shall not be located closer than 300 mm horizontally and 1200 mm vertically to non-protected combustible materials.

2.7.9 Where the enclosures of electrical equipment are made of different material than the structures on which they are installed, care shall be taken, if necessary, to prevent electrolytic corrosion.

2.8 SPECIAL ELECTRICAL ROOMS

2.8.1 The doors of special electrical rooms shall be locked. These doors shall open on the outside. In case the doors face corridors and passageways in accommodation and service spaces, it is permitted that these doors open on the inside on condition that protection guards and stops are provided. A warning notice shall be placed on the door. From the inside of the space the door shall open without a key.

2.8.2 Special electrical rooms shall not be adjacent to the compartments and tanks filled with flammable liquids. If this requirement is not feasible from the structural point of view, measures shall be taken eliminating the possibility of flammable liquid penetration into these spaces.

2.8.3 No exits, side scuttles of the opening type or other openings are permissible from special electrical rooms into dangerous spaces.

2.8.4 Handrails of isolating material shall be installed in special electrical rooms, in passageways and servicing areas when the open-type electrical equipment is used.

2.9 HAZARDOUS AREAS

2.9.1 Areas and spaces on board the MODU shall be classified into hazardous and non-hazardous in accordance with the requirements of [2.9.2 — 2.9.5](#).

Hazardous zones are enclosed spaces, semi-enclosed and outdoor locations in which, due to presence of flammable gas/air mixture, explosion hazard exists continuously or periodically.

For the purpose of machinery and electrical installations, hazardous areas are classified as in [2.9.3 — 2.9.5](#). Hazardous areas not covered (such as, but not limited to, well test equipment areas, helicopter fuel storage areas, acetylene cylinder storage areas, battery rooms, paint lockers, flammable gas or vapour vents and diverter line outlets) in [2.9.3 — 2.9.5](#) shall be classified as in [2.9.2](#).

2.9.2 Hazardous areas are subdivided into zones as follows:

Zone 0 is an area in which ignitable concentrations of flammable gases or vapours are continuously present or present for long periods;

Zone 1 is an area in which ignitable concentrations of flammable gases or vapours are likely to occur in normal operation;

Zone 2 is an area in which ignitable concentrations of flammable gases or vapours are not likely to occur, or in which such a mixture, if it does occur, will only exist for a short time.

2.9.3 Zone 0 covers:

.1 the internal spaces of closed tanks and piping for containing active non-degassed drilling mud, oil that has a flashpoint below 60 °C or flammable gas and vapour, as well as produced oil and gas in which an oil/gas/air mixture is continuously present or present for long periods;

.2 internal spaces of open type process equipment from the surface of drilling mud to upper openings;

.3 internal spaces of escape gas outlet pipes discharging oil/gas/air mixture from spaces specified in this paragraph.

2.9.4 Zone 1 covers:

.1 enclosed spaces containing any part of the mud-circulating system that has an opening into the spaces and is between the well and the final degassing discharge which contain detachable joints, manholes or other elements being a possible source of release of oil/gas/air mixture;

.2 enclosed spaces or semi-enclosed locations that are below the drill floor and contain a possible source of release of oil/gas/air mixture, such as the top of a drilling nipple;

.3 outdoor locations below the drill floor and within a radius of 1,5 m from a possible source of release of oil/gas/air mixture such as the top of a drilling nipple;

.4 enclosed spaces that are on the drill floor and which are not separated by a solid floor from the spaces in [2.9.4.2](#);

.5 in outdoor or semi-enclosed locations, except as provided for in [2.9.4.2](#), the area within 1,5 m from the boundaries of any openings to equipment which is part of the mud system as specified in [2.9.4.1](#), as well as the area within 1,5 m from any ventilation outlets of Zone 1 spaces, or any access to Zone 1 spaces;

.6 pits, ducts or similar structures in locations which would otherwise be Zone 2 but which are so arranged that dispersion of gas may not occur.

2.9.5 Zone 2 covers:

.1 enclosed spaces which contain open sections of the mud circulating system from the final degassing discharge to the mud pump suction connection at the mud pit (degassed drilling mud);

.2 outdoor locations within the boundaries of the drilling derrick up to a height of 3 m above the drill floor;

.3 semi-enclosed locations below and contiguous to the drill floor and to the boundaries of the derrick or to the extent of any enclosure (bulkhead) which is liable to trap gases;

.4 in outdoor locations below the drill floor, within a radius of 1,5 m area beyond the Zone 1 area as specified in [2.9.4.3](#);

.5 the areas 1,5 m beyond the Zone 1 areas specified in [2.9.4.5](#) and beyond the semi-enclosed locations specified in [2.9.4.2](#);

.6 outdoor areas within 1,5 m of the boundaries of any ventilation outlet from or access to Zone 2 space (from a non-hazardous area);

.7 semi-enclosed derricks to the extent of their enclosure above the drill floor or to a height of 3 m above the drill floor, whichever is greater;

.8 air-closed spaces (locks) between Zone 1 and non-hazardous areas.

2.9.6 Other locations and spaces not associated with Zones 0, 1 and 2 relate to non-hazardous locations and spaces.

2.9.7 Hazardous zones classification for locations and spaces in accordance with [2.9.3—2.9.5](#) may, in each particular case, be changed at the Register request depending on the structural features of the unit and the conditions of locations and spaces ventilation.

2.10 OPENINGS, ACCESS AND VENTILATION CONDITIONS AFFECTING THE EXTENT OF HAZARDOUS ZONES

2.10.1 Except for operational reasons access doors or other openings should not be provided between:

- non-hazardous and hazardous zone,
- a Zone 2 space and a Zone 1 space.

2.10.2 Where access doors or other openings are provided between spaces specified in the previous paragraph, the explosion hazard of any space with such openings is determined as follows:

.1 a non-hazardous space becomes hazardous of the same zone from where an access through doors or other openings is available;

.2 a hazardous space of Zone 2 becomes a hazardous space of Zone 1 except for cases specified in [2.10.3](#).

2.10.3 An enclosed space with direct access to any Zone 1 location can be considered as Zone 2 if:

.1 the access is fitted with a gas-tight door opening into the Zone 2 space;

.2 ventilation is such that the air flow with the door open is from the Zone 2 space into the Zone 1 location;

.3 loss of ventilation is alarmed at a manned station.

2.10.4 An enclosed space with direct access to any Zone 1 location is not considered hazardous if:

.1 the access is fitted with gas-tight self-closing doors forming an air lock;

.2 the space has ventilation overpressure in relation to the hazardous location (space) of Zone 1;

.3 loss of ventilation overpressure is alarmed at a manned station.

2.10.5 An enclosed space with direct access to Zone 2 location is not considered hazardous if:

.1 the access is fitted with a self-closing gas-tight door that opens into the non-hazardous location;

.2 ventilation is such that the air flow with the door open is from the non-hazardous space into the Zone 2 location;

.3 loss of ventilation is alarmed at a manned station.

2.10.6 Where a ventilation system, which ensures explosion proofness of a space, meets the requirements of the MODU Rules to prevent any ingress of gases from Zone 1 location, the two self-closing doors forming an air lock may be replaced by a single self-closing gas-tight door that opens into the non-hazardous location.

2.10.7 No hold-back devices are permitted for self-closing doors.

2.10.8 All self-closing gas-tight doors shall have caution notes to the effect that the doors shall be closed at all times.

2.10.9 Piping systems shall be designed to preclude direct communication between hazardous zones of different classifications, and also between hazardous and non-hazardous zones. Where passing through hazardous areas, the inlet ducts shall have overpressure in relation to this area; where the ventilation duct passes through a hazardous area of a lower level, the ventilation duct shall have under pressure in relation to this area.

2.11 ELECTRICAL EQUIPMENT AND CABLES IN HAZARDOUS AREAS

2.11.1 The requirements of this Chapter refer to the equipment installed in hazardous enclosed spaces and semi-enclosed locations relating to hazardous Zones 0, 1 and 2.

These spaces include storerooms for volatile flammable substances, battery rooms and spaces containing tanks, machinery and piping for flammable liquids with a vapour flashpoint 60 °C and less.

2.11.2 Electrical equipment installed in hazardous zones shall be certified as to its hazard irrespective whether the above equipment is subject to the Register technical supervision according to the requirements of [1.3.3.1](#).

Certification determining the explosion protection type of the electrical equipment shall be carried out by competent independent bodies, the documents (certificates) of which are recognized by the Register.

2.11.3 In hazardous spaces and areas, it is permitted to install only explosion-proof electrical equipment of the explosion protection type that is consistent with the category and group of the most hazardous gas mixture which may be present at the place of installation.

2.11.4 In spaces of hazardous Zone 0, certified electrical equipment and cables only of the explosion protection type "intrinsically safe electric circuit" (*Exia*) may be installed.

2.11.5 In locations and spaces of Zone 1, certified electrical equipment of the following explosion protection types may be installed:

- .1 "intrinsically safe electric circuit" (*Exia*, *Exib*)
- .2 "flameproof enclosure" (*Exd*);
- .3 "increased safety" (*Exe*);
- .4 "special protection type" (*Exs*);
- .5 "pressurized enclosure" (*Exp*).

2.11.6 In locations and spaces of Zone 2, certified electrical equipment of the following types may be installed:

- .1 listed in [2.11.5](#);
- .2 special design of protection type (*Exn*);
- .3 non-explosion-proof equipment with the IP55 and higher type enclosure, which ensures absence of sparks and arcs in standard operating conditions, and the maximum surface temperature of which shall not reach the ignition point of any gas/vapor which may be present in the explosion hazardous areas.

2.11.7 Electrical equipment except for GMDSS antennas and their matching systems, installed in hazardous Zone 2 and also outside hazardous zones but intended for operation in emergency (e.g., in cases of uncontrolled well blow-out resulting in extension of hazardous zones) shall be of explosion-proof type required for Zone 1.

2.11.8 Explosion-proof lighting fixtures shall be installed so that clear space, except for the place of fastening, of at least 100 mm wide remains around them.

2.11.9 Fastening of electrical equipment immediately to surfaces of combustible liquid tanks is not permitted. In any case, the electrical equipment shall be fastened at a distance of at least 75 mm from the tank surfaces.

2.11.10 In hazardous zones, the cables of the following types may be laid:

- .1 in hazardous Zone 0: cable types specially intended for implementation of "intrinsically safe electric circuit";
- .2 in hazardous Zone 1, all cables shall have: a non-metallic impervious outer sheath over a screening or protective metallic braid; or
a non-metallic impervious outer sheath and the copper one (for mineral-insulated cables);
- .3 in hazardous Zone 2, all cables shall have: sheaths as specified for Zone 1; a non-metallic outer sheath without a metallic screening or protective braid provided relevant protection against mechanical damages is ensured.

2.11.11 In hazardous locations and spaces, cables intended only for the electrical equipment installed in those locations and spaces may be laid. Through cables via the above locations and spaces may be laid provided the requirements of [2.11.10](#) are met.

2.11.12 All shields, and also metallic braids of cables of supply circuits for electric motors and lighting circuits, which pass through hazardous locations and spaces or supply electrical equipment installed in these, shall be earthed at least at both ends.

2.11.13 Intrinsically safe circuit cables may be used for one device only and shall be laid separately from other cables.

Cables of portable electrical devices, except for intrinsically safe circuit cables, shall not pass through hazardous locations and spaces.

In paint lockers and ventilation ducts serving these spaces it is permitted to install only that electrical equipment which is necessary for serving the given space. This electrical equipment shall be explosion-proof of the type:

- .1 intrinsically safe electric circuit (*Exi*);
- .2 with pressurized enclosure (*Exp*);
- .3 with flameproof enclosure (*Exd*);
- .4 increased safety (*Exe*);
- .5 special protection type (*Exs*).

2.11.14 The minimum requirements for electrical equipment by the explosion protection type shall be consistent with the gas mixture category IIB and gas mixture group T3.

2.11.15 Enclosed spaces giving access to paint lockers may be considered as non-hazardous provided that:

- .1 the door into the paint locker is gas-tight, self-closing and has no hold-back device;
- .2 the paint lockers are provided with an independent exhaust ventilation system and/or with a supply ventilation system having air intake from places located outside hazardous areas; ventilation system switching-off is alarmed at a manned station;
- .3 caution-notes are fitted at the entrance stating that the locker contains flammable liquids.

2.12 ANTISTATIC EARTHING

2.12.1 Antistatic earthing is a mandatory means of ensuring electrostatic intrinsic safety for all types of MODU having hazardous spaces and zones.

2.12.2 Stationary and portable equipment installed in enclosed and semi-enclosed spaces and zones, where explosive mixtures of vapors, gases or dust with air are likely to occur, shall be antistatically earthed.

2.12.3 At all entrances to hazardous spaces and zones conditions shall be provided to remove electrostatic charge from people entering those spaces and zones through installation of metal earthed plates, handrails or handles to remove charge when touched with the hand or by placing wet mats (rugs) at entry.

2.12.4 The following equipment does not require use of antistatic earthing conductors:

- .1 electrical equipment (including portable one) earthed in accordance with [2.5](#);
- .2 pipes and conduits for installation of cables earthed in accordance with [16.8.8](#);
- .3 electrical equipment, automation equipment, radio equipment and navigational equipment earthed in accordance with [2.2.2](#);
- .4 equipment and structures provided with lightning protection earthing in accordance with [2.6.6](#).

2.12.5 Arrangement and monitoring of antistatic earthing.

2.12.5.1 Unless otherwise specified, the design of the antistatic earthing conductors shall comply with the requirements of [2.5](#). The method of connecting antistatic earthing conductors to non-metal equipment such as plastic piping shall be specified by the equipment manufacturer.

2.12.5.2 Design of the antistatic earthing conductors shall meet the requirements of this Chapter and standards approved by the Register.

2.12.5.3 The resistance value measured between the equipment (component, structure) being monitored and MODU hull shall not exceed 10^6 Ohm with the area of contact between the measure electrode and the equipment surface being no more than 20 mm². Resistance of the antistatic earthing shall be monitored by a measuring device (ohmmeter) with control d.c. voltage of not more than 10 V.

2.13 ARRANGEMENTS AND SYSTEMS FOR INSULATION RESISTANCE MONITORING

2.13.1 In each isolated ship power system with the nominal voltage above 50 V AC or above 110 V DC provision shall be made for an automatic continuous monitoring of insulation resistance of current-carrying components relative to ship's hull. Measurements periodicity during the periodic monitoring shall not exceed 300 s.

2.13.2 In the networks with the voltage 1000 V and above monitoring of the insulation resistance shall be carried out only alive with the use of passive monitoring methods (for example, with the use of zero-sequence current transformer).

2.13.3 Devices for insulation resistance monitoring in the networks with the voltage up to 1000 V shall:

- be fitted with an indicator showing the insulation resistance value;
- have visible and audible alarm at decrease of controlled value under the prescribed limit;
- allow to perform smooth adjustment of alarm actuating setting value within the range from 100 to 5 kOhm. The current setting value shall be indicated;
- have an operation speed sufficient for measuring insulation resistance value in the networks with the existing capacity level during the measurement cycle of the device which shall not exceed 30 s;
- produce measuring current not exceeding 0,03 A under all modes (including transient);
- provide for the possibility of periodic intactness monitoring under operational conditions by means of earth leakage current through an active resistance equal to 80 % of resistance of the relevant setting actuating.

2.13.4 Location of devices for insulation resistance monitoring shall meet the requirements of [4.5.4.6](#).

3 MAIN SOURCE OF ELECTRICAL POWER

3.1 COMPOSITION AND CAPACITY OF MAIN SOURCE OF ELECTRICAL POWER

3.1.1 Every MODU shall be provided with a main source of electrical power whose capacity is sufficient to supply all MODU necessary electrical equipment under conditions specified in [3.1.4](#). Such a source shall consist of at least two independently-driven generators.

3.1.2 The number and capacity of independently-driven generators, and also of transformers and electric converters of which the main source of electrical power is composed, shall be such that if any of them failed, the rest would ensure:

.1 supply of the necessary electrical equipment under conditions specified in [3.1.4](#) with minimum comfortable habitable conditions on board the MODU guaranteed;

.2 start of the most powerful electric motor with the greatest starting current. In this case, the motor start shall not involve a voltage and frequency drop in the mains that could result in a fall out of synchronism, stop of generator prime mover or disconnection of machinery and apparatus being in operation;

.3 supply of process equipment, if cut, it may result in accident situations on board the MODU and in hazard for personnel;

.4 supply of an electric propulsion plant and/or generator sets of the MODU dynamic positioning system. For this purpose, an emergency source of electrical power may be used if its capacity proper or in association with the capacity of any other electrical power source ensures the simultaneous supply of emergency consumers specified in [9.3](#).

3.1.3 Given the proper redundancy and layout of electrical power supply units on board the MODU which prevent their simultaneous failure, and also their adequate capacity, it is permitted to use a common electric power plant for supply of essential consumers specified in [1.3.2](#), an electric propulsion plant, a dynamic positioning system and process equipment.

3.1.4 The number and capacity of electrical power supply units shall be determined with regard to the following modes of MODU operation:

.1 transit conditions and/or maneuvering;

.2 drilling of borehole;

.3 emergency operations, e.g. fire, flooding or others affecting MODU safety emergency conditions;

.4 other modes appropriate for the MODU design and purpose.

3.1.5 Supply of process equipment may be effected from the separate source of electrical power.

3.2 GENERATOR SETS

3.2.1 General.

3.2.1.1 Prime movers of generators shall meet the requirements of Section 3, Part VII "Machinery Installations and Machinery" of the MODU Rules and the additional requirements of this Chapter.

3.2.1.2 At short circuits in a network, the generators shall ensure the value of a steady short-circuit current sufficient for the actuation of protective devices.

3.2.1.3 Voltage and frequency regulation for independently-driven generators shall be ensured within the ranges specified respectively in [10.6](#) and [10.7](#), and in Section 3, Part VII "Machinery Installations and Machinery" of the MODU Rules.

3.2.1.4 The deviation from sine voltage for alternators shall not be over 5 % of the first-harmonic peak value.

3.2.2 Load sharing between sets running in parallel.

3.2.2.1 Alternating-current generator sets intended to run in parallel shall be provided with such a reactive-voltage drop compensating system that when the sets run in parallel, the reactive load sharing between the generators does not differ from a value proportional to their output by more than 10 % of the rated reactive load of the largest generator involved or by not more than 25 % of the rated output of the smallest generator if this value is lower than the above one.

3.2.2.2 When the alternating-current sets run in parallel at 20 to 100 % of the total load, generator currents may deviate within ± 15 % from the rated current value of the largest generator.

3.3 NUMBER AND CAPACITY OF TRANSFORMERS

3.3.1 On MODU where lighting and other essential services are powered through transformers, at least two transformers shall be provided of such a capacity that if the largest one fails, the others can satisfy the total demand for electrical power under all operating conditions of the MODU.

Where subdivided system of busbars is used, transformers shall be connected to different sections of the main switchboard.

3.4 POWER SUPPLY FROM EXTERNAL SOURCE OF ELECTRICAL POWER

3.4.1 If provision is made for MODU mains to be supplied from an external source of electrical power, an external supply switchboard shall be provided (refer also to [4.5.4.5](#)).

3.4.2 At the external supply switchboard, the following facilities shall be provided;

- .1** terminals for flexible cable connections;
- .2** switching and protective devices for connecting and protection of the permanently laid cable run to the main switchboard; where the cable length between the external supply switchboard and the main switchboard is less than 10 m, no protective devices may be fitted;
- .3** switched voltmeter or pilot lamps to indicate the presence of voltage from an external source of power across the terminals;
- .4** device or facilities for connecting a portable device to control polarity or phase sequence;
- .5** plate indicating voltage, the type of current and frequency;
- .6** arrangement for mechanical fastening of the end of a flexible cable connected to the switchboard and of a hanger for a cable, which are both to be arranged on the external supply switchboard or near it.

3.5 CONNECTION OF ELECTRICAL POWER SUPPLY UNITS

3.5.1 The electrical power supply units shall be adapted for long operation in parallel to feed common busbars. In this case, the connection circuit used shall ensure their switching-on for parallel operation for the duration of load transfer from one unit to another.

3.5.2 Where provisions are made for an automatic synchronization system, the necessary instruments and means to ensure standby manual synchronization shall be provided on the main switchboard.

3.5.3 Where required for initial excitation, a magnetizing device shall be fitted in the main switchboard for synchronous alternating-current generators.

3.5.4 Where its own electrical power supply units and external sources of electrical power are not intended to operate in parallel to the common busbars of the electrical installation, the system of connections, in this case, shall be so interlocked as to prevent their possible switching-on for parallel operation.

3.5.5 Disconnecting devices for disconnection of a collecting busbars system shall be fitted on the main switchboards intended for distribution of electrical power of generators operating in parallel. Consumers and generators, where possible, shall be symmetrically distributed among all collecting busbar systems.

Main switchboard busbars disconnecting devices may be:
circuit breaker without tripping mechanism, or
disconnecting link or switch by which busbars can be connected or disconnected easily and quickly.

Bolted links, for example bolted busbar sections, are not acceptable.

3.5.6 Under normal operational conditions, provision shall be made, as a rule, for supply of an emergency switchboard, i.e. of an emergency supply system for the MODU essential consumers, from the main switchboard.

3.6 UNINTERRUPTIBLE POWER SUPPLY

3.6.1 Uninterruptible power supplies (UPS), in addition to the below requirements, shall comply with IEC 62040-3:2011 standard and applicable requirements of national standards.

3.6.2 UPS shall be manufactured in compliance with the applicable requirements of IEC 62040-1:2017, IEC 62040-2:2016, IEC 62040-3:2011, IEC 62040-4:2013 and/or IEC 62040-5-3016 standards.

3.6.3 UPS complying with these requirements may be used as emergency or transitional sources of power required by [Section 9](#).

3.6.4 The type of UPS shall be appropriate to power supply requirements of the connected load equipment.

3.6.5 UPS shall be provided with a bypass ensuring power supply to connected load from the ship's mains if the inverter fails.

3.6.6 Each UPS shall be provided with audible and visual alarm to be given in normally attended location for:

- power supply failure to the connected load;
- earth fault;
- operation of accumulator battery protective device;
- accumulator battery is being discharged;
- bypass operation for permanent on-line UPS.

3.6.7 Requirements for UPS arrangement shall be similar to the requirements for arrangement of the emergency or transitional source of electrical power.

3.6.8 UPS with sealed-in accumulator batteries may be arranged at any spaces except for accommodation spaces, where sufficient ventilation is provided in compliance with the applicable requirements of IEC 62040-1:2018 and IEC 62040-3:2011 standards.

3.6.9 UPS shall maintain rated voltage and frequency on the load side throughout the whole time necessary to supply the connected consumers.

3.6.10 On restoration of the voltage in the supply circuit, the USP rectifier capacity shall be sufficient to maintain rated voltage and frequency on the load side with simultaneous recharging the battery by maximum possible charging current.

3.6.11 The accelerated charging of the UPS accumulator batteries by the maximum possible charging current shall be interlocked with the ventilation of the space where the UPS batteries are installed.

4 DISTRIBUTION OF ELECTRICAL POWER

4.1 DISTRIBUTION SYSTEMS AND PERMISSIBLE VOLTAGE

4.1.1 The following systems of electrical power distribution may be used on board the MODU:

.1 for alternating current over 1000 V (up to 15000 V inclusive) – 50 Hz or 60 Hz:
three-phase three-wire insulated system;
three-phase three-wire insulated system with the zero point earthed via a high-value resistor or reactor;

.2 or alternating current up to 1000 V – 50 Hz or 60 Hz:
three-phase three-wire insulated system;
three-phase three-wire insulated system with the zero point earthed via a high-value resistor or reactor;

.3 for alternating current up to 500 V inclusive – 50 Hz or 60 Hz:
as specified in [4.1.1.2](#);
three-phase four-wire insulated system;
single-phase two-wire insulated system;
single-phase single-wire system with the unit's hull return for voltage up to 30 V only, except for a supply system of navigation lights, provided that any possible current will not pass directly through any of hazardous spaces;

.4 for direct current up to 1000 V:
two-wire insulated system;
single-wire (only for voltage up to 50 V for local earthed systems, e.g. for starter systems of internal combustion engines) system with the unit's hull return, provided that any possible current will not pass directly through any of hazardous spaces.

4.1.2 Every insulated distribution system, irrespective of whether it is primary or secondary, power, lighting or heating one, shall be provided with audible and visual alarms actuated on the drop of insulation resistance below the set level.

4.1.3 Permissible voltage across the terminals of sources of electrical power with frequency of 50 Hz or 60 Hz shall not exceed the values specified in [4.1.1](#) depending on the electrical power distribution system adopted.

4.1.4 Permissible voltage across the terminals of direct current sources shall not exceed the following values:

- 500 V for power systems;
- 250 V for lighting and heating systems, and for socket outlets.

4.1.5 Permissible voltage across the terminals of consumers shall not exceed the values specified in [Table 4.1.5](#).

Additional requirements for networks for voltage over 1000 V are specified in [Section 18](#).

Table 4.1.5

Nos	Consumers	Permissible voltage, V
	Alternating current	
1	Permanently installed power consumers, cooking and heating appliances permanently installed in spaces other than those specified in item 2	1000
2	Portable power consumers supplied from socket outlets fixed in position when used, cooking and heating appliances installed in cabins, mess-rooms and other similar spaces for personnel	500
3	Lighting, alarms, intercommunication, socket outlets for supply of portable consumers with double or reinforced insulation or isolated electrically by means of an isolating transformer	250

Nos	Consumers	Permissible voltage, V
4	Socket outlets fitted in locations and spaces with elevated humidity or in extra humid spaces, and intended for supply of portable consumers having no double or reinforced insulation, or not isolated electrically	50
	Direct current	
5	Fixed power consumers	500
6	Heating, cooking, etc., appliances	250
7	Lighting, socket outlets	250

Note. In spaces with elevated humidity and in extra humid spaces, notices shall be provided at socket outlets with voltage above the safety one to notify of the use of consumers with double or reinforced insulation or of those electrically isolated from overrating voltage.

4.2 POWER SUPPLY OF ESSENTIAL SERVICES

4.2.1 The following consumers relating to essential ones shall be supplied by separate feeders from the main switchboard busbars:

- .1 electric drives of MODU steering gears and anchor arrangements;
- .2 electric drives of fire pumps, sprinkler system pumps and compressors;
- .3 bilge pump electric drives;
- .4 electric drives of the machinery serving main machinery operation;
- .5 switchboards of electric drives for cargo, mooring, lifeboat and other essential services intended for life-saving appliances and personnel evacuation;
- .6 electric drives of jacking mechanisms of self-elevating MODU, and of submersion and raising mechanisms of semi-submersible MODU;
- .7 electric drives of hazardous spaces and zones fans, of fans for equipment with the explosion protection type "pressurized enclosure";
- .8 electric drives of the machinery supporting process equipment (i.e. machinery intended for performance of MODU main functions);
- .9 electric drives of exciter sets of the MODU electric propulsion plant or the unit as a whole;
- .10 dynamic positioning systems equipment (thrusters and their control systems);
- .11 emergency switchboard under normal conditions of MODU operation;
- .12 gyrocompass (from an uninterruptible power supply system);
- .13 main lighting system (via appropriate transformer equipment);
- .14 radio station switchboard (from an uninterruptible power supply system);
- .15 navigational equipment switchboard (from an uninterruptible power supply system);
- .16 switchboard of navigation lights and warning flashing lights, and switchboard of electrical sound signal devices (from an uninterruptible power supply system);
- .17 section switchboards and switchgears for supplying other essential consumers combined on the principle of homogeneity of their functions;
- .18 distribution switchboards of an integrated bridge control console (refer also to [4.4](#));
- .19 switchboard of an automatic fire detection and fire alarm system, and of a warning alarm of fire-smothering medium release (from an uninterruptible power supply system);
- .20 charging facilities of starter accumulator batteries and batteries supplying essential services and relating to an uninterruptible power supply system;
- .21 switchboards of electric drives for closing of watertight doors, and of devices holding fire doors in open position, and also switchboards of the alarm of watertight and fire doors position and closure (from an uninterruptible power supply system);
- .22 switchboard of a refrigerating plant for a low-pressure carbon dioxide smothering system;
- .23 lighting switchboards for hangars and helidecks illumination;
- .24 other consumers not listed above as required by the Register.

4.2.2 Where one-purpose machinery with electric drives specified in [4.2.1](#) is installed in double or greater number, at least one of those electric drives shall be supplied by a separate feeder from the main switchboard. Electric drives of the rest of such machinery may be supplied from section switchboards or from special switchboards intended for supply of essential consumers.

4.2.3 Electric drives, section switchboards, special distribution devices or boards installed in double or greater number or supplied by two feeders shall be connected to different sections of the main switchboard (refer to [3.5.5](#)).

4.3 POWER SUPPLY OF ELECTRICAL (ELECTRONIC) AUTOMATION SYSTEMS

4.3.1 Power supply of electrical and electronic automation systems shall meet the requirements of Section 3, Part XIV "Automation" of the MODU Rules.

4.3.2 Power supply of automation devices necessary for starting and operating an emergency diesel- generator shall be effected from a starter battery or another independent accumulator battery located in the emergency diesel-generator space.

4.4 POWER SUPPLY OF INTEGRATED BRIDGE CONTROL CONSOLE

4.4.1 Distribution switchboards of an integrated bridge control console shall be supplied from the main switchboards directly or via transformers by two independent feeders connected to different sections of the main switchboard busbars, or by one feeder from the main switchboard or from the emergency switchboard.

4.4.2 Distribution switchboards of an integrated bridge control console shall be independently supplied by a separate feeder from other source or sources of power as well, where necessary, basing on the requirements for the equipment fed from those switchgears, or according to other technical reasons.

4.4.3 The distribution switchboard shall be provided with a change-over switch for feeders.

Where an automatic change-over switch is used, manual switching-over of feeders shall be also ensured. In this case, provision shall be made for necessary interlocking.

4.4.4 Each consumer specially listed in [4.2.1](#) fed from switchgears of an integrated bridge control console shall be supplied by a separate feeder.

4.4.5 A visual alarm of presence of supply voltage in each potential feeder shall be fitted in an integrated bridge control console.

4.5 SWITCHBOARDS AND SWITCHGEARS

4.5.1 Switchboard design and construction.

4.5.1.1 Frames, front panels and enclosures of main, emergency, section and distribution switchboards shall be made of metal or some other durable non-combustible material. Generator sections of the main switchboard shall be separated from each other or from other sections with non-combustible bulkheads preventing spread of sparks and flame.

4.5.1.2 Switchboards shall have a sufficiently rigid structure, which can withstand mechanical stresses liable to occur under operational conditions or due to short circuits.

4.5.1.3 Switchboards shall, at least, be protected against drip. This protection is not required if the switchboards are to be located in spaces where vertically falling drops of liquid cannot get into the switchboard.

4.5.1.4 Switchboards to be installed in locations accessible to unauthorized persons shall be provided with doors being opened with a special key, which is the same for all the switchboards on board the MODU.

4.5.1.5 The design of switchboard doors shall be such that with the doors opened, access to all parts needing maintenance is ensured, and the live parts fitted on the doors shall be protected against inadvertent touching.

Opening panels and doors used for mounting electrical control gear and measuring instruments shall be securely earthed with at least one flexible jumper. Where the opening parts of switchboards are made of dielectric material, the gears and instruments shall be earthed.

4.5.1.6 Handrails shall be fitted to main, emergency and section switchboards and to control panels on their front side. Switchboards accessible from the rear shall be provided with horizontal handrails fitted at the back. The materials, which may be used for manufacture of handrails, are insulating material, wood or metal pipes with appropriate insulating covering.

4.5.1.7 The generator panels of main switchboards shall be illuminated with lighting fixtures supplied on the generator side before the main breaker of the generator or not less than from two different systems of busbars.

4.5.1.8 The lighting of the front side of switchboard panels shall not interfere with instrument observation or produce a blinding effect.

4.5.1.9 The design of switchboards, which have no space at the rear shall be such that the access to all parts requiring maintenance is ensured.

Arrangements shall be provided for doors of switchboards and distribution cabinets to fix them in the open position. Withdrawable blocks and instruments shall be fitted with devices preventing their fall-out when withdrawn.

4.5.1.10 Each distribution switchboard designed for voltage over the safety one, with switching and protective devices and not fitted with a voltmeter, shall be provided with a pilot lamp indicating the presence of voltage on busbars.

4.5.2 Busbars and uninsulated conductors.

4.5.2.1 The ultimate heating temperature of switchboard busbars and uninsulated conductors at the rated load and short circuit or at the permissible one-second short-circuit load for copper busbars shall be determined according to national standards.

4.5.2.2 Equalizer busbars shall be designed for at least 50 % of the rated current of the largest generator connected to the main switchboard.

4.5.2.3 Where a busbar is in contact with or close to insulated parts, its heat effects shall not cause under operating or short-circuit conditions a temperature rise in excess of that allowable for a given insulating material.

4.5.2.4 Busbars and uninsulated conductors in distribution switchboards shall have electrodynamic and thermal stability during short-circuit currents occurring at relevant points in the circuit. Electrodynamic loads as occur in busbars and uninsulated conductors due to short circuit shall be determined according to national standards.

4.5.2.5 Insulators and other parts for fastening busbars and uninsulated conductors shall withstand loads due to short circuits.

4.5.2.6 The natural frequency of copper tier busbars shall be outside the ranges of 40 to 60 Hz and 90 to 110 Hz for the rated frequency of 50 Hz, and of 50 to 70 Hz and 110 to 130 Hz for the rated frequency of 60 Hz.

4.5.2.7 Busbars and uninsulated conductors of different polarity shall be marked with the following distinctive colours:

- red for positive pole;
- blue for negative pole;
- black or green and yellow (cross stripes) for earth connections;
- light blue for middle wire.

The equalizer connection shall be marked with white cross stripes in addition to the appropriate colour as given above.

4.5.2.8 Busbars and uninsulated conductors of different phases shall be marked with the following distinctive colours:

- yellow for phase 1;
- green for phase 2;
- violet for phase 3;
- light blue for neutral wire;
- green and yellow (cross stripes) for earth connections.

4.5.2.9 Busbars shall be connected so as to prevent corrosion in way of their connections.

4.5.3 Calculation of short-circuit currents and selection of electrical switch apparatus.

4.5.3.1 Electrical switch apparatus shall, at least, comply with national standards and shall be so selected that:

under normal operational conditions their rated voltages, currents and temperature rise limits are not exceeded;

they are capable of withstanding, without damage or exceeding temperature limits, such overloads as specified for transient conditions;

their characteristics under short-circuit conditions are consistent with the actual short-circuit power factor as well as with the behavior of the subtransient and transient short-circuit current.

4.5.3.2 The rated breaking capacity (I_{cn}) of electrical switch apparatus designed to break short-circuit currents shall not be less than:

actual value of the periodic component of the prospective short-circuit current for alternating current (I_{ac});

the prospective short-circuit current at the specified time constant of the direct current apparatus at the place of their installation at disconnection.

4.5.3.3 The rated making capacity (I_{cm}) of electric switch apparatus, which may be incorporated in a shorted electric circuit, shall be not less than the peak prospective short-circuit current (I_p) at the place of their installation.

4.5.3.4 The electrodynamic ability current of electric switch apparatus not intended for interrupting short-circuit currents shall not be less than the peak prospective short-circuit current (I_p) at the place of their installation.

4.5.3.5 Thermal strength of electric switch apparatus under short-circuit condition shall be consistent with the thermal action of periodic component of the prospective short-circuit current (root-mean square (r.m.s.)) (I_{ac}) at the place of their installation during short-circuit specified by the selective action of protective devices.

Note. Thermal strength of electric switch apparatus is determined as the product of squared r.m.s. value of the periodic component prospective short-circuit current, kA, by the time, s, $I^2 \times t$ and shall be indicated in its technical specifications.

4.5.3.6 Rated short-time withstand current (I_{cw}) for electric switch apparatus in circuits with selective action of protective devices shall be not less than the r.m.s. periodic component of the prospective short circuit current at the first half-cycle ($I_{cw} > I_{ac}$).

4.5.3.7 The use of a circuit-breaker with an inadequate rated service ultimate breaking capacity (I_{cs}) and rated ultimate making capacity (I_{cm}) corresponding to the prospective peak short-circuit current at the point of its installation is allowed, provided it is protected on the generator side by means of fuses and/or a circuit breaker with, at least, necessary ratings for short-circuit currents, which is not used as a generator automatic switching device.

Such protective devices having only rated ultimate breaking capacity (I_{cu}) shall not be installed on the main and emergency switchboards and shall not be applied in the circuits of essential and emergency consumers. Their characteristics shall be such that:

.1 while breaking the prospective peak short-circuit current, the circuit breaker on the load side will not be so damaged as to become unfit for further service;

.2 switching the circuit breaker on the prospective peak short-circuit current will not result in damage to the remaining part of the electrical installation; in this case, it is allowed for the circuit breaker on the load side not to be immediately fit for further service.

4.5.3.8 In electric circuits having a current rating in excess of 320 A, circuit breakers shall be fitted for overload protection. The use of automatic circuit breakers is recommended at the current exceeding 200 A.

4.5.3.9 In direct current compound generator circuits, where the generators are intended for parallel operation, circuit breakers shall have a pole for a common-wire mated mechanically with the other poles of the circuit breaker so it would switch on before the other poles are connected to the busbars and switch off after their disconnection.

4.5.3.10 Short-circuit currents shall be calculated on the basis of standards or calculation methods approved by the Register.

4.5.3.11 In calculations of peak short-circuit currents, an equivalent short-circuit current source shall contain all generators including synchronous compensators which may be connected in parallel and all electric motors running simultaneously. Currents from generators and electric motors shall be calculated on the basis of their parameters.

When the precise data are lacking, the following ratios of the actual current contribution of the short-circuit point shall be taken for alternating current electric motors:

at the instant of short-circuit occurrence – $6,25 I_r$;

at the instant T , i.e. after one cycle from short-circuit inception – $2,5 I_r$,

at the instant $2T$, i.e. after two cycles from short-circuit inception – I_r ;

for peak current – $8 I_r$;

(I_r = total rated current of the electric motors running simultaneously under design conditions).

For the evaluation of the peak value of short-circuit current in direct current systems, the value of electric motor contribution current is taken to be equal to the six-fold sum of the rated currents of electric motors running simultaneously under design conditions.

The calculation of short-circuit currents shall be made for all design short-circuit points which are necessary for the selection and test of power electric circuit elements. In any case, the calculation of short-circuit currents shall be made for the following design points:

on the generator side – on the circuit breaker terminals;

on collecting busbars of the main switchboard;

on busbars of the emergency switchboard;

on the terminals of the consumers and busbars of the switchboards supplied directly from the main switchboard.

The calculation of the minimum short-circuit current shall be made if it is required for the assessment of the installation protection sensitivity.

The calculation of short-circuit currents shall include the list of all switching devices fitted, with indication of their characteristics, and also the prospective short-circuit current at the points of their installation.

4.5.4 Electric switch apparatus and instrumentation.

4.5.4.1 Apparatus, measuring and indicating instruments used in connection with generators and other large essential installations shall be fitted on the switchboards associated with the appropriate generators and installations.

This requirement may be dispensed with in the case of generators where there is a central control console with switch gear and measurements for several generators.

4.5.4.2 One ammeter and one voltmeter shall be provided for each direct-current generator on the main and emergency switchboards.

The following instruments shall be provided for each alternating current generator on the main switchboard and for an emergency generator on the emergency switchboard:

- .1 an ammeter with a selector switch for current measurements in each phase;
- .2 a voltmeter with a selector switch for measuring phase or line voltages;
- .3 a frequency indicator (use of one double frequency indicator is allowed for generators running in parallel with change-over to each generator);
- .4 a wattmeter (for output over 50 kVA);
- .5 other instruments as required.

4.5.4.3 Where the circuit breakers with control blocks being capable of outputting separate parameters to a built-in monitor are used on the main or emergency switchboards for the connection and protection of powerful consumer generators or section switchboards, it is allowed not to install the relevant measuring instruments.

4.5.4.4 Ammeters shall be installed in the circuits of essential consumers rated at 20 A and over. These ammeters may be fitted on the main switchboard or at control stations. It is allowed to install ammeters with selector switches but not more than for six consumers.

4.5.4.5 On the main switchboard, each feeder energized from the external source of electrical power shall be provided with:

- .1 switchgear and protective devices;
- .2 a voltmeter or a pilot lamp;
- .3 means of protection against phase breaking.

4.5.4.6 A change-over arrangement or a separate device for measuring insulation resistance shall be installed on the main and emergency switchboards for each isolated distribution system. In any case, the hull leakage current due to the operation of a measuring device shall not exceed 30 mA.

Provision shall be made for visual and audible alarms to warn of inadmissible insulation resistance decrease with the output to the main control station over an electric generating system.

4.5.4.7 Measuring instruments shall have scales with a margin of divisions, which exceeds the rated values of quantities to be measured.

The upper scale limits of the instruments shall be not less than:

- .1 for voltmeters – 120 % of the rated voltage;
- .2 for ammeters associated with generators not running in parallel and with current consumers – 130 % of the rated current;
- .3 for ammeters associated with parallel-running generators – 130 % of the rated current for a load-current scale and 15 % of the rated current for a reverse-current scale (the last refers to direct current generators only);
- .4 for wattmeters associated with generators not running in parallel – 130 % of the rated output;

.5 for wattmeters associated with parallel-running generators – 130 % for power scale and 15 % for reverse power scale;

.6 for frequency indicators – ± 10 % of the rated frequency.

4.5.4.8 Voltage, current and power ratings of generators shall be clearly marked on the scales of measuring instruments.

4.5.4.9 Wherever possible, switchgear shall be installed and connected to busbars in such a way that none of movable contacts and protective or control devices associated with the switchgear is not energized in the position "OFF".

4.5.4.10 Where switches with fuses are installed in outgoing circuits of switchboard, the fuses shall be positioned between busbars and the switch.

4.5.4.11 Where switchboards are installed on a foundation at the floor level, the fuses shall be located not lower than 150 mm and not higher than 1800 mm from the floor level.

Live open parts of switchboards shall be located at a height of not less than 150 mm above the floor level.

4.5.4.12 Fuses shall be so installed on switchboards that they are easily accessible and the fuse link replacement is safe for attending personnel. Screwed-in fuses shall be so fitted that feeders could be connected to the central, less accessible, terminal.

4.5.4.13 The fuses protecting the poles or phases of the same circuit shall be installed in a row, horizontally or vertically depending on the fuse design. The fuses in an alternating current circuit shall be positioned to follow the sequence of phases from left to right or from top to bottom.

In direct current circuit, the positive-pole fuse shall be on the left, at top or closer to reach.

4.5.4.14 The manual actuators of voltage regulators installed in main or emergency switchboards shall be positioned close to the measuring instruments associated with the relevant generators.

4.5.4.15 The ammeters of direct current compound generators intended for running in parallel shall be included in the circuit of the pole not connected to the common wire.

4.5.4.16 For connecting movable or semi-movable instruments, flexible stranded conductors shall be used.

4.5.4.17 Switch electrical apparatus controls, instruments, panels and outgoing circuits on switchboards shall have their designations marked. The apparatus switching positions ("ON", "OFF") shall be also indicated. In addition, markings shall be provided to indicate the rated currents of fuses fitted, and the settings of circuit breakers and electrothermal trips.

4.5.4.18 Each outgoing circuit in a switchboard shall be provided with a breaker to disconnect all poles and/or phases. Breakers may be dispensed with in secondary light distribution boxes provided with a common breaker, and also in the circuits of instruments, interlocking and alarm devices, and of local lighting of switchboards protected with fuses.

4.5.5 Visual signals.

4.5.5.1 Visual signals shall be of the colour specified in [Table 4.5.5.1](#).

Table 4.5.5.1

Colour	Meaning	Signal type	Object condition
Red	Danger	Blinking	Alarm in dangerous conditions, detected, but not yet rectified
		Continuous	Alarm in dangerous conditions where immediate action is necessary
Yellow (orange)	Attention	Blinking	Abnormal conditions where immediate action is not required

		Continuous	Intermediate condition between abnormality and safety. Abnormal condition already detected, but not yet rectified
Green	Safety	Blinking	Standby machinery is put into operation
		Continuous	Rated conditions of running and operation
Blue	Information	Continuous	Machinery and gear are ready to be started. Voltage in mains. Everything is in order
White	General information	Continuous	Signals switched on when necessary. Notations relating to automatic control conditions. Other auxiliary signals

4.5.6 Arrangement of distribution switchboard.

4.5.6.1 Main and section switchboards, and other distribution switchboard shall be installed in locations where possible concentration of gases, petroleum and water vapours, dust and acid evaporations is eliminated.

4.5.6.2 Where the switchboard having protective enclosure of IP10 type and below is located in a special space, cabinet or recess, such spaces shall be made of non-combustible material or shall have a lining of such material.

4.5.6.3 Arrangement of pipelines and tanks near the switchboards shall meet the requirements of Part VIII "Systems and Piping" of the MODU Rules.

4.5.6.4 Generator sets and the main switchboard connected to them shall be located in one space or in one main vertical fire zone.

Recesses for the main switchboard, main control station or other special electrical rooms within the main boundaries of machinery space are not considered as separating them from generator sets.

4.5.7 Access to switchboards.

4.5.7.1 In front of the main, emergency and other switchboards, a passageway shall be provided not less than 1000 mm wide for switchboards 3 m long and over. In front of the main and emergency switchboards, a passageway shall be provided not less than 800 mm wide for switchboards up to 3 m long and on ships of less than 500 gross tonnage, the passageway shall be at least 600 mm wide.

If withdrawable arrangements are provided in front of the main and emergency switchboards, the free space in the passageway shall be not less than 400 mm wide from the most protruding parts of this arrangement in completely withdrawn position.

In any case, if opening swing panels are located in front of the switchboard, the width of the passageway shall be sufficient for switchboard maintenance with the panel at a fully open position.

4.5.7.2 Behind the free standing main and emergency switchboards, it is necessary to provide a passageway not less than 600 mm wide. In case of passageway narrowing caused by location of hull framing (frames, stiffeners, etc.) behind the main or emergency switchboard, the width of passageway at the narrowing point may be reduced down to 500 mm.

In any case, if opening swing panels are located behind the switchboard, the width of the passageway shall be sufficient for switchboard maintenance with the panel at a fully open position.

Between the free-standing switchboards with open live parts and located in special electrical rooms, a passageway shall not be less than 1000 mm wide.

4.5.7.3 The space behind the free-standing switchboards with open live parts shall be enclosed and provided with doors in accordance with [2.8.1](#).

4.5.7.4 For switchboards of more than 3 m long, at least two doors shall be provided leading from the space where the switchboard is installed into the space behind the switchboard. These doors shall be as widely spaced as possible.

It is allowed for one of these doors to be opened into the adjacent space having at least another exit.

4.5.7.5 The passageways specified in [4.5.7.1](#) and [4.5.7.3](#) are measured from the most protruding parts of apparatus and switchboard structures to the protruding parts of equipment or hull structures.

4.5.7.6 Dielectric mats shall be placed in passageways in front of and behind switchboards.

4.5.7.7 Additional requirements for arrangement of distribution switchboard for voltage over 1000 V are given in [Section 18](#).

5 ELECTRIC DRIVES OF MACHINERY AND ARRANGEMENTS

5.1 GENERAL

5.1.1 The local control stations of drives and the power supply of electrical (electronic) automation systems shall meet the appropriate requirements of Part VII "Machinery Installations and Machinery" and of Part XIV "Automation" of the MODU Rules, respectively.

5.1.2 Electrically-driven machinery shall be provided with visual signals to indicate switching-on of the electric drive.

5.1.3 Equipment provided with automatic, remote and local control shall be so designed that the automatic and remote control is switched off when the change-over to the local one occurs. The local control shall be independent both of the automatic or remote one.

5.2 INTERLOCKING OF MACHINERY OPERATION

5.2.1 The machinery provided with electric and manual drives shall be fitted with an interlocking device that prevents possible simultaneous operation of the drives.

5.2.2 If the machinery is required to operate in a certain sequence, appropriate interlocking devices shall be used.

5.2.3 A device may be installed that switches off the interlocking on condition that this device is protected against inadvertent (accidental or unauthorized) use. Information inscription shall be placed in close proximity to this device indicating its application and forbidding its use by unauthorized personnel.

Such a device is not permitted for machinery specified in [5.2.1](#).

5.2.4 Starting of the machinery which electric motors or switchgear require additional ventilation in normal operation shall be possible with ventilation in action only.

5.3 SAFETY TRIPPING DEVICES

5.3.1 Control systems of machinery, which operation under certain conditions may endanger the human or unit safety, shall be provided with safety tripping devices ensuring the safe trip of the electric drive from the power supply.

The safety tripping devices (push-buttons, tumblers, etc.) shall be suitably protected against inadvertent actuation.

5.3.2 Push-buttons or other safety tripping devices shall be located near control stations or in other places ensuring safety of operation.

5.3.3 Electric drives of arrangements and machinery, which require restriction of motion to prevent damage or break-down, shall be provided with limit switches to ensure reliable trip of the electric motor.

5.4 SWITCHGEAR AND CONTROL GEAR

5.4.1 The switchgear in the circuits of electric drives, which in itself does not provide for short-circuit protection, shall withstand the short-circuit current that may flow at the point of its installation during the time required for actuation of a protective device.

5.4.2 Starting of an electric motor shall be possible only from the zero position of the control gear.

5.4.3 A field killing device shall be provided for the control gear that permits isolation of shunt field windings.

5.4.4 For each electric motor rated at 0,5 kW and more and its control gear, provision shall be made for fitting a device to isolate the power supply; where the control gear is mounted on the main switchboard or on any other switchboard in the same compartment and its visibility from the place of electric motor installation is ensured, then for this purpose, it is permitted to use a switch mounted on the switchboard.

If the requirements in respect of location of machine control gear stated above are not met, the following shall be provided:

- .1** a device interlocking the switch on the switchboard in the "OFF" position; or
- .2** an additional disconnecting switch near the electric motor; or
- .3** fuses in each pole or phase of the control gear arranged in such a manner that they could be readily removed or replaced by the personnel.

5.5 ELECTRIC DRIVES OF PUMPS

5.5.1 The electric motors of fuel and oil transfer pumps and separators shall be provided with remote disconnecting switches located outside the spaces wherein these pumps are placed and outside the machinery casings, but in close vicinity of the exits from those spaces.

5.5.2 The electric motors of the pumps transferring the liquids overboard through the drain holes above the lightest waterline at locations where lifeboats or liferafts are launched, shall be provided with disconnecting switches placed near the control stations of launching appliance drives for the relevant lifeboats or liferafts.

5.5.3 The electric motors of submersible bilge and emergency fire and ballast pumps shall be provided with remote starting devices located above the bulkhead deck. The remote starting devices shall be provided with a visual signal indicating the "ON" condition of the electric drive.

5.5.4 The disconnecting switches of electric drives specified in [5.5.1](#) shall be located in conspicuous places, protected against an inadvertent action and provided with explanatory inscriptions.

5.5.5 Local starting of fire, ballast and bilge pumps shall be possible even in case of failure of their remote control circuits.

5.5.6 The electric motors of fire, ballast and bilge pumps (at least one from each pair) shall be supplied through an emergency switchboard and be capable of functioning in case of failure of power supply from the main source of electrical power.

5.5.7 Cables and cable entries of submersible pumps shall be appropriately protected against mechanical damages and shall be functional at the maximum pressure of a water column for the deepest waterline when the MODU hull is damaged.

5.5.8 The electric motors of oily water or sewage transfer or discharge pumps shall be provided with remote cut-off arrangements located in the vicinity of discharge manifolds.

5.6 ELECTRIC DRIVES OF ANCHOR AND MOORING MACHINERY

5.6.1 In addition to the requirements of Part VII "Machinery Installations and Machinery" of the MODU Rules, the drive of windlasses, anchor and mooring capstans, and mooring winches shall meet the requirements of this Part.

5.6.2 When alternating current squirrel-cage electric motors are used, the electric drives of anchor and mooring machinery shall ensure, after 30-minute operation at the rated load, possible stalling of the electric motor in "ON" position at the rated voltage for at least 30 s for the anchor machinery and 15 s for the mooring machinery. For pole-changing motors, this requirement is applicable to operation of motors with the winding producing the maximum starting torque.

The direct current electric motors and alternating current wound-rotor electric motors shall withstand the above stated stalling conditions, but at the torque twice that of the rated value with the voltage which may be below the rated value.

After stalling conditions, the temperature rise shall not be over 130 % of the permissible value for the insulation used.

5.6.3 In anchor and mooring capstans and mooring winches, provision shall be made for overload protection of the electric motor at the speed steps intended only for mooring operations.

5.7 ELECTRIC DRIVES OF FANS

5.7.1 The electric motors of ventilation fans in machinery spaces and in spaces associated with hazardous zones shall have at least two disconnecting switches with one of them located outside these spaces or their casings, but in close vicinity of the exits from these spaces.

5.7.2 The electric motors of ventilation fans of cargo holds, other technological spaces, and also of galley fans shall have disconnecting switches placed at locations readily accessible from the deck, but outside machinery casings.

The electric motors of exhaust ventilation from galley ranges shall be provided with a disconnecting switch located inside the galley, regardless of the number of disconnecting switches.

5.7.3 The electric motors of accommodation and service spaces fans shall be provided with at least two switches for remote disconnection of motors with one of the switches located in the bridge control station and another accessible from the open deck.

5.7.4 The electric motors of fans in the spaces protected by a smothering system shall have a disconnecting switch automatically actuated when fire extinguishing medium is discharged in to the space.

5.8 ELECTRIC DRIVES OF BOAT WINCHES

5.8.1 The electric drive of a boat winch shall meet the requirements of Part II "Life-Saving Appliances" of the RS Rules/E.

5.8.2 The winch electric drive controls shall be provided with self-return to the "Stop" position.

5.8.3 A switch in power circuit of the electric motor shall be installed near the boat winch control station.

5.9 ELECTRIC DRIVES OF WATERTIGHT AND FIRE DOORS

5.9.1 The electric drives of watertight doors shall meet the requirements of Part III "Equipment, Arrangements and Outfit" of the MODU Rules.

5.9.2 Power supply of electric drives and indicators of open and closed positions of watertight doors shall be effected from the main, emergency and emergency transitional sources of electrical power in accordance with the requirements of [4.2](#) and [9.3](#).

5.9.3 The electric drives of devices for holding fire doors in the open position (refer to Part VI "Fire Protection" of the MODU Rules) shall:

- .1** be supplied from the main and emergency sources of electrical power;
- .2** be remotely controlled from the bridge and reserve control stations of the unit for closing the doors individually, in groups or all doors simultaneously;
- .3** automatically close all the doors simultaneously in case of the supply voltage loss;
- .4** be so designed that any damage to the mechanism of closing any door could not render inoperative the supply and control systems of other doors.

5.10 ELECTRIC DRIVES OF SELF-PROPELLED MODU STEERING GEAR

5.10.1 The main and auxiliary steering gear needed to steer the MODU, shall be provided with electric or electro-hydraulic drives.

5.10.2 The electric systems of main and auxiliary steering gear shall be so designed that any malfunction in one system could not disable another. The very principle shall be used when two or more similar sets are installed instead of the main and auxiliary drives of the steering gear.

5.10.3 The parameters and power of the electric motor of the steering gear shall be determined with regard to the required break and maximum working torque of the drive for all potential operational conditions. The ratio of a tilting moment to a rated one shall be at least 1,6.

5.10.4 Each electric motor of the main and auxiliary steering gear shall have its own starter located in the unit's steering compartment. The starters may be fitted in switchboard spaces where they are supplied from.

5.10.5 Each electric or electro-hydraulic drive comprising one or more power units shall be supplied by two feeders from the main switchboard laid in different cable runs spaced as far as possible. One of these feeders shall be supplied from the emergency switchboard. The auxiliary electric or electro-hydraulic drive may be supplied from the main drive feeder.

5.10.6 Each feeder shall be selected so as to supply all the electric motors and control gear, which are normally connected thereto and may operate simultaneously.

5.10.7 In the event of failure of the main source of electric power of the steering gear power unit, provision shall be made for automatic connection within 45 s to the emergency source of electrical power or to another independent source located in the steering gear compartment and intended only for this purpose.

5.10.8 Each start-stop system of electric drives shall be supplied from the relevant electric motor feeders.

5.10.9 Electric drive control systems of a steering gear shall be supplied by separate feeders laid in different cable runs from the relevant starters in a steering gear compartment, or from the busbars of distribution switchboard supplying power circuits of the steering gear.

5.10.10 Short-circuit protection only shall be provided for each power and control circuits. No other types of protection shall be provided.

Overcurrent protection may be allowed if it comes into action not less than at the twofold rated current with the relevant time delay. That protection shall not be actuated by starting currents of electric motors.

5.10.11 Starting and stopping of the steering gear electric motors shall be effected from the wheelhouse and from the steering room. Provision shall be made in the steering room for switches disconnecting remote starting and stopping, and ensuring switching-on of the motors at any malfunction of remote control. Starting devices shall ensure automatic restarting of the electric motors as soon as the voltage is restored after a discontinuity in power supply.

5.10.12 The control system of the main steering gear shall provide for an opportunity of control both from the wheelhouse and from the steering room. The same is also true for the control system of the auxiliary drive for the steering gear, and both control systems shall be independent of one another.

5.10.13 Where a steering gear with two or more identical electric drives is installed, at least two independent control systems being capable of ensuring control both from the wheelhouse and from the steering room shall be provided. In this case, no handwheel or other controls duplication is needed. If the control system is provided with a hydraulic setting mechanism, its duplication is not required as well.

5.10.14 In the wheelhouse and at the propulsion plant control station in the machinery space, visual and audible alarms shall be given in the event of:

- .1** supply voltage loss, phase break-off and power circuit overload of each power unit;
- .2** supply voltage loss in the power circuit of each control system;

.3 low oil level in each hydraulic system tank.

In addition, light indication of steering gear power units operation shall be provided.

5.10.15 A rudder position indicator shall be provided in a wheelhouse. This device shall be independent of steering gear power units and their control systems. The device shall be supplied from an emergency switchboard or from other independent source of electrical power, e.g. from other continuous supply system. Rudder position indication shall be also provided in the wheelhouse, but it may be of the non-electrical type.

5.10.16 Duplicated power circuits and the relevant control systems of steering gear with their components in control cabinets and panels shall be physically separated from each other as far as possible. The relevant cables shall be laid in different cable runs spaced as much as possible, both in the vertical or in the horizontal, along their entire length.

5.11 ELECTRIC DRIVES FOR OIL BURNER UNITS OF BOILERS AND INCINERATORS

5.11.1 Electric drives for oil burner units, boilers and incinerators shall be provided with remote shut-off devices located outside the spaces, in which they are installed (refer also to 5.3.8, Part X "Boilers, Heat Exchangers and Pressure Vessels" of the Rules for the Classification and Construction of Sea-Going Ships¹ and 4.3.4, 4.3.5 and 6.3.1, Part XIV "Automation" of the MODU Rules).

5.11.2 Where the spaces in which the incinerators and boilers are installed are protected by aerosol fire extinguishing system, the electric drives for oil burner units of boilers and incinerators shall be automatically shut off when the above system is activated.

¹ Hereinafter referred to as "the RS Rules/C".

6 LIGHTING

6.1 GENERAL

6.1.1 All spaces, locations and areas of the unit where the illumination is essential for personnel safety, control of machinery and gear, people habitability and evacuation shall be provided with stationary main lighting fixtures supplied from the main source of electrical power.

6.1.2 The list of spaces, locations and areas where the emergency lighting fixtures shall be installed in addition to the main ones are given in [9.3.1.1](#).

Lighting fixtures installed in spaces and areas with potential mechanical damage to their glass hoods shall be provided with protection gratings.

6.1.3 Lighting fixtures shall be installed in such a manner as to prevent heating of cables and adjacent materials up to the temperature exceeding the permissible level.

6.1.4 In spaces and locations illuminated with luminescent lamps where visible rotating parts of machinery are located, all measures shall be taken to prevent a stroboscopic effect.

6.1.5 In spaces and areas illuminated with discharge lamps which do not ensure continuity of burning at voltage variations according to [2.1.3](#), provision shall be also made for lighting fixtures with incandescent lamps.

6.1.6 Battery and other hazardous spaces and areas shall be illuminated with lighting fixtures, located in adjacent safe spaces, through gastight glazed windows or with safe-type lighting fixtures located inside the spaces.

6.2 POWER SUPPLY OF MAIN LIGHTING ELECTRIC CIRCUITS

6.2.1 The switchboards of the main lighting shall be supplied by separate feeders. The main lighting switchboards may supply the electric drives of non-essential services rated up to 0,25 kW and individual cabin heaters rated up to 10 A.

6.2.2 The protective devices of final tapped-off lighting circuits shall be set to operate at a current rating not more than 16 A, the total load current of the consumers connected shall not exceed 80 % of the current setting of the protective device.

The number of lighting fixtures supplied by final lighting circuits shall not exceed that specified in [Table 6.2.2](#).

Table 6.2.2

Voltage, V	Maximum number of lighting fixtures
Up to 50	10
51 to 120	14
121 to 250	24

6.2.3 Lighting of open decks, machinery spaces, control station spaces, galleys of service and public spaces, corridors, stairways, tunnels, exits to an open deck etc. shall be supplied by not less than two independent feeders with the lighting fixtures arranged in such a manner that in case of failure of either feeder the above spaces and areas are not fully deprived of lighting, which shall be as uniform as possible. These feeders shall be supplied from different group boards, which, in their turn, shall be supplied from different sections of lighting subdivided busbars in the main switchboard.

6.2.4 Local lighting fixtures in accommodation spaces, as well as socket outlets shall take power from the lighting switchboard by a separate feeder, other than that intended for supplying the common lighting fixtures.

6.2.5 Lighting of spaces and areas of MODU each fire zone shall be supplied by two feeders independent of the feeders supplying the lighting circuits in other fire zones.

The lighting feeders, as far as practicable, shall be installed in such a manner that a fire in one zone cannot damage the lighting feeders supplying the lighting circuits in other zones.

In case of application of the lighting subdivided busbars in the main switchboard, these feeders shall be supplied from different busbar sections.

6.2.6 The main lighting circuits shall be so arranged that fire or other emergency in the spaces accommodating the main sources of electrical power and/or main lighting transformers, if any, will not cause failure to the emergency lighting.

6.3 EMERGENCY LIGHTING

6.3.1 The illumination in the separate spaces, locations and areas specified in [9.3.1.1](#) under emergency lighting shall be not less than 10 % of the general illumination under main lighting (refer to [6.7](#)). It is allowed that the illumination from emergency lighting fixtures in a machinery space accounted for 5 % of the main lighting illumination if the socket outlets fed from the emergency lighting circuit and intended for portable lighting fixtures are provided.

The illumination shall be sufficient to easily find one's way to the means of escape (or shall be equal to 0,5 lx).

6.3.2 To obtain the illumination specified in [6.3.1](#), the emergency lighting fixtures with incandescent lamps may be combined with luminescent lamps.

6.3.3 Main lighting fixtures are permitted for use as emergency ones if they may also be fed from emergency sources of electrical power.

6.3.4 The emergency lighting circuit shall be so designed that in case of fire or other emergency in the spaces accommodating the emergency sources of electrical power and/or emergency lighting transformers, the main lighting system will not fail.

6.3.5 For emergency lighting, use may be made of the stationary lighting fixtures with built-in accumulators and automatic recharging from the main lighting circuit.

6.3.6 Every emergency lighting fixture and combined lighting fixture, i.e. jointly with the emergency one, shall be marked red.

6.3.7 Low-location emergency lighting electrically-powered (if any).

6.3.7.1 The low-location lighting system shall be supplied from emergency switchboard busbars in such a manner that it is capable of functioning both under normal conditions, while main generators are operational, and under emergency conditions. The system shall be in continuous operation.

6.3.7.2 Low-location lighting shall ensure the following standards of luminance:

- .1** active system parts shall have the minimum luminance of 10 cd/m²;
- .2** the point sources of miniature incandescent lamps shall provide not less than 150 mcd mean spherical intensity with a spacing of not more than 100 mm between lamps;
- .3** the point sources of light-emitting diode systems shall have a minimum peak intensity of 35 mcd. The angle of half intensity spherical cone shall be appropriate to the likely track directions of approach and viewing. Spacing between the light-emitting diodes shall be not more than 300 mm.

6.3.7.3 The supply of a low-location lighting system shall be such that the failure of any light source and fire in one fire zone or on one deck will not result in the failure of lighting and escape route signs being ineffective in another fire zone or on the deck.

6.3.7.4 The failure of or damage to any light source shall not result in the loss of visible outline of the escape route at the length over 1 m.

6.3.7.5 The type of light source enclosure protection shall be at least IP55.

6.4 SWITCHES IN LIGHTING CIRCUITS

6.4.1 Two-pole switches shall be used in all lighting circuits.

In dry accommodation and service spaces it is allowed to use single-pole switches in circuits disconnecting individual lighting fixtures or groups of lighting fixtures rated at not more than 6 A and also of lighting fixtures rated for safety voltage.

6.4.2 For permanently installed external-illumination lighting fixtures, provision shall be made for centralized switching off all the lighting fixtures from the unit's bridge control station or from other manned station on the upper deck.

6.4.3 The switches of lighting circuits of the fire extinction stations shall be located outside these spaces.

6.4.4 The switches of lighting behind free-standing switchboards shall be fitted at each entrance behind the switchboard.

6.4.5 In emergency lighting circuits, local switches shall not be used. It is allowed to use local switches in the circuits of emergency lighting fixtures which, under normal conditions, serve as the main lighting fixtures.

The unit's bridge control station shall be provided with the switch of an emergency lighting system.

Emergency lighting fixtures of embarkation stations which, under normal conditions, serve as the main lighting fixtures shall switch on automatically when the main switchboard busbars are de-energized.

6.5 INCANDESCENT AND GAS-DISCHARGE LIGHTING FIXTURES

6.5.1 Lighting fixtures shall have such a design that cable entries are of a sufficient length and free from rough ledges, sharp angles and sudden bends. All exits for cables shall have well-rounded edges and shall be appropriately worked to prevent damage to a cable.

6.5.2 Insulated conductors shall be provided with an opportunity of being so connected to terminals that they could not contact other current-carrying elements inside a lighting fixture under vibration conditions.

6.5.3 Lighting fixtures shall be so designed that dust and moisture could not accumulate in their interior on current-carrying parts and insulation.

6.5.4 Current-carrying parts of lighting fixtures shall be reliably isolated from a housing or an enclosure.

6.5.5 All metal parts of lighting fixtures shall be electrically connected between themselves and the specially provided earthing terminal.

6.5.6 The components supporting current-carrying parts in tube retainers shall, as a minimum, be made of materials not maintaining burning and of non-combustible materials for luminescent and incandescent lamps, respectively.

6.5.7 The type of lighting fixture enclosure (case) shall be IP2X, as a minimum.

6.5.8 In lighting fixtures for spaces such as bathrooms, laundries, galleys and the like, the components of tube retainers which may be touched by personnel during lamp replacement shall be made of or covered with insulating material and provided with a protection shield.

6.5.9 Where lighting fixtures are supplied from a system with an earthed neutral, the external tube retainer contact shall be connected to a neutral conductor of a supply system.

6.5.10 Reactors and capacitors of gas-discharge lamp installations shall be protected securely with metal enclosures.

6.5.11 Capacitors of 0,5 μF and over shall be fitted with discharging devices. The discharging device shall be so designed that the voltage of the capacitor does not exceed 50 V in 1 min after disconnection from supply.

6.5.12 Reactors and transformers having a high inductive reactance shall be installed as close as possible to the lighting fixture they serve. The transformers shall have their primary and secondary windings electrically-separated and shall not include combustible materials and liquids.

6.5.13 Gas-discharge lamp installations supplied at over 250 V shall be provided with warning notices giving the voltage rating. All live parts of such installations shall be protected against an inadvertent touch during maintenance.

6.5.14 The lighting fixture design shall provide the relevant removal of heat from cases which is caused by the heating from lamps, ballast resistors, capacitors, etc. The temperature of lighting fixture surfaces which may be touched in maintenance shall not exceed 60 °C.

6.5.15 The excess of temperature for terminals used for the connection of supply cables over the ambient temperature shall not exceed 40 °C.

6.5.16 The insulation class of wires used for internal connections shall be consistent with the maximum temperature inside lighting fixture cases.

6.5.17 Tube retainers (lampholders) used in lighting fixtures shall be of the standard type in accordance with [Table 6.5.17](#).

Table 6.5.17

Tube retainer type	Permissible lamp characteristics	
	Voltage, V	Output, W / Current, A
With screwed lamp-base:		
E40	250	3000/16
E27	250	200/4
E14	250	15/2
E10	24	
With bayonet lamp- base:		
B22	250	200/4
B15d	250	15/2
5s	55	15/2
For bar luminescent lamps:		
G13	250	80/
G5	250	13/
For linear halogen and metal-haloid lamps:		
R7s	250	1500/
Fa4	250	2000/

6.5.18 Tube retainers for lamps with the E40 lamp-base shall be fitted with devices to locate (secure) the lamp in a holder.

6.6 SOCKET OUTLETS

6.6.1 Socket outlets for portable lighting fixtures shall be installed at least:

- .1** on deck near windlass and mooring winch control stations;
- .2** in rooms for a gyrocompass and other navigational equipment (if any);
- .3** in the radio equipment converter room;
- .4** in the steering gear and thruster compartments (if any);
- .5** in the emergency generator set compartments;
- .6** in the machinery rooms;
- .7** behind the main switchboard;
- .8** in special electrical rooms;
- .9** at bridge and reserve control stations;
- .10** in the radioroom (if any);
- .11** in the vicinity of recesses for a log, echo-sounder, other devices associated with measurements of environmental parameters;
- .12** in spaces where centralized ventilation and air-conditioning installations are located.

6.6.2 Socket outlets for portable equipment which are fed with different voltages shall be so designed as to prevent the insertion of a plug intended for one voltage into a socket for another one.

6.6.3 Socket outlets for portable lighting installed on the open decks shall be mounted with their face looking downward.

6.6.4 Socket outlets shall not be fitted in machinery spaces below plating, in enclosed fuel and oil separator rooms or in locations where explosion-proof type equipment is required.

6.7 ILLUMINATION

6.7.1 The illumination of particular spaces and areas shall be not less than that required by national sanitary standards and at least not less than specified in [Table 6.7.1](#).

The general lighting standards given in [Table 6.7.1](#) refer to the level of 800 mm above the deck (floor) of a space, while the standards of the general plus local lighting, to the level of working surfaces.

The general lighting shall be measured at the level of 1 m above the deck (floor), and the local lighting – directly above the working surface.

Table 6.7.1

Spaces and areas	General (average) illumination (E_{av}), lux	Minimum illumination, lux	Maximum illumination, lux
Exterior spaces (main lighting)	50	20	100
Interior rooms, corridors, accommodation spaces (main lighting)	100	40	200
Stairways	150	60	300
Process spaces attended periodically	150	60	300
Process spaces attended frequently	300	150	450
Drilling site	300	150	450
Control stations, laboratories	500	250	750
Machinery rooms, pump rooms	200	80	400
Auxiliary machinery rooms	200	80	400
Workshops	300	120	600
Switchboard rooms	300	150	450
Service rooms (offices)	500	250	750
Laundries, galleys, mess rooms	300	120	600
Sick-bay, hospital	300	120	360
Local lighting in sick-bay	1000	500	1500
Rooms for radio equipment	500	250	750
Emergency sick-bay (if provided)	300	120	360

Notes: 1. Number of gauge points required for illumination gauging is chosen from the below table and depends on the space index calculated by the formula:

$$K = (ab)/h(a + b)$$

where K = index;
 a and b = lateral lengths of a space;
 h = level of a lighting fixture above working area.

Space index K	Number of gauge points
Less than 1	4
From 1 up to 2	9
From 2 up to 3	16
3 and more	25

2. Design of initial illumination levels shall provide for natural deterioration of illumination due to lamps aging and lighting fixtures clogging.

6.8 SEARCHLIGHTS AND ARC LAMPS

6.8.1 All parts of searchlights or arc lamps to be maintained and adjusted in operation shall be so designed as to prevent the electric shock risk for an operator.

6.8.2 Switches intended for searchlights or arc lamps shall be multipolar.

6.8.3 Where series resistors are used with arc lamps, switches shall disconnect both the lamp and its series resistor from the network.

7 INTERNAL COMMUNICATION AND ALARMS

7.1 ELECTRIC ENGINE TELEGRAPHS OF SELF-PROPELLED MODU

7.1.1 In addition to the requirements of this Chapter, engine telegraphs shall meet the requirements of Part VII "Machinery Installations and Machinery" of the MODU Rules.

7.1.2 Engine telegraphs shall have an illumination-adjusted dial, to be provided with visual indication of voltage presence and audible warning of voltage loss in the power circuit.

7.1.3 Engine telegraphs shall be fed from the main switchboard or from the navigation equipment switchboard.

Where the MODU is provided with an integrated bridge control console, the engine telegraph may be fed from this control console.

7.1.4 The engine telegraph shall be so installed at the bridge control station that when an order to move the unit is given out, the telegraph operating handle is shifted in the same direction as the MODU. The vertical position of the handle shall correspond to the "Stop" order.

7.1.5 Where engine telegraphs and devices for remote control of the main engines and controllable pitch propellers are installed on sloping desks of control panels, the handle in the "Stop" position shall be perpendicular to the panel surface and be precisely fixed in this position.

7.1.6 Where two or more engine telegraphs are located in the close proximity to one another (on one deck), they shall ensure the transmission of orders from any telegraph and the reception of order by all of them simultaneously, without additional changing-over.

Change-over to the telegraphs located on another deck or in another part of the MODU shall be effected by means of switches fitted on the navigating bridge (at the bridge control station).

7.1.7 Each engine telegraph shall be provided with an audible signal arrangement that ensures the actuation of an audible alarm by the transmitting and receiving device when an order is given and responded. The audible signal arrangement shall continue functioning until the right response to the given order is received (refer also to Part VII "Machinery Installations and Machinery" of the MODU Rules).

7.2 INTERNAL SERVICE COMMUNICATION

7.2.1 Provision shall be made for independent two-way telephone communication between the bridge, reserve and local control stations of the machinery installation, and also between the bridge control station and the radioroom (if it is outside the bridge control station).

If the MODU main control station of the machinery installation is of the enclosed or outdoor type, independent two-way voice communication between the main machinery control room and bridge and reserve control stations shall be also provided.

For this purpose, use may be made of either independent two-way telephone communication or two-way telephone communication between the bridge and main machinery control room with telephones connected in parallel and installed at the local control stations.

7.2.2 In addition to the communication facilities specified in [7.2.1](#), provision shall be made for a separate system of independent telephone communication between the bridge and reserve control stations and:

- the stations in the main service spaces;
- the stations on the forecastle and poop;
- the watch station on the mast (if any);
- the stations in the steering gear compartment, the spaces for thrusters, an emergency switchboard, essential navigation equipment, a fire smothering station;
- engineers' accommodations;
- other spaces in which arrangements ensuring MODU operation safety are located.

Provision shall be made for telephone communication between the main control station, the local control station of the main machinery and engineers' accommodations. For this purpose, a two-way loudspeaker device may be used instead of telephones.

When independent two-way voice communication between the bridge and reserve control stations and the above spaces is provided, additional communication facilities need not be installed.

7.2.3 Internal service communication systems shall ensure the possibility to call a subscriber and good audibility under conditions of a specific noise near communication facilities locations. When the service telephone sets are installed in the space of high noise intensity, measures shall be taken for noise absorption or additional handsets shall be provided.

7.2.4 For communication facilities specified in [7.2.1](#) and [7.2.2](#) use shall be made of voice-powered telephones or provision shall be made for power supply from the main source of electrical power and accumulator battery actuated automatically in case of failure of the main source of electrical power, i.e. from an uninterruptible power supply system.

7.2.5 The damage to or disconnection of one telephone set shall not interfere with operability of other sets.

7.2.6 The telephone sets mentioned in [7.2.1](#) for two-way voice communication shall be fitted with audible and visual alarms to indicate the call both at the main machinery control room and in the engine room.

7.2.7 The two-way loudspeaker device may be independent or combined with public address system.

7.3 GENERAL ALARM SYSTEM

7.3.1 MODU shall be provided with a general alarm system which ensures good audibility of signals in all the spaces and locations where people may be present. A visual alarm, e.g. a rotating flashing lamp shall be fitted in the spaces of the high noise level in addition to an audible alarm.

7.3.2 Sound and visual devices of the general alarm system shall be installed in the following places:

- .1** in machinery spaces;
- .2** in service and public spaces;
- .3** in corridors of accommodation, service and public spaces;
- .4** on open decks;
- .5** in working spaces and areas.

7.3.3 The general alarm system shall be supplied from the unit's mains, and also from busbars of the emergency switchboard according to the requirements of [9.3.1.7](#) and [9.3.6.3](#), or from uninterruptible power supply system of essential equipment.

The general alarm system may be supplied from the mains and from a separate accumulator battery if provision is made for an automatic changeover of general alarm circuits to this battery. In this case, no supply from the emergency and transitional sources of electrical power is needed.

7.3.4 The general alarm system shall be continuously supplied whether the accumulator battery is being charged or discharged.

7.3.5 Where a separate accumulator battery is used for supply of the general alarm system, it may also feed other internal communication and signaling facilities if the battery capacity is sufficient for simultaneous supply of all consumers for at least 3 h, and also if these facilities are so designed that a damage to one circuit will not interfere with operation of other circuits provided no longer supply time is required for those facilities.

7.3.6 In circuits supplying the general alarm system, the protection against a short circuit only shall be provided. Protective devices shall be fitted in both conductors of the feeder, and also in circuits of each sound device.

Protection of several sound devices with one common protective device is permitted if in spaces where they are installed, good audibility of other sound devices provided with independent protection is ensured.

7.3.7 General alarm sound devices shall be so located that a signal is clearly heard against the noise in the given space. The sound devices installed in spaces with the high intensity of noise shall be additionally fitted with a visual alarm.

The tonality of general alarm devices shall be distinct from that of devices of other alarm kinds.

Audible alarms (excepting bells) shall have a signal frequency within 200 to 2500 Hz. Means may be provided for regulating the audible signals frequency within the above limits.

7.3.8 The general alarm system shall be actuated by means of a double-pole self-restoring switch from the bridge control station, control station for drilling operations, navigation bridge (if any), fire control station (if any), and also from the space intended for watchkeeping in the absence of personnel at the bridge control station.

A pilot lamp to indicate actuation of the general alarm shall be fitted in the switch circuit at control stations.

The switches shall be provided with inscriptions indicating their purpose.

7.3.9 No switching devices shall be incorporated into the circuits of the general alarm system other than the switch specified in [7.3.8](#). In order to prevent unauthorized disconnection of the general alarm system, its switchboard shall be fitted with the interlocking device of a power supply switch in the "ON" position or with other devices preventing access to it for unauthorized persons.

It is permitted to use intermediate contactors controlled by the switch, but not more than one contactor in each section.

7.3.10 Sound devices, switches and distribution switchboards of the general alarm system shall be provided with readily visible distinctive symbols.

7.3.11 The network of general alarm sound devices shall consist of at least two sections controlled with one switch, and the sound devices shall be so positioned that in spaces of large area (machinery spaces, boiler rooms, process spaces and others) they are connected to different sections.

7.4 FIRE DETECTION AND FIRE ALARM SYSTEM

7.4.1 In addition to the requirements of this Chapter, fire detection and fire alarm systems shall meet the requirements of Section 4, Part VI "Fire Protection" of the MODU Rules.

7.4.2 Application of fire detectors located in spaces of potential explosive vapours accumulation or being in the air flow from these spaces is regulated by [2.9](#).

7.4.3 For power supply of fire detection and fire alarm system, provision shall be made for at least two sources of electrical power one of which shall be an emergency one. The power supply shall be effected by separate feeders intended for that purpose only. In case of failure of the main source of electrical power, provision shall be made for an automatic changeover of supply to the emergency source with actuation of an audible and visual signal. Where an accumulator battery is the main source of power supply, two separate accumulator batteries (main and standby) shall be provided, with the capacity of either being sufficient for operation of the fire detection and fire alarm system for at least 3 days without recharge.

7.4.4 The fire detection and fire alarm system operating on the principle of sampling the air from protected spaces to convey it to an indicating unit shall be fed along with its fans by separate feeders from the main and emergency sources or from another independent source of electrical power.

7.4.5 The central indicating unit of fire detection and fire alarm system shall be designed in such a manner that:

.1 any signal or damage to one circuit does not affect normal functioning of other circuits;

.2 a fire detection signal dominates over other signals coming to the indicating unit and allows to determine the location of the space wherefrom this signal has come;

.3 contact-type fire detector circuits operate for opening; it is permitted to use detectors operating for closing if their contacts are sealed and their circuit is monitored for an open-circuit and ironwork fault;

.4 provision is made for monitoring its operation;

.5 provision is made for the disconnection of separate sections or detectors. In this case, a visual alarm shall be provided to indicate that the section or detector is turned off.

7.4.6 The indicating unit of fire detection and fire alarm system shall produce, as a minimum, the information specified in [Table 7.4.6](#).

Table 7.4.6

Nos	Operation mode	System with temperature detector	System with air sampling
1	In operation	Light	Light
2	Power supply from emergency source	Light & Sound	Light & Sound
3	Fire	Sound, light and location	Sound, light and location
4	Detector malfunction	Light & Sound	–
5	Sampling fan malfunction		Light & Sound

A visual signal of fire detection shall be executed in such a manner that it consists of two indicators (two lamps or a double filament), or a special device shall be provided to check the proper condition of signaling lamps. The colour of the visual signal shall comply with the requirements of [4.5.5](#).

Visual signals shall be individual for each kind of information.

The signals intended for determination of the location of the space or area, wherefrom a pulse has come, may be common with the signal of fire detection or damage.

Visual signals shall function from the moment a pulse is received till the moment the cause of their actuation has been eliminated with the signal specified in [item 1 of Table 7.4.6](#) continuously operating irrespective of the power supply source type.

7.4.7 If the fire detection signal has not received (acknowledged) in the indicating unit within two minutes, fire alarm shall be automatically actuated in machinery, accommodation and other spaces where personnel may be present.

7.4.8 Fire detection and fire alarm system with a zone address identification capability shall be so designed that:

- .1 a loop cannot be damaged at more than one point by fire;
- .2 means are provided to ensure that any damage (e.g. power break, short circuit, earthing) to the loop will not disable its remaining part;
- .3 all arrangements are made to enable the initial configuration of the system to be restored in the event of failure of its mechanical, electric and electronic elements;
- .4 the actuation of the first fire detection and fire alarm system does not prevent any other detector to initiate subsequent fire alarms.

7.4.9 Two indicating units, as a minimum, shall be provided in the fire detection and fire alarm system. The central indicating unit shall be located at the main control station and the back-up one at the reserve control station.

7.4.10 Fire detectors and manual fire alarms shall be fitted in the spaces and locations in which a fire may occur. Provision shall be made for detectors and/or manual fire alarms in all the spaces for process equipment, in machinery spaces, control stations, switchboard spaces, corridors, cabins, store rooms and other spaces of an accommodation module. Manual fire alarms shall be fitted in places where personnel is usually present. The drawings of detectors and manual fire alarms layout are subject to the Register consideration.

7.4.11 If the automatic stop of process or other essential equipment is made, when fire detection and fire alarm system is actuated, then, in this case, the system design shall ensure the improved reliability of alarm actuation through redundancy and the logical processing of detector signals. The above requirement may be effected, for instance, by fitting in one space at least three detectors connected to different sections (circuits) using majority voting two in every three.

7.4.12 When fire detection and fire alarm system is actuated, its central indicating unit shall put out to external devices, as a minimum, the following control signals:

- into the system of the emergency stop of process machinery and arrangements for the activation of one of the levels depending on the ignition address;
- into the system of the emergency stop of the fans of appropriate spaces, and for closing of fire doors and dampers;
- into devices for the emergency start of fire pumps;
- into the MODU general alarm system.

7.5 WARNING ALARM OF FIRE SMOTHERING SYSTEM RELEASE

7.5.1 In addition to the requirements of this Section, the warning alarm system shall meet the requirements of Part VI "Fire Protection" of the MODU Rules.

7.5.2 The warning alarm system shall be fed from the unit's mains and an accumulator battery having a capacity sufficient for system operation during 30 min.

Provision shall be made for a device to automatic change-over power supply for the warning alarm system to the accumulator battery in case of the unit's mains voltage loss.

7.6 INDICATION OF WATERTIGHT AND FIRE DOORS CLOSURE

7.6.1 The visual alarm (indication) to show whether the watertight doors and companion hatches are open or closed as required by 8.3.3 and 8.4, Part III "Equipment, Arrangements and Outfit of MODU" of the MODU Rules shall be power supplied from the unit mains and an independent power source as specified in [7.3.3](#).

7.6.2 The visual alarm (indication) to show whether the fireproof doors are open or closed as required by 2.1.5, Part VI "Fire Protection" of the MODU Rules shall be power supplied from the unit mains and an independent power source as specified in [7.4.3](#).

7.7 MACHINERY INSTALLATION ALARM SYSTEM IN MODU ENGINEERS' ACCOMMODATIONS

7.7.1 Provision shall be made for the generalized alarm system of a machinery installation in engineers' accommodations in accordance with the requirements of 2.4.1.1, Part XIV "Automation" of the MODU Rules.

7.7.2 In addition, provision shall be made in the same accommodations for an audible and visual alarm of the engineer's call in emergency, manually-actuated from the main machinery control room of a machinery installation or from a machinery space.

7.7.3 Power supply of the above alarm systems shall be carried out from an uninterruptible power supply source as specified in [4.2](#).

7.8 NAVIGATION LIGHTS

7.8.1 A special switchboard shall be provided to supply permanently mounted navigation lights listed in Section 2, Part XVI "Signal Means" of the MODU Rules.

7.8.2 The navigation lights switchboard shall be supplied by two feeders:

- .1** one feeder from the main switchboard through the emergency switchboard;
- .2** the second feeder from the nearest group switchboard which is not supplied from the emergency switchboard;
- .3** from an uninterruptible power supply system as specified in [4.2](#).

7.8.3 Navigation lights shall be connected to a supply circuit with a flexible cable with a plug connector.

7.8.4 The supply circuits of navigation lights shall be of a two-wire system with a double-pole switch for each circuit to be fitted in the navigation lights switchboard.

7.8.5 Each navigation lights supply circuit shall be provided with protection in both wires and with indication of navigation light switching.

The visual indicator of the intact condition of a signal lamp shall be so designed and installed that its failure does not cause the navigation light turn-off.

The voltage drop at the switchboard supplying navigation lights including the indicating system of lights operation, shall not exceed 5 % at the rated voltage up to 30 V and 3 % at the rated voltage over 30 V.

7.8.6 Irrespective of the navigation light switching indication specified in [7.8.5](#), provision shall be made for visual and audible alarms operating automatically in case of failure of any navigation light with the switch in the "ON" position.

The alarm shall be supplied from a source or feeder other than that used for power supply to navigation light switchboard, or from an accumulator battery.

7.8.7 The design of navigation lights shall comply with the requirements set out in Section 3, Part XVI "Signal Means" of the MODU Rules.

7.9 EXPLOSIVE GAS DETECTION AND ALARM SYSTEM

7.9.1 A fixed explosive gas detection and alarm system shall be provided at the unit's bridge or main control station to monitor every area and all enclosed spaces of the unit in which a dangerous accumulation of explosive gas mixture may be expected to occur. The back-up panel of the fixed explosive gas detection and alarm system shall be fitted at the unit's reserve (emergency) control station. The system shall be capable of indicating on call the value of explosive gas mixture concentration.

7.9.2 Sensors (gas analyzers) of explosive gases concentration shall be installed in at least the following spaces and areas:

in hazardous spaces and areas of zone 1;

in all the inlets of ventilating ducts directing air into non-hazardous zones;

in the spaces and areas specified in Part VI "Fire Protection" of the MODU Rules.

Provision shall be made for an opportunity to disconnect any individual gas analyzer or section from the main control station. In doing so, a visual alarm indicating the disconnected gas analyzer or section shall be activated at the central station.

7.9.3 The alarm system shall give a visual and audible alarm in the bridge control station when the following levels of explosive gas concentrations are detected in the protected spaces:

maximum concentration of 25 and 60 % of the lower explosive limit (LEL), as specified in Part VI "Fire Protection" of the MODU Rules;

low level alarm set at 10 ppm and high level alarm set not higher than 300 ppm for hydrogen sulphide.

The hydrogen sulphide high level alarm shall activate an evacuation alarm.

If the signal of explosive gas (hydrogen sulphide) concentration has not received (acknowledged) in the indicating unit within 2 min, the signal "GAS" shall be automatically put out to the general alarm system.

7.9.4 The automatic system for the shutdown of non-explosion proof type electrical equipment shall be activated when:

explosive gases concentration specified in [7.9.3](#) reaches 60 % of LEL; or

explosive gases concentration is detected in inlets of the air ducts directing air into non-hazardous zones.

The logic of automatic system for the shutdown of non-explosion proof type of the electrical equipment shall be consistent with the dynamic positioning system commands in case the latter is used to maintain operational control over the integrity of the well.

7.9.5 Power supply of an explosive gas detection and alarm system shall be effected from the main and emergency sources of electrical power, or from the uninterrupted power supply system as specified in [4.2](#).

7.9.6 A gas alarm system shall be capable of selftest. At least on damages like the power supply loss, a power break or a short circuit in sensors, or on damages to a sample lines and ventilation system, an alarm shall be given.

7.9.7 Provision shall be made for the possible check of proper gas analyzers functioning, for instance, by use of calibration aerosols having the fixed gas concentration.

7.9.8 When a gas alarm system is actuated, the signal "GAS" shall be put out to the unit's general alarm system.

7.10 LIGHTING AND ILLUMINATION SIGNAL MEANS FOR HELIDECKS

7.10.1 General.

7.10.1.1 Lighting and illumination signal means for helidecks shall comply with the applicable requirements stated in [6.2](#).

7.10.1.2 The lighting and illumination signal means for helidecks shall, at least, provide for the following:

indication of the perimeter (boundaries) of helidecks;

illumination of the landing area;

indication of the elevated structures within the landing area.

7.10.1.3 Lights used for this purpose shall have protection degree not lower than IP56 and function reliably under environmental effects specified in Section 2, Part XI "Electrical Equipment" of the RS Rules/C.

7.10.1.4 All lighting and illumination signal means, as well as other electrical equipment within the helicopter refuelling stations and hangars shall be of explosion-proof type and have explosion protection degree corresponding to at least temperature class T3 and sub-group IIA.

7.10.1.5 In respect to lighting characteristics, selection of light types and design shall meet the requirements of 3.1, Part XVI "Signal Means" of the MODU Rules and the requirements of ICAO (International Civil Aviation Organization) which shall be confirmed by the appropriate conclusion or by a Certificate of the Civil Aviation competent body.

7.10.1.6 The lighting and illuminating signal means specified in this Chapter shall be supplied by a separate switchboard fed from the main and emergency power sources with an automatic change-over in the event of loss of power.

7.10.2 Perimeter lighting.

7.10.2.1 All-round lights chained up along the boundary of the helideck site shall be provided to indicate the perimeter (boundaries) thereof (at least 8 lights).

7.10.2.2 The distance between adjacent lights shall not exceed 3 m. The lights to indicate the perimeter shall be green.

7.10.2.3 The lights shall be divided into two independent circuits and supplied in such a manner that when the power to any one circuit fails, 50 % of lights to indicate the perimeter remain functioning.

7.10.2.4 After installation, the globes of the lights shall not rise to a height of more than 150 mm above the helideck level.

7.10.3 Illumination of the landing area.

7.10.3.1 The landing area and wind direction indicator shall be properly illuminated. For this purpose floodlights may be used.

7.10.3.2 Appropriate measures shall be taken when the illumination signal means are being installed to avoid glare to pilots during take-off, landing and manoeuvring.

7.10.4 Obstruction/warning lights.

7.10.4.1 To provide safety of flight, all considerably elevated structures and items such as superstructure components, drill stem and production strings, etc. shall be marked by special obstruction/ warning red lights.

7.10.4.2 Lights shall be divided into two independent circuits and supplied in such a manner that when power supply to one of the circuit fails, the basic part of the obstruction/warning lights remains functioning.

7.11 DRILLING MUD SYSTEM LEVEL ALARMS

7.11.1 A suitable visual and audible alarm to indicate significant increase or decrease in the level of the contents of the mud pit shall be provided at the control station for drilling operations.

8 ELECTRIC PROTECTION SYSTEM

8.1 GENERAL

8.1.1 Every separate electrical circuit shall be protected against a short circuit and an overload unless another way of protection or an alarm system is specified for the separate circuits (as for instance, for steering gear and fire pump electrical circuits).

8.1.2 Outgoing circuits of switchboards shall be protected against short circuits and overloads by means of devices installed at the inception of each circuit.

No overload protection is required for the switchboard supply circuit if the current consumers supplied from this switchboard have individual protective devices against overloads, and the cable of the switchboard supply circuit is selected on the basis of the maximum total current for all consumers of this switchboard.

8.1.3 Protective devices shall be so adapted to the characteristics of the equipment under protection that they activate under inadmissible overloads. The rated settings of overload protective devices for each circuit under protection shall be clearly shown on protection instruments.

8.1.4 The electric protection system shall be discriminative with regard to both the overload currents and the short-circuit currents to be expected. Such protection system shall be designed so that damages to non-essential consumers and their supply circuits could not adversely affect the reliable functioning of the MODU generating plant and the power supply of essential services.

Short-circuit and overload protective devices shall not actuate at starting currents of the electrical equipment under protection.

8.1.5 Overload protection shall be provided in:

- .1** not less than one phase for a one-phase alternating current system or in a positive pole for a two-wire direct current system;
- .2** not less than two phases for an insulated three-wire three-phase current system;
- .3** all phases for a three-phase four-wire system.

8.1.6 Short-circuit protection shall be fitted in each insulated pole of a direct-current system, and also in each phase of an alternating current system.

Short-circuit current protective devices shall be set to operate at not less than 200 % of the rated current of the electrical equipment under protection. The protective devices may be actuated without or with a time delay necessary for proper discrimination.

8.1.7 Where cables of reduced cross-sectional area are used in some lengths of a supply circuit, additional protection shall be provided for each of such cables unless the preceding protective device is capable of protecting the cable of reduced cross-sectional area.

8.1.8 Protective devices, which exclude the possibility of immediate repeated switching-in after the actuation of protection, shall not be used in supply circuits of the emergency switchboard, as well as in supply circuits of the emergency consumers.

8.1.9 Additional requirements for protective devices in networks with a voltage in excess of 1000 V are given in [Section 18](#).

8.2 PROTECTION OF GENERATORS

8.2.1 Generators not intended for operation in parallel shall be provided with overload and short-circuit protective devices. Generators intended for parallel operation shall be provided with at least the following protective devices:

- .1 against overloads;
- .2 against short circuits;
- .3 against reverse current or reverse power;
- .4 against undervoltage.

8.2.2 The generators overload protection system shall comply with their overload characteristics and meet the following requirements:

.1 only a visual and audible alarm system operating with a time delay within the range of 0 to 15 min shall be provided for overloads of up to 10 %. The time delay over 15 min is permitted if it is required due to operational conditions and provided by the generator design;

.2 a circuit breaker shall disconnect a generator with the time delay corresponding to 2 min at the 50 % overload (i.e. at lesser overloads, the time delay over 2 min shall be provided) for overloads within the range of 10 to 50 %. The overload over 50 % of the rated one and the 2 min time delay may be exceeded if it is required under operational condition of a generating plant and provided by the generator design;

.3 for overloads over 50 % of the rated one, the disconnection of a generator shall occur with the time delay ensuring the proper selectivity for which purpose provision shall be made for the relevant time delays in circuit breakers of generators.

8.2.3 Provision shall be made for devices which automatically and selectively disconnect non-essential consumers at the generators overload. The consumers disconnection may be performed in one or several steps depending on the generator overload capacity.

8.2.4 Protection of generators intended for operation in parallel against a reverse current or reverse power shall be selected to suit characteristics of generator prime mover. The respective protection settings shall comply with those given in [Table 8.2.4](#).

Table 8.2.4

Current types	Limits of reverse-current or reverse-power protection settings related to generator prime mover	
	Turbine	Internal combustion engine
Alternating	2 – 6 % of rated output of generator, kW	8 – 15 % of rated output of generator, kW
Direct	2 – 15 % of rated current, A	2– 15 % of rated current, A

Reverse-current protection for direct-current generators shall be installed in the pole opposite to that in which an equalizer is connected. Reverse- power or reverse-current protection still be capable of operation when the voltage applied is reduced by 50 % although the values of reverse current or reverse power may be changed.

8.2.5 Undervoltage protection shall ensure the possibility of a reliable connection of generators to busbars at a voltage of 85 % and over the rated one and shall exclude the possibility of the generator-to- busbars connection at a voltage less than 35 % of the rated one, and shall also disconnect the generators in case of reduction of voltage across its terminals in the range of 70 to 35 % of the rated value.

Undervoltage protection shall operate with a time delay for the disconnection of generators from busbars in case of voltage reduction and shall instantaneously actuate at the attempt to make connection to the generator busbars before the undervoltage specified above is reached.

8.2.6 Generators with the ratings of 1500 kVA and above shall be equipped with protective device or protective system, which shall open the circuit-breaker and shut down the

generator in the event of a short circuit in the generator or in the supplying cable between the generator and its circuit-breaker. This requirement shall not apply to emergency generators.

8.2.7 Where a turbine-driven direct-current generator is intended for operation in parallel, provision shall be made for a device to trip the circuit breaker of the generator when a turbine safety regulator is actuated.

8.2.8 The current settings of protective devices with a time delay shall be selected in such a way that in any case the reliable interruption of a short-circuit current is ensured after the prescribed time delay.

8.2.9 Safety fuses as a protective device for semiconductor elements may be used in generator excitation systems.

8.3 PROTECTION OF ELECTRIC MOTORS

8.3.1 Outgoing feeders from switchboards supplying electric motors rated over 0,5 kW shall be provided with short-circuit current and overload protective devices, and also with a no-voltage protection device unless the repeated automatic start of an electric motor is needed.

Overload and no-voltage protective devices may be fitted in motor starting apparatus.

8.3.2 Overload protective devices for continuously running motors shall disconnect the motor under protection when the loading is in the range of 105 to 125 % of the rated current.

8.3.3 In supply circuits of electrically-driven fire pumps, the overload protective devices operating on the principle of electrothermal or temperature relays shall not be used. In this case, provision shall be made for a visual and audible alarm instead of the overload protective devices.

8.4 PROTECTION OF ELECTRIC DRIVES OF MODU STEERING GEAR

8.4.1 Only short-circuit current protection shall be provided for electric motors and control systems of electric or electrohydraulic steering gear.

A visual and audible alarm of the motor overload and any phase failure shall be provided.

8.4.2 Circuit breakers protecting direct-current (DC) motors against short-circuit currents shall have trip settings without a time delay at currents not lower than 300 % and not higher than 400 % of the rated current of the motor under protection, while those protecting alternating-current (AC) motors shall have trip settings without a time delay at currents over 125 % of the peak starting current of the motor under protection.

If fuses are used as protective devices, the rated current for the fuse shall be one grade of rating higher than it follows from the conditions specified for starting currents of electric motors.

8.4.3 Electric motors for the drives of MODU active steering means (thrusters) shall be provided with overload and short-circuit protective devices. The overload protective devices of the above drives shall be fitted with a visual and audible alarm of overloading and to disconnect the electric motor within the load range specified in [8.3.2](#) with the proper time delay.

Short-circuit protection shall meet the requirements of [8.4.2](#).

8.5 PROTECTION OF TRANSFORMERS

8.5.1 Short-circuit and overload protective devices shall be installed on the supply feeders of transformer primaries. Transformers rated up to 6,3 kVA may be protected by fuses only.

8.5.2 Where transformers are intended for operation in parallel, provision shall be made for circuit breakers to disconnect their primaries and secondaries, but not necessarily at the same time.

If such transformers are fed from different main switchboard sections which may be isolated in service, provision shall be made for an interlock to prevent their operation in parallel in case of main switchboard sections isolation.

8.6 PROTECTION OF ACCUMULATOR BATTERIES

8.6.1 Short-circuit current protective devices shall be provided for accumulator batteries other than those which are intended to start internal combustion engines.

8.6.2 Each battery charging system shall be provided with protection against battery discharge due to a drop or loss of the charger output voltage.

8.6.3 For accumulator batteries intended for starting internal combustion engines, it is advised to fit disconnectors at the start of a circuit on the accumulator side to disconnect the batteries from consumers (the disconnectors may be fitted in one pole).

8.7 PROTECTION OF MEASURING INSTRUMENTS, AND CONTROL AND MONITORING DEVICES

8.7.1 Pilot lamps, as well as measuring and recording instruments shall be provided with short-circuit protection or short-circuit current limiting devices.

Pilot lamps may have no short-circuit protection of their own, nor short-circuit current limiting devices, provided that all the conditions specified below are met:

- .1** the lamps are enclosed together with the device;
- .2** the lamps are supplied from circuits inside the device enclosure;
- .3** the protection of the device circuit is rated for current not exceeding 25 A;
- .4** a fault in the lamp circuit cannot result in an interruption in the operation of an essential service.

Short-circuit protective devices or short-circuit current limiting devices shall be located as close as practicable to the terminals on the supply side.

8.7.2 Radio interference suppression capacitors in the circuits of main and emergency switchboards, generators, and essential electrical installations shall be protected against short-circuit currents.

8.7.3 The voltage coils of apparatus and devices for control and protection shall be protected against short-circuit current, but they may have no protection of their own, provided that the conditions specified below are met:

- .1** the coils are enclosed with the device, are under overall protection and belong to the control system of one device;
- .2** the coils are fed from the circuit of the device whose protection is rated for current not exceeding 25 A.

8.7.4 No overload protection and alarm is needed for voltage measuring transformers and control circuit transformers.

The switching-over of instrument current transformers shall be so arranged as to prevent the possibility of their secondaries being open-circuited.

8.8 PROTECTION OF POWER SEMICONDUCTOR UNITS

8.8.1 Provision shall be made for protecting power semiconductor units from internal and external overvoltage.

8.8.2 Semiconductor element units shall be protected against a short-circuit. The protection of separate diodes and thyristors shall be isolated from the protective load circuit.

8.8.3 Where only one consumer is available, a common protection for a load and semiconductor element units is permitted.

8.9 RESIDUAL CURRENT DEVICES

8.9.1 To protect personnel against electrical shock and to protect some types of electrical equipment against single-phase earth fault residual-current devices shall be used.

8.9.2 Residual-current devices shall be fitted in the supply circuits of socket outlets intended to feed the portable equipment and in the supply circuits of cabin socket outlets as well as the socket outlets in public and other spaces with a voltage exceeding standard safety value (50 V).

8.9.3 Residual-current devices shall be set to operate at the zero sequence current within the following limits:

30 mA – for consumers with double or reinforced insulation;

10 mA – for consumers with standard insulation.

8.9.4 For essential electrical equipment installation of the residual-current devices are not permitted.

9 EMERGENCY ELECTRICAL INSTALLATIONS

9.1 GENERAL

9.1.1 Every MODU shall be provided with the self-contained emergency and emergency transitional sources of electrical power. As the emergency source, a diesel-generator shall be used while as the emergency transitional source, the system of accumulator batteries with an automatic charging unit supplied from the main switchboard busbars.

9.1.2 Where the main source of electrical power along with its distribution switchboard and control systems is fully independent of the distribution switchboard and control systems in other spaces so that a fire or another accident in one of those spaces will not disrupt normal supply of the unit from other sources, then the separate emergency source of electrical power may not be installed provided that:

.1 there are at least two generators, meeting the requirements of this Part, in two or more spaces;

.2 existing generators are provided with automatic start systems which ensure the start of a standby generator and load take-over within 45 s;

.3 the location of each space containing generator sets meets the requirements of [9.2.1 to 9.2.3](#).

9.1.3 The capacity of emergency source of electrical power shall be sufficient to supply all those services whose simultaneous operation is essential for MODU safety in an emergency.

9.1.4 Facilities shall be provided for testing the complete emergency installation including automatic start devices of a diesel-generator.

9.1.5 An indicator activated at the discharge of any accumulator battery which is a temporary emergency or a standby source of power shall be fitted at the main machinery control room of the machinery installation or on the main switchboard.

9.1.6 Emergency sources of electrical power shall be provided with short-circuit protection only. A visual and audible alarm of a generator overload shall be provided for the emergency diesel-generator at the main machinery control room.

9.2 SPACES OF EMERGENCY SOURCES OF ELECTRICAL POWER

9.2.1 The spaces of emergency sources of electrical power and of their transformers (if any), of transitional emergency sources of electrical power, emergency switchboard and distribution board of emergency lighting shall be located above the uppermost continuous deck, astern from collision bulkhead (if any) outside machinery casings and as far as possible from hazardous zones and shall be easily accessible from the open deck. The above spaces on MODU shall be also located at a height of at least 300 mm above the damage waterline specified in Part V "Subdivision" of the MODU Rules.

9.2.2 The location of emergency sources of electrical power and of pertinent transformers, if any, of transitional sources of electrical power, an emergency switchboard and an emergency lighting switchboard in relation to the main sources of electrical power, their transformers and the main switchboard shall be such that a fire or another accident in the space of the main source of electrical power, of pertinent transformers and the main switchboard, and also in any machinery space of Category A will not cause damages to a supply system, and to the control and distribution of electrical power from the emergency source.

9.2.3 Spaces containing emergency sources of electrical power, pertinent transformers, transitional sources of electrical power, an emergency switchboard and emergency lighting switchboard shall not be adjacent to machinery and boiler spaces and to spaces of the main source of electrical power, pertinent transformers, and the main switchboard.

9.2.4 An emergency switchboard shall be installed as close as possible to the emergency source of electrical power, i.e. in the same space as the diesel-generator excepting the case where such location affects the switchboard operation.

All starting and charging devices as well as starter accumulator batteries for an emergency set with due regard for fulfilment of the requirements given in [1.3.2](#), shall be located in the same space.

9.2.5 The space containing an emergency generator set shall be provided with heating appliances to ensure the temperature sufficient for trouble-free starting of the emergency set, and with ventilation for adequate air supply to operate the diesel-generator under the full load with the space closed.

9.3 EMERGENCY SOURCES OF ELECTRICAL POWER

9.3.1 The MODU emergency sources of electrical power shall provide a supply for the following services for a period of 18 h:

- .1** emergency lighting for:
 - all corridors, stairways and exits from service spaces as well as personnel lift cars and personnel lift trunks;
 - machinery spaces and generator sets spaces;
 - all local control stations, as well as the main and emergency switchboards;
 - emergency diesel-generator spaces;
 - the bridge and reserve control stations and spaces associated with control of industrial process and machinery essential for maintaining this process, as well as the spaces containing devices for the emergency disconnection of electrical equipment;
 - the wheelhouse and radioroom (if any);
 - stowage positions for emergency and fireman's outfit, and positions where manual fire alarms are fitted;
 - the spaces for MODU steering gear and thrusters;
 - positions at the fire and sprinkler pumps, at the emergency bilge pump and at their starting positions;
 - helicopter hangars and landing areas;
 - gyrocompass and other navigation equipment spaces;
 - medical rooms;
- .2** electric drives and alarm systems intended for life-saving appliances and personnel evacuation;
- .3** electric drives and control systems of the blowout preventer and of the gear disconnecting the MODU from the well head arrangement;
- .4** electric drives and control systems of permanently installed diving equipment;
- .5** electrical arrangements the operation of which is essential while the MODU is abandoned by personnel;
- .6** navigation lights and other lanterns required by the International Regulations for the Prevention of Collisions at Sea, in force;
- .7** all internal communication means, as well as a general alarm system;
- .8** radio and navigational equipment according to the requirements of Part IV "Radio Equipment" and Part V "Navigational Equipment" of the RS Rules/E;
- .9** fire and gas detection and alarm systems;
- .10** daylight signaling lamps, sound signal means (whistles, gongs, etc.), a manual call signal for responsible personnel and other kinds of alarms required under emergency conditions;
- .11** one of fire pumps and the electrical equipment ensuring the operation of foam generators specified in Part VI "Fire Protection" of the MODU Rules;
- .12** electric drives of watertight and fire doors with their indicators and alarms;
- .13** electric drives of ballast pumps, a ballast valve control system, a ballast and MODU condition indicating system which are necessary for emergency operations of submersible and semi-submersible MODU;
- .14** other systems the operation of which will be recognized by the Register as essential for the safety of the MODU and the personnel on board.

It is necessary to provide the supply of emergency visual, audible and signal navigation means required for MODU designation within at least 96 h from own accumulator batteries.

9.3.2 The emergency source of electrical power shall ensure supplying during 3 h the emergency lighting of embarkation stations for boarding lifesaving appliances on deck and overboard according to Part II "Life-Saving Appliances" of the RS Rules/E.

9.3.3 The emergency source of electrical power shall ensure supplying the steering gear, if any.

9.3.4 The emergency source of electrical power shall be:

.1 driven by an internal combustion engine having the characteristics specified in Part IX "Machinery" of the RS Rules/C and fitted with an alarm system;

.2 started automatically upon the voltage loss in the mains, and also automatically connected to the emergency switchboard busbars, and the services specified in [9.3.6](#) shall be automatically supplied from the emergency generator. The total time of starting and load take-over by the generator shall not exceed 45 s.

9.3.5 As a transitional emergency source of electrical power referred to in [9.1.1](#), an accumulator battery shall be used which shall operate without recharging, with voltage variations across its terminals within 12 % of rated voltage during the entire discharge period set in this Section.

9.3.6 The capacity of the battery serving as the transitional source of electrical power shall be sufficient for supplying the following services during 30 min:

.1 the emergency lighting and the essential clearance and navigation lights according to [9.3.1.1](#), [9.3.1.6](#), [9.3.1.12](#) and [9.3.2](#);

.2 all internal communication and announcing systems required in an emergency;

.3 general alarm system, fire and gas detection system and alarm on starting a fire-smothering system;

.4 daylight signaling lamps, sound signal means (whistles, gongs, etc.);

.5 public address system or a loudspeaker system specified in [7.2.7](#);

.6 closing gear of watertight and fire doors, their position indicators and signals warning of their closure.

The services listed in [9.3.6.2 to 9.3.6.6](#) may not be supplied from the transitional source if they have their own accumulator batteries supplying them within the set time.

9.4 DISTRIBUTION OF ELECTRICAL POWER FROM EMERGENCY SOURCES

9.4.1 Under normal operational conditions, an emergency switchboard shall be fed from the main switchboard. The emergency switchboard feeder shall have protective devices against an overload and a short circuit fitted at the main switchboard.

Provision shall be made for a circuit breaker at the emergency switchboard which shall switch off automatically in the case at de-energizing the main switchboard busbars.

Where the main switchboard is supplied from the emergency one, the circuit breaker at the emergency switchboard shall be fitted with at least short-circuit protective devices.

9.4.2 Where the emergency diesel-generator supplies non-emergency consumers in exceptional cases and for short periods of time, provision shall be made for:

.1 appropriate measures ensuring the operation of emergency arrangements under any emergency conditions;

.2 automatic disconnection of the non-emergency consumers from the emergency switchboard to ensure the supply of emergency services in case of an accident (fire, flooding).

9.4.3 The consumers listed in [9.3.1](#) shall be supplied by separate feeders from the busbars of the emergency switchboard fitted with appropriate switchgear and protection. The supply of the consumers listed in [9.3.1.2 — 9.3.1.12](#) may be effected from an integrated bridge control console located at the unit's bridge control station and supplied according to [4.4](#).

9.4.4 In order to prevent an inadvertent or unauthorized disconnection of the services listed in [9.3.6](#), these shall be supplied via the special switchboard which will be accessible for authorized personnel only.

9.4.5 The cables feeding emergency consumers shall run so that the flooding of the consumers below the bulkhead deck does not interrupt the supply of other consumers above that deck.

9.4.6 The distribution switchboards of emergency services shall be located above the bulkhead deck.

9.5 STARTING ARRANGEMENTS FOR EMERGENCY DIESEL GENERATORS

9.5.1 The following arrangements may be used as starting arrangements of emergency diesel generators:

- .1** electric starter with its own accumulator battery and charging device;
- .2** compressed air system with its own independent air receiver;
- .3** a hydraulic starting system;
- .4** manual starting arrangements:
inertia starters;
manually charged hydraulic accumulators;
powder charge cartridges.

9.5.2 Each emergency diesel generator shall be fitted with an automatic starting arrangement of the approved type with a stored energy capability of at least three consecutive starts. A second source of energy shall be also provided for an additional three starts within 30 min unless manual starting can be demonstrated to be effective.

9.5.3 The charging devices of accumulator batteries and the electric drives of the machinery ensuring the functioning of the compressed air or hydraulic starting systems of the emergency diesel generator shall be supplied from the emergency switchboard by separate feeders.

9.5.4 An emergency generator shall be capable of being readily started at the temperature of 0 °C in the space of the emergency diesel-generator.

9.5.5 Compressed air starting arrangements of the emergency diesel generator may be maintained by the main and auxiliary compressed air receivers, through a suitable non-return valve or by an emergency air compressor energized by the emergency switchboard.

9.5.6 All starting arrangements and charging devices of accumulators as well as the accumulators and other power storing devices for emergency diesel-generator starting shall be located in the emergency generator space and shall not be used for other purposes.

9.5.7 When automatic starting of an emergency diesel-generator is not provided, as being unjustified, and it may be demonstrated by the effectiveness of other way of starting, for instance, by manual inertia starters, manual hydraulic accumulators or powder cartridges, then these arrangements are covered by the requirements in [9.5.2](#) excepting the requirements for automatic starting.

9.6 EMERGENCY STATIONS AND EMERGENCY SHUTDOWN FACILITIES FOR ELECTRICAL EQUIPMENT

9.6.1 Provision shall be made for at least two independent emergency control stations on board the MODU. One of these shall be located near the drilling operation station and another one, in an appropriate manned space outside hazardous zones.

9.6.2 Emergency control stations shall be provided with:
manual self-return switches of a general alarm system;
independent communication facilities between these stations and all other control stations (the MODU bridge control station, the main control station of the machinery installation, etc.) ensuring the unit's safety;

means for the emergency shutdown of electrical equipment according to [9.6.3](#).

9.6.3 In an emergency, when, due to an uncontrolled well blow-out, hazardous zones fall outside the limits specified in [2.9](#), emergency switching means at emergency control stations shall provide the possibility of electrical equipment switching-off in the following sequence:

ventilation systems of spaces excepting the fans providing an air inflow essential for operation and cooling of the sets of the main source of electrical power;

all the electrical equipment outside the hazardous zone 1;

the sets of the main source of electrical power;

the services supplied from the emergency source of electrical power excepting the services specified in [9.3.6](#);

the emergency diesel-generator.

9.6.4 Irrespective of the remote emergency switching means specified in [9.6.3](#), when a fire-smothering system is activated, the ventilation of the space served is automatically and simultaneously to be switched off.

9.6.5 The sequence of the machinery switching-off specified in [9.6.3](#) may be altered depending on the specific emergency situations. The recommended sequence shall be given in the special instructions for operations in emergency situations.

9.6.6 The emergency switching-off system shall be designed so as to minimize the possibility of its inadvertent actuation or switching-off due to damages or mistakes in the control operations sequence.

9.6.7 Upon the emergency switching-off specified in [9.6.3](#), as a minimum the following explosion-proof electrical equipment shall continue functioning:

- .1 emergency lighting and navigation lights specified in [9.3.6.1](#) within 30 min;
- .2 preventer emergency control system;
- .3 general alarm system;
- .4 public address system;
- .5 radio equipment supplied from the accumulator batteries of stand-by source of electrical power.

Electrical equipment which is located in spaces other than enclosed spaces and which is capable of operation after the emergency shutdown as specified in [9.6.3](#) shall comply with the requirements of [2.11.7](#).

10 ELECTRICAL MACHINES

10.1 GENERAL

10.1.1 The materials of electrical machine shafts (of generators and motors) shall meet the requirements of Part XIII "Materials" of the RS Rules/C.

10.1.2 Excitation systems and automatic voltage regulators of alternating-current generators shall be capable to sustain, under steady short-circuit conditions, at least three-times the rated current within 2 s.

10.1.3 Generators of the main source of electrical power, machines of electric propulsion plant and, when justified, other essential electrical machines onboard the MODU shall have heating arrangements to maintain their temperature at least 3 °C above the ambient temperature.

10.1.4 Rotors and armatures of alternating and direct-current machines shall be capable of withstanding for 2 min, without damage and permanent set, the following increased rotational speed:

.1 generators, rotating converters and electric couplings and brakes – 120 % of the rated rotational speed, but at least by 3 % more than the maximum rotational speed during an equalizing (transient) process;

.2 series-wound motors – 120 % of the maximum permissible rotational speed as indicated on the rating plate, but not less than 150 % of the rated rotational speed;

.3 all the motors other than the above mentioned – 120 % of the maximum rotational speed.

10.1.5 Where a machine is so designed that after installation in the engine room its bottom portion is positioned below the floor level, ventilation air intake shall not be through the bottom portion of the machine.

10.1.6 Provision shall be made for prevention of moisture and condensate accumulation in electrical machine casing. Where liquid-cooled heat exchangers are used in electrical machines, their design shall be such that, in case of a leakage, a coolant could not permeate into the electrical machine. In this case, an alarm of a heat exchanger leakage shall be provided.

10.2 TERMINAL BOXES, SLIP RINGS, COMMUTATORS AND BRUSHES

10.2.1 Electrical direct-current machines rated at 200 kW and over shall be provided with sight holes to enable observation of a commutator and brushes without removing the lids.

10.2.2 The permissible wear value for commutator segments or slip rings shall be indicated on their sides. It shall be taken equal to at least 20 % of the commutators or slip rings height.

10.2.3 For armatures of over 1000 kg in mass, provision shall be made to allow reconditioning of the commutator without the removal of the armature from a machine.

10.2.4 Electrical machines shall have terminal boxes for the handy connection of external cables. The terminals shall be appropriately marked, reasonably sound and protected against an inadvertent contact with the housing and between poles or phases.

10.2.5 Terminal boxes shall have sufficient air gaps between the current-carrying parts of the terminal block and housing. The terminal boxes shall be so dimensioned that convenient arrangement of the terminations of finish leads and connected cables is ensured.

10.2.6 The position of brushes in direct-current machines shall be clearly and indelibly marked. The direct current machines shall be made so that they could operate in all modes with the permanent arrangement of brushes.

10.2.7 Commutator-type machines shall be capable of operating practically without sparking at any load from zero to rated value. No sparking shall develop at the specified overloads, reversal and start of the machines, to such an extent as to cause damage to brushes or commutators.

10.3 BEARINGS

10.3.1 Bearings shall be so designed as to avoid the opportunity of oil splashing or leaking along the shaft and coming into contact with the machine windings or live parts.

10.3.2 Plain bearing casings shall be fitted with a hole for excessive lubricating oil drain and with a lid in the upper part of the casing. Oil level indicators shall be provided on the machines rated at 100 kVA and over.

10.3.3 Pressure-lubricating system shall be fitted with a device for monitoring the pressure of the lubricating oil entering the bearing.

10.3.4 For electrical machines with plain bearings, measures shall be taken to prevent the flow of stray currents through the bearings.

10.4 TEMPERATURE DETECTORS

10.4.1 Stators of alternating current machines rated at over 5000 kW, or having a core length over 1000 mm shall be provided with temperature detectors located in those parts of the machine where the highest temperatures may be expected.

10.5 OVERCURRENT

10.5.1 Generators shall be so designed that after reaching the steady-state temperature corresponding to the rated load they shall be capable of sustaining overcurrent as specified in [Table 10.5.1](#).

Table 10.5.1

Type of generator	Overcurrent, %	Duration of overload, s
A.c. with ratings not more than 1200 kVA	50	30
A.c. with ratings more than 1200 kVA	50	15
D.c.	50	15

10.5.2 Electric motors shall be so designed that they are capable of developing, without stopping or sudden rotation frequency changes, the increased torque specified in [Table 10.5.2](#).

Table 10.5.2

Nos	Type of motor	Overload in torque, %	Duration of overload, s	Testing conditions
1	Synchronous motors, as well as squirrel-cage motors with starting current not less than 4,5 times the rated current	50	15	Frequency, voltage and excitation to be maintained at rated levels
2	Induction motors for continuous and intermittent duties	60	15	Frequency and voltage to be maintained at rated levels
3	Motors as specified in item 2, but for short-time and continuous duty with varying load	100	15	The same
4	Direct-current motors	50	15	Voltage to be maintained at rated level

10.5.3 For electric propulsion motors overload in torque and duration of overload are defined by the ship's designer taking into account changes in the main electric propulsion plant loads during maneuvering, sea passage, including navigation in difficult weather conditions, etc.

10.6 ALTERNATING-CURRENT GENERATORS

10.6.1 General.

10.6.1.1 Each alternating-current generator shall have a separate independent system of automatic voltage regulation.

10.6.1.2 Malfunctions in the voltage regulation system of generators shall not result in overvoltages at its terminals above the values stipulated by the maximum design excitation capacity.

10.6.1.3 Alternating-current generators shall have such a design that after heating up to a steady temperature corresponding to a rated load they could withstand a current overload of 50 % within 120 s.

10.6.1.4 Alternating-current generators shall possess sufficient excitation capacity to maintain the rated voltage with an accuracy of 10 % within 2 min at generator overcurrent equal to 150 % of the rated value and at a power factor 0,6.

10.6.2 Voltage regulation.

10.6.2.1 Alternating-current generators shall have automatic voltage regulation systems ensuring maintenance of the voltage within $\pm 2,5$ % (up to $\pm 3,5$ % for emergency generators) of the rated value at all load changes from no-load to rated load values at the rated power factor. A rotational speed therewith shall be within the range specified in Part IX "Machinery" of the RS Rules/C.

10.6.2.2 A sudden change in the balanced load of a generator running at a rated rotational speed and rated voltage, under given current and power-factor conditions, shall not result in a drop of voltage below 85 % or a rise over 120 % of a rated value. Following such a change, the generator voltage shall be restored to ± 3 % of a rated value within not more than 1,5 s. For emergency sets, these values may be increased up to 5 s in time and ± 4 % of the rated value in voltage.

Where no precise data are available on peak values of a sudden load being added to the existing generator load, these may be taken equal to a load of 60 % of a rated current at a power factor of 0,4 and less, which is connected at idle speed and then disconnected. The rotational speed in this case shall be within the range specified in Part IX "Machinery" of the RS Rules/C.

10.7 DIRECT-CURRENT GENERATORS

10.7.1 General.

10.7.1.1 Shunt-wound and separately excited direct-current generators shall be fitted with automatic voltage regulators.

10.7.1.2 Direct-current generators shall have such a design that after heating up to a steady temperature corresponding to a rated load, they could withstand a current overload of 50 % within 15 s.

10.7.2 Voltage regulation.

10.7.2.1 Manual voltage regulators of direct-current compound-wound generators shall enable reduction of no-load voltage, with the generator cold, by not less than 10 % below the rated generator voltage with due regard to the increased revolutions of the prime mover running at no load.

10.7.2.2 Manual voltage regulators shall be so designed that the voltage increases when their controls are rotated clockwise.

10.7.2.3 If the voltage of the generator with a shunt field winding (or a shunt and stabilized series field winding) is set to a rated value at a full load, then with the reduction of a generator down to a no-load running, the generator voltage shall not step up by more than 15 % of the rated value.

10.7.2.4 The voltage regulation devices specified in [10.7.2.1](#) shall have the regulation accuracy up to ± 1 % for generators rated up to 100 kW and up to $\pm 0,5$ % for generators of rating exceeding 100 kW. The above accuracy of these independent devices shall be maintained in a cold and hot state, and also at any load within the operating loads range of a generator.

10.7.2.5 Direct-current sets comprising compound-wound generators shall have such external characteristics that the voltage of a hot generator set to the rated value with an accuracy of ± 1 % at 20 % of the load does not vary at a full load by more than $\pm 1,5$ % for generators rated at 50 kW and over, and by more than 2,5 % for generators of lower output.

10.7.2.6 Voltage variations in a compound-wound generator running at 20 % to 100 % of the rated load shall not exceed the following limits:

- .1** ± 3 % for generators rated at 50 kW and over;
- .2** ± 4 % for generators rated over 15 kW but less than 50 kW;
- .3** ± 5 % for generators rated at 15 kW and less.

10.7.2.7 Direct-current sets comprising shunt-wound generators shall have such external generator characteristics and automatic voltage regulators that the voltage is maintained with an accuracy of $\pm 2,5$ % of the rated value at all load variations from zero to the rated load.

10.8 ELECTRIC MOTORS

10.8.1 Electric motors shall have such a design that they could develop increased torques specified in [Table 10.8.1](#) without a stop or sudden change of a rotational speed.

Table 10.8.1

Nos	Motor type	Torque overload, %	Duration, s
1	Synchronous and induction motors with $I_{start} = 4,5 I_{rated}$	50	15
2	Induction motors for continuous and intermittent duties	60	15
3	Induction motors for short- time duty with varying load	100	15
4	Direct current motors	50	15

10.8.2 It is recommended to provide for built-in temperature sensors in electric motors for short-time and intermittent duties.

10.8.3 In electric motors of anchor and mooring machinery drives, it is recommended to use overload protection as built-in temperature sensors so selected that a protection system switches off the electric motor when the temperature allowable for insulation of machine windings is exceeded by not more than 30 %.

The leads of sensors shall be located in an easily accessible place.

10.9 ELECTROMAGNETIC BRAKES

- 10.9.1** The brake shall operate when the brake-operating coil becomes de-energized.
- 10.9.2** A 30 % voltage drop below the rated value shall not cause a hot brake to operate.
- 10.9.3** Electromagnetic brakes shall make possible manual release.
- 10.9.4** Electromagnetic brakes shall be fitted with at least two pressure springs.
- 10.9.5** The shunt field windings of a compound-wound electromagnetic brake shall be capable of holding off the brake even when no current flows through the series winding.
- 10.9.6** The shunt field windings of electromagnetic brakes shall be so made or protected that they can be safe from damages at overvoltages occurring when they are being disconnected (refer also to [5.4.3](#)).

11 TRANSFORMERS

11.1 GENERAL

11.1.1 The requirements of this Section apply to power transformers specified in [3.3](#). The additional requirements for transformers with voltages over 1000 V are given in [Section 18](#).

11.1.2 It is allowed to use both dry-type and liquid-immersed (transformer oil) transformers onboard the MODU. Where transformers are located inside the spaces, they shall be of the dry- and natural-cooled type.

11.1.3 The transformers used for operation with semi-conductor converters shall be designed with due regard to potential distortions both in a supply frequency and voltage sinusoidalness.

11.1.4 Transformers shall have electrically-separated windings for primary and secondary voltages.

11.1.5 Where oil-immersed transformers are used, the following shall be taken into account:

- .1** transformers shall be of the leak-proof type; or
- .2** transformers shall be made so as to prevent the potential liquid overflow or leakage under all conditions of unit's operation including the maximum list and trim;
- .3** compensating devices of a cooling liquid for transformers shall be designed so as to prevent the potential leakage of the cooling liquid at any temperature variations;
- .4** the cooling liquid shall not be toxic and shall not sustain combustion;
- .5** provision shall be made for an alarm system on the maximum temperature of the cooling liquid and for the protection on presence of a gas in the cooling liquid.

11.1.6 Where forced cooling of transformers is used, provision shall be made for their potential operation at the reduced output if cooling pumps or fans fail. In this case, an alarm shall be provided as well.

11.2 OVERLOAD, VOLTAGE VARIATION AND OPERATION IN PARALLEL

11.2.1 Transformers shall withstand 10 % overloads for 1 h and 50 % overloads for 5 min.

11.2.2 Voltage variation at an active load between zero and rated load shall not exceed 5 % for transformers rated up to 6,3 kVA per phase and 2,5 % for transformers of higher rating.

11.2.3 Transformers intended for operation in parallel shall have their winding connections grouped together, the same transformation ratios, and their short-circuit voltages shall be such that the load on any transformer does not deviate from the value corresponding to the proportional part of each transformer power output by more than 10 % of the rated current for a given transformer.

11.2.4 Nominal capacities of transformers for operation in parallel shall not differ from one another more than twice.

12 POWER SEMICONDUCTOR UNITS

12.1 GENERAL

12.1.1 In power semiconductor units use shall be made of semiconductor elements of silicon type.

12.1.2 To prevent condensation in units based on semiconductor devices whose dissipation power is over 500 W, provision shall be made for heating to maintain the temperature at least 3 °C above the ambient air temperature.

12.1.3 Power semiconductor units shall be provided with natural or forced air cooling.

12.1.4 For power semiconductor units with forced cooling, provision shall be made for the protection reducing or disconnecting the load if the cooling is switched off.

An audible and visual alarm indicating the excess of the maximum permissible temperature of cooling medium at the system outlet prior to the protection activation shall be provided.

12.2 PERMISSIBLE PARAMETERS OF VOLTAGE DISTORTION

12.2.1 The harmonic distortion factor K_U for the unit's mains depending upon the operation of power semiconductor units shall not exceed 10 %.

The harmonic distortion factor shall be determined by the formula given in [2.2.1.3](#).

12.2.2 The factor of the maximum relative deviation of an instantaneous voltage value from the 1st harmonic value shall not exceed 30 %.

The factor ΔU_w shall be determined by the formula

$$\Delta U_w = \Delta U_m / (\sqrt{2}U_1) \quad (12.2.2)$$

where ΔU_m = maximum deviation value;
 U_1 = effective value of the 1st harmonic of voltage.

12.3 CONTROL AND ALARM SYSTEMS

12.3.1 Power semiconductor units shall be provided with a visual indication for connection and disconnection of power and control circuits.

12.3.2 The power section of semiconductor units shall be electrically isolated from a control system.

12.3.3 The long-term currents deviation in parallel branches of semiconductor units shall not exceed 10 % of an average current.

12.3.4 The operation of power semiconductor units shall not be disrupted by the failure of particular semiconductor elements. Where the load on the particular semiconductor elements exceeds permissible values, it shall be automatically reduced.

When some semiconductor elements fail, an audible and visual alarm shall be activated.

12.4 MEASURING INSTRUMENTS

12.4.1 Power semiconductor units shall be fitted with appropriate instruments for measuring the main input and output parameters of the unit.

12.4.2 The rated values of parameters shall be marked on instrument scales. Where a converter is force-cooled, the maximum permissible temperature shall be marked on the cooling air thermometer scale.

13 ACCUMULATOR BATTERIES

13.1 GENERAL

13.1.1 Accumulator batteries shall be so made that the loss of capacity of a fully charged battery due to self-discharge after 28 days out of operation at a temperature of $(25 + 5) ^\circ\text{C}$ does not exceed 30 % of rated capacity for acid batteries and 25 % for alkaline batteries.

13.1.2 Battery containers and closures for holes shall be so designed as to prevent spilling and splashing of an electrolyte when the container is inclined on any side to an angle of 40° from the vertical.

Closures shall be made of durable and electrolyte-resistant material. Closures design shall prevent the build-up of excessive gas pressure inside the battery.

13.1.3 The mastics used shall not change their properties or deteriorate at ambient temperature variations from $- 30 ^\circ\text{C}$ to $+ 60 ^\circ\text{C}$.

13.1.4 The materials used for making battery boxes shall be electrolyte-resistant. Individual cells placed in boxes shall be secured so as to prevent their relative displacements.

13.1.5 For the accumulator batteries intended for use as the electrical power source to supply the essential and emergency consumers a record book of the accumulator battery condition monitoring and maintenance shall be provided. This record book shall contain as a minimum the following information on the accumulator battery:

type and manufacturer of the accumulator battery;

voltage and capacity;

location;

description of the equipment and systems for which the accumulator battery is intended;

maintenance/replacement cycle dates;

date of last maintenance or replacement;

for replacement batteries in storage, the date of permissible shelf life (for the accumulator batteries intended for replacement and stored separately).

13.1.6 The MODU shall carry an instruction for replacement of accumulator batteries which shall indicate that the new accumulator battery shall have equivalent (identical) characteristics.

13.1.7 In case when a valve regulated sealed type accumulator battery is replaced by a vented type one, the space where accumulator battery shall be installed shall have adequate ventilation, as specified in [13.4](#).

13.1.8 The basic data of the accumulator battery maintenance log book shall be included into the unit's safe maintenance system documents which shall be supervised by the Register.

13.2 ARRANGEMENTS OF ACCUMULATOR BATTERIES

13.2.1 Batteries for a voltage above the safety one, as well as batteries having a charge capacity over 2 kW calculated on the basis of the maximum charging current and the rated voltage, shall be located in special battery compartments accessible from the deck, or in special boxes installed on the deck and provided with heating and ventilation.

Batteries having a charge capacity within the range of 0,2 to 2 kW may be installed in boxes or cabinets located in MODU special spaces.

Accumulator batteries intended for the electric starting of internal combustion engines, except for emergency sets, may be installed in machinery spaces in special boxes or cabinets with sufficient ventilation.

Batteries having a charge capacity under 0,2 kW, and also valve regulated sealed type accumulator batteries of unlimited charge capacity may be installed in any space, other than accommodation spaces, provided they are protected against touching current-carrying parts, water effect and mechanical damages, and do not adversely affect the surrounding equipment.

13.2.2 The acid and alkaline batteries shall not be placed in one space or in one box. The vessels and instruments intended for batteries with different electrolytes shall be placed separately.

13.2.3 The inside part of battery compartments or boxes, as well as all structural elements which may be subjected to adverse effects of an electrolyte or a gas, shall be suitably protected.

13.2.4 Accumulator batteries, and also individual cells shall be properly secured. If installed on racks in two or more tiers, these racks shall have a clearance of at least 50 mm on the face and back sides for air circulation, and the distance from the deck to the plugs in the upper tier of the cells shall not exceed 1500 mm.

13.2.5 When installing accumulator batteries or individual accumulators (cells), provision shall be made for fitting linings and spacers between them, which ensure a clearance for air circulation of not less than 15 mm on all sides.

13.2.6 Warning notices indicating the danger of explosion shall be provided on the doors leading to the battery compartment or nearby, and also on the boxes containing the accumulators.

13.3 HEATING

13.3.1 The battery compartments and boxes wherein a temperature in operation may fall down below 5 °C shall be fitted with a heating system. The heating is allowed to be effected by the heat from adjacent spaces, and also with water and steam radiators located inside the battery compartments or boxes.

13.3.2 The heating system valves shall be located outside the battery compartments.

13.3.3 The MODU general air conditioning system shall not be used as the main system for heating the battery compartments.

13.4 VENTILATION

13.4.1 Battery compartments provided with mechanical ventilation shall have devices, which prevent the possibility of switching on the accumulators for charging prior to the ventilation switch-on.

Charging cycle shall be automatically discontinued if the ventilators stop.

13.5 CHARGING OF ACCUMULATOR BATTERIES

13.5.1 Provision shall be made for charging facilities to charge the accumulator batteries of essential services within 8 h.

Where an additional battery is used instead of the one being charged, the charging time may exceed 8 h.

13.5.2 The charging facilities shall have means for measuring the voltage across battery terminals and the charging current, as well as the discharge current for temporary emergency sources of electrical power.

13.5.3 In MODU equipped with portable accumulator-fed lanterns or with spare accumulator-fed navigation lanterns the facilities shall be provided for charging the accumulators of these lanterns.

13.6 INSTALLATION OF ELECTRICAL EQUIPMENT IN BATTERY COMPARTMENTS

13.6.1 Apart from safe type lighting fixtures, heating appliances and automatic detectors of fire detection system, as well as cables led to accumulators, lighting fixtures, heating appliances and automatic detectors of fire detection system, no other electrical equipment shall be installed in battery compartments.

13.6.2 Cables led to accumulator batteries, lighting fixtures, heating appliances and automatic detectors of fire detection system may run openly, provided they have metal armour or braid covered with non-metal sheath and this metal armour or braid is reliably earthed at both ends.

13.7 ELECTRICAL STARTERS FOR INTERNAL COMBUSTION ENGINES

13.7.1 Number of starter batteries.

13.7.1.1 For electrically-started internal combustion engines, irrespective of their number, it shall be permanently installed:

at least two starter batteries for each two internal combustion engines with a potential switching of each battery for starting both engines;

at least two common starter batteries for starting all engines. In addition, provision shall be made for a permanent switching system that ensures the possible use of any battery for starting any engine in the group served by this battery.

13.7.2 Battery characteristics.

13.7.2.1 Each starter battery shall be designed to withstand a discharge current in a starter duty that corresponds to the maximum current through the most powerful starting electric motor.

13.7.2.2 The capacity of each battery shall be sufficient for six starts of an internal combustion engine in the ready-for-start condition, or in case of two or more engines, for not less than three starts of each engine.

13.7.2.3 Calculating battery capacity, the duration of each start shall be assumed not less than 5 s.

13.7.3 Charging facilities.

13.7.3.1 The charging facility of starter batteries shall be supplied by a separate feeder from the main switchboard even if the battery is charged from the internal combustion engine-driven generator.

14 ELECTRICAL APPARATUS AND ACCESSORIES

14.1 ELECTRICAL APPARATUS

14.1.1 General.

14.1.1.1 The design of switches with renewable contacts shall be such that renewal of the contacts could be made with standard tools without dismantling the switch or its basic components.

14.1.1.2 All disconnectors and switches, except those for cabins, shall be fitted with mechanical or electrical contact position ("ON" — "OFF") indicators located in the place from which the apparatus is actuated by the operator.

14.1.1.3 The positions of controller and master controller drums shall be rigidly locked by mechanical means, location in zero position being more rigid than elsewhere.

The controller and master controller drums shall be fitted with a scale and an indicator of "ON" position.

14.1.1.4 Control gear, other than used for continuous smooth regulation, shall be made so that the end and intermediate fixed positions are easy to feel at various control steps while the movement beyond the end positions shall be impossible.

14.1.2 Manually operated controls.

14.1.2.1 The direction of movement of manual controls of switchgear or control gear shall be such that the clockwise rotation of a handle (handwheel) or the displacement of a handle (lever) up or forward corresponds to apparatus closing, electric motor starting, rotational speed increase, voltage stepping-up, etc.

When lifting or lowering mechanisms are under control, the clockwise rotation of a handle (handwheel) or the shifting of a handle (lever) toward the operator shall correspond to lifting while the counterclockwise rotation or shifting away from the operator, to lowering.

14.1.2.2 Switch push buttons shall be so designed that they cannot be actuated accidentally.

14.1.3 Motor operated gear.

14.1.3.1 The actuator of circuit breakers and other switches shall be so designed that in the event of loss of supply to the actuating motor, the switch or circuit breaker contacts remain in closed or open position only.

14.1.3.2 An electric motor actuator shall provide for reliable closing of the apparatus at the voltage supply within 85 to 110 % of the rated value, and in case of an alternating current, at frequency deviations within ± 5 % of the rated value at the ambient temperature of 45 °C and with the heated actuator winding.

14.1.3.3 The operation of an actuator at 110 % of the rated voltage shall not result in damages to the switch or in excessive effect on contacts affecting the commutation capability of the apparatus. The above requirement with relation to electro-magnetic contactors shall be fulfilled when the contactor is being closed at the ambient temperature of -10 °C and with the heated coil winding.

14.1.3.4 A voltage drop down to 70 % of the rated actuator supply voltage shall not cause main and auxiliary contacts opening or decrease of contact pressure at the ambient temperature of 45 °C and with the heated actuator winding.

14.1.3.5 The design shall provide for the possibility of the manual control of a motor-operated switch.

14.1.4 Coils.

14.1.4.1 A conductor or a lug shall be attached to a coil winding in such a way that the forces from the conductor connected are not transmitted to the coil turns. The taps of voltage coils shall be made of flexible multiwire conductor, except when contact terminals are directly secured to the coil frame.

14.1.4.2 The coils of electromagnetic apparatus shall bear notations giving the particulars of their characteristics.

14.1.5 Fuses.

14.1.5.1 Fuse link housings shall be of the totally enclosed type. The melting-down of a fusible element shall not cause an arc ejection to the outside, sparking or any other harmful effect upon the nearby parts of electrical equipment.

14.1.6 Resistors.

14.1.6.1 Resistor elements shall be easily replaceable, in sections or in total.

14.1.6.2 Ballast resistor blocks shall be so arranged and ventilated that they do not heat other devices beyond the permissible limits.

14.1.6.3 The additional requirements for earthing circuits of networks with voltage over 1000 V are specified in [Section 18](#).

14.2 ELECTRICAL ACCESSORIES

14.2.1 General.

14.2.1.1 The enclosures of accessories and fittings shall be made of materials of adequate mechanical strength which are corrosion-resistant or properly protected against corrosion and, at least, flame-retardant. The enclosures of accessories and fittings designed for installation on the open deck, in refrigerated cargo spaces and humid areas shall be made of brass, bronze or equivalent material, or of plastics of proper quality. Where steel or aluminium alloys are used, the proper anti-corrosive protection shall be provided.

It is inadvisable to use threaded connections or tight-fit mating of parts in accessories and fittings made of aluminium alloys.

14.2.1.2 Insulating parts, to which current-carrying components are attached, shall be made of materials that do not evolve gases ignited from an electric spark at a temperature of up to 500 °C.

14.2.1.3 The lighting fixtures to be mounted on or close to combustible materials shall be designed so as to prevent their heating over 90 °C (refer also to [6.5.8](#)).

14.2.2 Lampholders.

14.2.2.1 The design of lampholders fitted with a screw cap shall be such as to effectively prevent the lamps from getting loose in service.

14.2.2.2 No switches are allowed to be fitted in lampholders.

14.2.2.3 Each lighting lampholder shall be marked to indicate the rated voltage, and also the maximum allowable current or power.

14.2.3 Plug-and-socket connectors.

14.2.3.1 The pin jacks of socket outlets shall be so designed as to ensure permanent pressure in contact with the plug pins.

14.2.3.2 Plugs with slotted pins are not allowed for use. The pins of plugs designed for currents over 10 A shall be cylindrically shaped, solid or hollow.

14.2.3.3 Socket outlets and plugs for voltages exceeding the safety one shall have contacts for connecting the earthing conductors of incoming cables from current consumers.

14.2.3.4 Socket outlets shall be so designed that the proper protection degree is ensured regardless of whether the plug is in or out of the socket outlet.

14.2.3.5 Socket outlets rated over 16 A shall be provided with built-in switches. Provision shall be also made for interlocking such socket outlets to prevent the possibility of the plug being inserted or withdrawn while the socket switch is in the "ON" position.

14.2.3.6 Where socket outlets are not interlocked, the clearance between contacts in air and across the insulation surface shall be such that no short circuit is possible due to arcing over when the plug is withdrawn while carrying a load by 50 % above the rated current at the rated voltage.

14.2.3.7 Socket outlets and plugs shall be so designed that it is not possible to insert living pins into the earthing jack. Besides the design of the outlets intended for connecting motors (devices) direction of rotation of which depends on the change of phases or poles sequence, shall exclude the possibility of the sequence change. When the plug is inserted into the socket outlet, the earthing part of the plug shall make contact with the earthing part of the socket outlet before connecting the living pins.

14.2.3.8 No fuses shall be fitted in socket outlets and plugs.

14.2.3.9 The socket outlets design shall rule out the possibility of connection to them of the plugs of consumers designed for a lower voltage.

14.2.3.10 Socket outlets on open decks shall be mounted with their face looking downward, and the cable connected to them shall not get through the coamings of doors or through other openings to be closed which open into hazardous spaces and areas.

15 ELECTRICAL COOKING AND HEATING APPLIANCES

15.1 GENERAL

15.1.1 Only stationary-type electrical cooking appliances are permitted for use.

15.1.2 Electrical cooking appliances shall be supplied from the main switchboard or from distribution boards intended for this purpose, and also from lighting switchboards with regard to the requirements of [6.2.1](#).

15.1.3 The supporting structural parts of electrical cooking appliances, as well as the internal surfaces of enclosures shall be made of non-combustible materials.

15.1.4 In heated condition, a permissible leakage current shall not exceed 1 mA per 1 kW of the rated power for any separately connected heating element or 10 mA for the appliance as a whole.

15.1.5 Electrical cooking appliances shall be so designed that the temperature of their components which shall be handled by the personnel or which can be touched inadvertently, does not exceed the values specified in [Table 15.1.5](#).

Table 15.1.5

Nos.	Item	Permissible temperature, °C
1	Control handles for prolonged use:	
	metallic	55
	non-metallic	65
2	Same, but for short-time use:	
	metallic	60
	non-metallic	70
3	Enclosures of electrical cooking and heating appliances in spaces at the ambient temperature of 20 °C	80
4	Air coming out from heating appliances into the heated space	110

15.2 HEATING APPLIANCES

15.2.1 Electrical heating appliances intended for space heating shall be stationary. These shall be provided with devices disconnecting the supply source if the temperature rise of the appliance enclosure exceeds the permissible limit.

15.2.2 Heating appliances shall be installed according to the requirements of 2.1.13, Part VI "Fire Protection" of the MODU Rules.

15.2.3 If heating and cooking appliances are not provided with built-in disconnecting devices, then such devices shall be installed in the space in the immediate vicinity of these appliance enclosures. Switches shall disconnect power supply at all poles or phases.

15.2.4 The design of electrical heating appliance enclosures shall prevent the possibility of any objects being placed upon them.

15.2.5 Stationary heating appliances rated at 380 V and allowed for use in accordance with [Table 4.1.5](#) shall be protected against access to live parts without the aid of special tools. The enclosures shall have notices giving the voltage value.

15.2.6 Electrical cooking appliances being part of galley equipment shall be so designed as to prevent the possibility of the kitchenware contact with live parts, and a short circuit or damage to insulation due to a liquid overflow.

15.3 PETROLEUM PRODUCT HEATERS

15.3.1 Petroleum products (fuel oil and lubricating oil) having a flash point above 60 °C may be heated by means of electric heaters provided the requirements of [15.3.2](#) and [15.3.3](#) are fulfilled.

15.3.2 Electric heaters for pipelines shall be fitted with temperature control means, a visual alarm of operation modes, and also with a visual and audible alarm of malfunctions and the temperature rise above the permissible level.

15.3.3 Electric heaters in tanks shall be of the indirect heating type and fitted with means for control of the temperature of the medium heated, with sensors of heating coils surface temperature, with low level indicators and means for the disconnection of power supply to the heaters in case the upper temperature limit and the lowest permissible level are exceeded.

15.3.4 Irrespective of the type of the electric device for heated medium temperature control, a manually disengaged device for de-energizing the heaters on reaching the heating coil surface temperature of 220 °C shall be provided.

15.3.5 Heating cables and electric surface heaters shall be supplied by separate feeders with a rated current not exceeding 63 A.

15.3.6 Suitable protection against mechanical damages shall be provided for heating cables and surface heaters. Appropriate notices shall be also provided to warn the personnel about the prevention of any mechanical damages to the pipelines fitted with the heating cables.

15.3.7 Heating cables and surface heaters in hazardous areas may be used only with the appropriate explosion protection type confirmed with competent body certificates.

15.4 SYSTEM UTILISING HEATING CABLES

15.4.1 System utilising heating cables for removing ice and avoiding icing shall be provided for equipment and spaces intended for the following:

designed functioning of an installation (process equipment);

maintenance of steerability;

maintenance of stability;

safety of crew (process pads, ladders, guard rails, rafts, lifeboats, etc.).

15.4.2 Heat output of such systems shall be at least:

300 W/m² for the spaces of open decks, helidecks, ladders and gangways;

200 W/m² for superstructures;

50 W/m² for guard rails with internal heating.

Heat output for other areas and spaces is subject to special consideration by the Register in each particular case.

15.4.3 In the system utilising electrical heating cables particular attention shall be paid upon the heat transfer between the cable to the equipment (spaces) to be heated to provide efficient heating.

15.4.4 Switchboard for the above systems shall be equipped with:

wattmeter or ammeter for total load indication;

nameplate indicating the design load for each circuit, as well as for the switchboard on the whole;

earth fault monitoring unit for each circuit with warning alarm;

signal lamps indicating switching-on of the load for each circuit.

15.4.5 Two-wire heating cables shall have overload protection of 125 % of the rated current. For self-regulating cables the overload protection may be dispensed with.

16 CABLES AND WIRES

16.1 GENERAL

16.1.1 The requirements of this Section apply to power cables and wires for voltage up to 1000 V and to control and signal cables. Additional requirements for cables for voltage over 1000 V and the conditions of their running are given in [Section 18](#).

16.2 CABLE CONDUCTORS

16.2.1 Cables intended for supplying essential services shall have stranded conductors and shall be made of electrolytic copper (refer also to [16.8.1.2](#)). [Table 16.2.1](#) specifies the minimum number of wires per conductor. Solid conductors are allowed only for mineral-insulated cables and for cables having the cross-sectional area up to 2,5 mm² and voltage up to 250 V, which are run through accommodation spaces.

Table 16.2.1

Nominal cross-sectional area of conductor, mm ²	Minimum number of wires per conductor	
	Circular non-tightened conductors	Tightened sector and circular conductors
0,5 – 6	7	
10–16	7	6
25 – 35	19	6
50 – 70	19	15
95	37	15
120–185	37	30
240 – 300	61	30

Note. The ratio between the nominal diameters of any two wires in the mechanically-tightened cables conductor shall not exceed the value 1:1,3, and for conductors formed geometrically, but not tightened, 1:1,8.

16.2.2 Connections of separate conductor wires shall be displaced from one another by not less than 500 mm along the length of the conductor.

Such connections shall not impair the mechanical and electrical properties of the wire nor change the cross-sectional area of the wire and the conductor as a whole.

16.2.3 Separate wires of rubber-insulated copper conductors shall be tinned or coated with a suitable alloy.

Tinny or other corrosion-resistant coating of an external lay or of all wires of a rubber-insulated conductor may be unnecessary if the manufacturer takes measures to assure that the rubber insulation does not adversely affect the conductor metal.

No tinning is needed for conductors having other types of insulation.

16.3 INSULATING MATERIALS

16.3.1 Insulating materials specified in [Table 16.3.1](#) may be used for conductors of cables and wires.

Table 16.3.1

Insulation designation	Standard types of insulating materials	Permissible service temperature of a wire for calculation of permissible long-duration cable load, °C
PVC/A	Standard-type polyvinylchloride	60
PVC/D	Heat-resistant polyvinylchloride	75
EPR	Ethylene-propylene rubber	85
XLPE	Cross-linked polyethylene	85
S95	Silicon rubber	95

16.4 CABLE SHEATHING

16.4.1 Protective sheathing of cables and wires may be made of non-metal materials specified in [Table 16.4.1](#), of lead and copper.

Table 16.4.1

Sheathing designation	Non-metallic protective sheathing type	Maximum permissible temperature of cable conductors, °C
SV1	Polyvinylchloride	60
SV2	Same, but heat-resistant	85
SP1	Polychloroprene rubber	85
SH1	Chlorosulfonated polyethylene	85

16.4.2 Protective sheathing shall be of uniform thickness within allowable limits, throughout the manufacturing length of a cable, and shall concentrically envelop the cable conductors. The sheaths shall form an impervious covering in tight contact with the protected conductors.

16.4.3 Lead cable sheaths shall be made of relevant alloys specified by national standards.

Pure lead sheaths may only be used when the lead sheath is covered with an additional protective sheath.

16.4.4 The sheaths of electric cables and wires shall, as a minimum, not propagate combustion and not lose in service its properties, which ensure non-propagation of combustion.

16.5 PROTECTIVE COVERINGS

16.5.1 A shielding braid shall be made of tinned copper wire. If plain copper wire is used, it shall be protected with a proper sheath. Non-shielding braids may be made of galvanized steel wire. The braid shall be uniform and its density shall be such that its mass is at least equal to 90 % of the mass of the same diameter tube made of the same material and having a wall thickness equal to the braiding wire diameter.

16.5.2 Metal armour shall be made of annealed and galvanized steel wire or tape wound helically, with a relevant pitch, over the cable sheath or an intermediate bedding over the sheath in such a way that a continuous cylindrical layer is formed providing protection and flexibility of the finished cable. On special demand, the armour may be made of nonmagnetic metals using the above technique.

16.5.3 Cables armour or braid made of steel tape or wire shall be properly protected against corrosion.

16.5.4 Armour bedding shall be made of moisture-resistant materials.

16.6 MARKING

16.6.1 Rubber- or polyvinylchloride-insulated cables for ultimate temperatures at core over 60 °C shall be marked in a way allowing their identification.

16.6.2 Cable cores shall be marked in a way assuring adequate preservation of the marking.

In multi-core cables with cores arranged in several concentric layers, at least two adjacent cores of each layer shall be marked with different colours.

16.7 HOOKUP WIRES

16.7.1 For internal wiring of distribution boards and electric devices, solid insulated conductors shall be used (refer also to [Table 16.3.1](#)).

16.7.2 Non-insulated wires and busbars may be used for internal wiring of electrical devices. The external wiring with non-insulated wires or busbars is not allowed unless they are reliably guarded.

16.8 CABLING

16.8.1 General.

16.8.1.1 Use shall be made of flame-retarding or non-combustible cables and conductors with copper cores manufactured and tested in accordance with the requirements of this Part of the Rules, national standards, as well as complying the relevant requirements of IEC standards: 60092-350:2020, 60092-352:2005, 60092-353:2016, 60092-354:2020, 60092-360:2014, 60092-370:2019, 60092-376:2017. Cables shall be tested for flame propagation in compliance with the requirements of IEC 60332-1-2:2004+AMD:2015 and 60332-3-22:2018.

Cables manufactured and tested in compliance with standards other than those specified above, may be used on ships provided that they comply with the requirements of international and national standards and on safety level are equivalent to or exceeding the standards specified above.

The use of flexible cables, fiber optic cables, etc. used for special purposes may be permitted provided they are manufactured and tested in accordance with approved standards.

In this case, IEC 60331-23 for data transfer cables and IEC 60331-25 for optical fibre cables may be used.

In respect of fire resistance cable tests, the following IEC standards shall be used: IEC 60331-1 — for cables with the outer diameter above 20 mm and IEC 60331-21 or IEC 60331-2 — for other cables.

16.8.1.2 Cables and wires with stranded conductors shall be used, and the cross-sectional area of the conductor shall be not less than:

.1 1,0 mm² — for supply, control and signalling circuits of essential services and for supply circuits arrangements;

.2 0,5 mm² — for control and signaling circuits;

.3 0,5 mm² — with the number of cores in the cable not less than four for instrumentation and internal communication circuits.

Cables with a single-wire conductor having a cross-sectional area of 1,5 mm² and less may be used for supply of non-essential services. The core number in supply cables shall correspond to the phase or polarity of the distribution network.

High-frequency cables with core diameters of 0,4 — 0,8 mm complying with the requirements of IEC 61156-5:2020 may be used in data transmission circuits, taking into account the mechanical strength of such cables in accordance with IEC 60092-370:2019.

16.8.1.3 In circuits with heavy inductive and capacitive loads, the use shall be made of cables designed for a working voltage approximately equal to double the rated voltage of the circuit.

16.8.1.4 The maximum permissible temperature for the insulating material of the cable core or wire used shall be at least 10 °C higher than the maximum specified ambient temperature.

16.8.1.5 In locations exposed to the action of petroleum products or other aggressive medium, the use shall be made of cables having a sheath, which is resistant to such medium. The cables not possessing such properties may be laid in such location in metallic pipes only (refer to [16.8.8](#)).

16.8.1.6 In locations where cables may be subjected to mechanical damages, the use shall be made of cables having a proper armour, while the cables of other types in such locations shall be suitably protected or laid in pipes (refer to [16.8.8](#)).

16.8.1.7 The cables supplying the electric drives of a sprinkler system and a fire pump from the emergency source of electrical power and running through the casings of Category A machinery spaces, galleys, drying rooms and other similar fire-hazardous spaces, shall be non-combustible or protected from exposure to flame. The above requirements also cover the remote control cables of those devices.

The cables shall be laid so as to prevent their damage due to bulkheads heating which may be caused by a fire in an adjacent space.

16.8.1.8 Cables for essential and emergency services, as well as cables for services required for operation under fire conditions, including their feeding cables, shall be routed clear of high fire risk machinery spaces (refer to [16.8.1.9](#)), except for cases when the services themselves are installed in such spaces.

Where such installation of cables is necessary, the cables shall be of fire-resistant type.

16.8.1.9 The high fire risk spaces include the following:

machinery spaces of category A;

spaces, in which equipment for pretreatment of fuel and other flammable substances is installed;

galley and their service spaces, in which cooking equipment is installed;

laundries, in which drying equipment is installed;

accommodation spaces of high fire risk;

paint rooms, store rooms and similar spaces for storage of flammable liquids;

enclosed and semi-enclosed hazardous spaces, in which explosion-proof electrical equipment shall be installed.

16.8.1.10 Cables, distribution gears, switch apparatus or protective devices, electrical accessories associated therewith shall be so designed or installed that the likelihood of the device failing in case of fire in any one such space or area is minimized.

16.8.1.11 Among the arrangements required to be operable under fire conditions are the following:

general alarm;

fire extinguishing systems;

fire detection and fire alarm systems;

warning alarm of fire extinguishing system release;

controls of fire doors with door-position indicators;

controls of watertight doors with door-position indicators and warning alarm;

emergency lighting;

public address system;

low-location lighting;

remote emergency shutdown control for the systems, the operation of which may maintain spreading of fire and/or explosion.

16.8.1.12 Cables of the arrangements specified in [16.8.1.11](#) running through high fire risk spaces shall be fire-resistant from the control panel up to the nearest distribution panel serving the relevant area or zone.

16.8.1.13 Feeding cables of the arrangements specified in [16.8.1.10](#) running through high fire risk spaces shall be fire-resistant from the emergency source of power up to the nearest distribution panel serving the relevant area or zone.

16.8.1.14 Cables of devices required for operation under fire conditions including their supplying cables shall be of fire-resistant type if they pass through Category A machinery spaces, boiler rooms, galley and other enclosed spaces of high fire risk, as well as through their casings, fire zones or decks other than those in which they are fitted. Such devices include:

general alarm system and fire detection system;

fire extinguishing systems and alarm warning of starting a fire smothering system;

fireproof door controls with door position indicators;

control of watertight doors with door-position indicators and warning alarm;

emergency lighting;

service communication and public address system;

low location lighting.

16.8.2 Selection of cables and wires by loads.

16.8.2.1 The calculation of permissible current loads shall be carried out basing on the standards or calculation methods approved by the Register. Continuous permissible current loads for single-core cables and wires with different insulating materials at the ambient temperature of 45 °C shall comply with the values specified in [Table 16.8.2.1](#).

Table 16.8.2.1

Nominal cross sectional area of conductor, mm ²	Insulating material					
	Polyvinylchloride	Heat-resistant polyvinylchloride	Butyl rubber	Ethylene-propylene rubber, cross-linked polyethylene	Ethylene-propylene rubber, cross-linked polyethylene and polyolefine	Silicon rubber or mineral insulation
	Maximum working permissible temperature of conductor, °C					
	60	75	80	85	90	95
1	8	13	15	16	18	20
1,5	12	17	19	20	23	26
2,5	17	24	26	28	30	32
4	22	32	35	38	40	43
6	29	41	45	48	52	55
10	40	57	63	67	72	76
16	54	76	84	90	96	102
25	71	100	110	120	127	135
35	87	125	140	145	157	166
50	105	150	165	180	196	208
70	135	190	215	225	242	256
95	165	230	260	275	293	310
120	190	270	300	320	339	359
150	220	310	340	365	389	412
185	250	350	390	415	444	470
240	290	415	460	490	552	553
300	335	475	530	560	601	636

The current loads given in this Table applies to the following cases of cable laying:

- .1 for laying not more than 6 cables in one bunch or in one row fitted tightly together;
- .2 for laying cables in two rows irrespective of the number of cables in one row subject to a free space for air circulation is provided between each group or bunch of 6 cables.

Where more than six cables, which may be under rated current simultaneously, are laid in a bunch or where no free space for air circulation between the cables is provided, the permissible current loads for the given cross-section specified in [Table 16.8.2.1](#) shall be reduced by 15 % (factor 0,85).

16.8.2.2 The values of rated current loads in amperes for the cross-sections in [Table 16.8.2.1](#), and also for any cross-section are calculated by the formula

$$I = \alpha S^{0,625} \tag{16.8.2.2}$$

where α = factor corresponding to the maximum permissible working temperature of the conductor according to [Table 16.8.2.2](#);
 S = nominal cross-sectional area of the conductor, in mm².

Table 16.8.2.2

Maximum permissible temperature of conductor, °C	Factor α for nominal cross-sectional area S , mm ²	
	$\geq 2,5$	$< 2,5$
60	9,5	8
65	11	10
70	12	11,5
75	13,5	13
80	15	15
85	16	16
90	17	18
95	18	20

16.8.2.3 The permissible current loads for double-, three- and four-core cables shall be determined by reducing the values given in [Table 16.8.2.1](#) for the given cross-section using the following correction factors:

- 0,85 for double-core cables;
- 0,70 for three- and four-core cables.

16.8.2.4 The permissible current loads of cables and wires in circuits with an intermittent or short- time load shall be determined by multiplying the continuous cable loads specified in [Table 16.8.2.1](#) or selected according to [Table 16.8.2.2](#) by the correction factors given in [Table 16.8.2.4](#).

Table 16.8.2.4

Correction factor for cables and wires with or without metallic sheathing

Nominal cross-section of conductor, mm ²	Intermittent mode, cyclic duration factor 40 %		Short-time operation, 30 min		Short-time operation, 60 min	
	Cables and wires					
	with metallic sheathing	without metallic sheathing	with metallic sheathing	without metallic sheathing	with metallic sheathing	without metallic sheathing
1,09	1,24	1,09	1,06	1,06	1,06	1,06
1,5	1,26	1,09	1,06	1,06	1,06	1,06
2,5	1,27	1,10	1,06	1,06	1,06	1,06
4	1,30	1,14	1,06	1,06	1,06	1,06
6	1,33	1,17	1,06	1,06	1,06	1,06
10	1,36	1,21	1,08	1,06	1,06	1,06
16	1,40	1,26	1,09	1,06	1,06	1,06
25	1,42	1,30	1,12	1,07	1,06	1,06
35	1,44	1,33	1,14	1,07	1,07	1,06
50	1,46	1,37	1,17	1,08	1,08	1,06
70	1,47	1,40	1,21	1,09	1,09	1,06
95	1,49	1,42	1,25	1,12	1,11	1,07
120	1,50	1,44	1,28	1,14	1,12	1,07
150	1,51	1,45	1,32	1,17	1,14	1,08
185	–	–	1,36	1,20	1,16	1,09
240	–	–	1,41	1,24	1,18	1,10
300	–	–	1,46	1,28	1,20	1,12

16.8.2.5 The permissible current loads specified in [Table 16.8.2.1](#) are given for an ambient temperature of 45 °C.

The correction factors for conversion of the permissible loads to be used depending on the ambient temperature are given in [Table 16.8.2.5](#).

Table 16.8.2.5

Ultimate conductor temperature, °C	Ambient temperature, °C										
	35	40	45	50	55	60	65	70	75	80	85
60	1,29	1,15	1,00	0,82	–	–	–	–	–	–	–
65	1,22	1,12	1,00	0,87	0,71	–	–	–	–	–	–
70	1,18	1,10	1,00	0,89	0,77	0,63	–	–	–	–	–
75	1,15	1,08	1,00	0,91	0,82	0,71	0,58	–	–	–	–
80	1,13	1,07	1,00	0,93	0,85	0,76	0,65	0,53	–	–	–
85	1,12	1,06	1,00	0,94	0,87	0,79	0,71	0,61	0,50	–	–
90	1,10	1,05	1,00	0,94	0,88	0,82	0,74	0,67	0,58	0,47	–
95	1,10	1,05	1,00	0,95	0,89	0,84	0,77	0,71	0,63	0,55	0,45

16.8.2.6 Selecting the cables for final branch circuits of lighting and cooking appliances, correction or simultaneity factors shall not be used.

16.8.2.7 The cables shall be so designed that they could withstand the maximum short-circuit current with due regard to current and time ratings of protective devices and to the peak value of the prospective short-circuit current of the first one-half period.

16.8.2.8 The cables laid in parallel for the same phase or pole shall be of the same type, laid together and to have the same cross-sectional area of at least 10 mm² and the same length.

16.8.3 Selection of cables cross-sectional area for permissible voltage drop.

16.8.3.1 Voltage drop on the cable connecting generators to the main and emergency switchboard shall not exceed 1 %.

16.8.3.2 Voltage drop between the busbars of the main or emergency switchboard and any points of the installation under normal operational conditions shall not exceed 6 % of the rated voltage, and for services supplied from an accumulator battery with the rated voltage up to 50 V, this value may be increased up to 10 %. For transient processes, e.g. when electric motors are started, the short-time voltage drop in excess of 10 % may be permitted.

For navigation lights circuits, it may be required to limit the voltage drop by a lesser value in order to ensure necessary luminous intensity.

16.8.3.3 The cables feeding directly-started alternating-current electric motors shall be computed in such a way that the voltage drop on motor terminals at starting does not exceed 25 % of the rated voltage.

16.8.3.4 Cables used for connection of onboard equipment to the own supply units as regards the voltage drop, shall be selected based on technical characteristics of such equipment.

16.8.4 Cable laying.

16.8.4.1 Cables shall be laid in runs which are, as practicable, to be straight and accessible to prevent their twisting and other mechanical effects that may cause their damage. The cable runs shall pass through locations where the cables are not subjected to long exposure to lubricating oil, fuel oil, water and excessive external heating. The cable runs shall be at least 100 mm away from heat sources.

16.8.4.2 No cables shall be laid within 50 mm from the double bottom and petroleum product tanks.

The cables shall be at least 20 mm away from the shell plating, as well as from fireproof, watertight and gastight bulkheads and decks.

16.8.4.3 Where cable bunches not tested for flame spreading are laid, the following measures shall be taken:

.1 fire-retarding divisions shall be used, "B-0" class at least (refer also to 2.1.2.9, Part VI "Fire Protection" of the RS Rules/C), where the bunches enter the main and emergency

switchboards, central control panels and consoles for the powerplant and essential machinery, and also at each end of fully enclosed cable runs (refer to [Fig. 16.8.4.3.1](#));

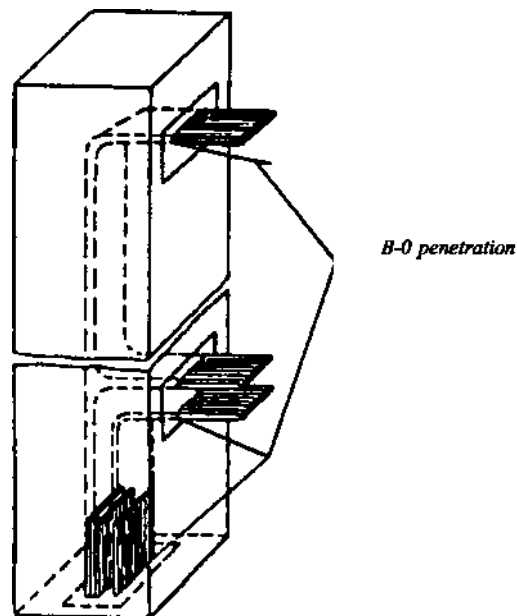

Fig. 16.8.4.3.1
Fully enclosed cable run protection with B-0 fire-retarding division

.2 in enclosed and semi-enclosed rooms and spaces, cable bunches laid in partly enclosed and open cable runs shall be protected with:

a fire-resistant coating over the entire length of vertical cable runs and over a length of 1 m every 14 m apart for horizontal cable runs (refer to [Fig. 16.8.4.3.2-1](#)); or

"B-0" fire-retarding Class divisions at least on every second deck or every 6 m apart for vertical cable runs, and every 14 m apart for horizontal cable runs (refer to [Fig. 16.8.4.3.2-2](#)). Fire-retarding divisions shall be made of steel plates at least 3 mm thick and dimensioned as shown in [Fig. 16.8.4.3.2-2](#).

16.8.4.4 Cables having external metallic sheaths may be laid on structures of light metal or fastened with staples of light metal only when reliable corrosion protection is provided.

16.8.4.5 Cable laying under the flooring of machinery spaces in the ordinary way is not allowed. Where such laying is required, cables shall be enclosed in metallic pipes or conduits (refer to [16.8.8](#)).

16.8.4.6 Cables laid across expansion joints in the hull structures shall have expansion loops of a radius adequate for such joint. The inside diameter of the loop shall be not less than 12 outside diameters of the cable.

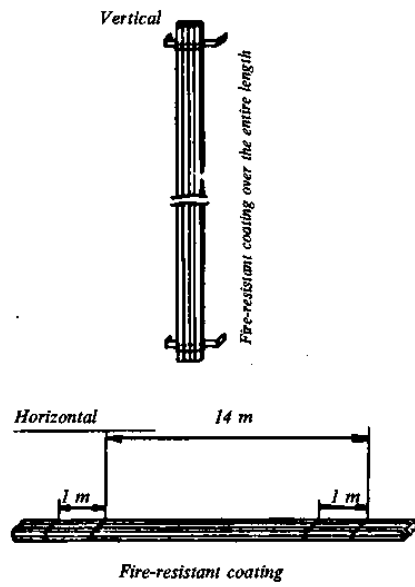

Fig. 16.8.4.3.2-1
Cable run protection with fire-resistant coating

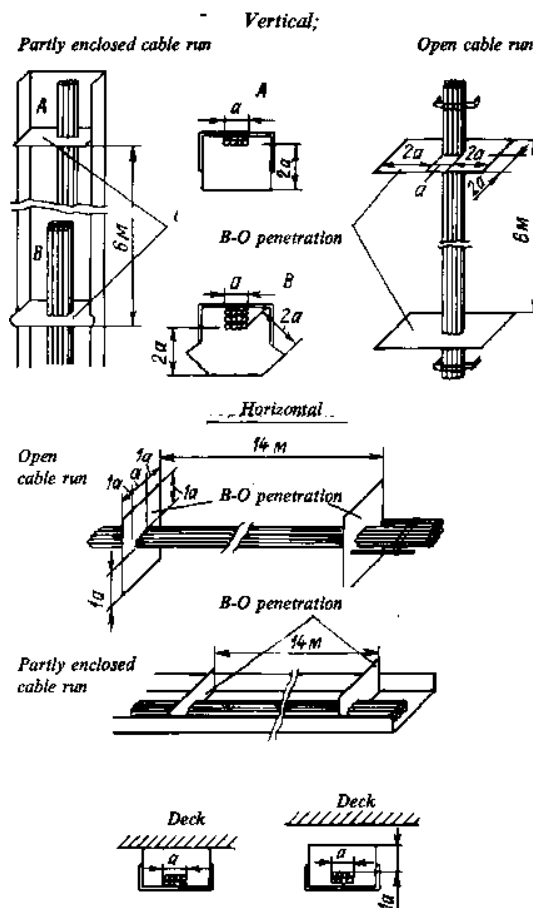

Fig. 16.8.4.3.2-2
Cable runs protection with B-O fire-retarding divisions

16.8.4.7 Laying of cables with insulation designed for different permissible temperatures in common cable runs shall be effected in such a way that the cables are not heated above the permissible temperature of the cables having a lesser permissible temperature.

16.8.4.8 Cables with different protective coverings the less durable of which may be damaged, shall not be laid in one common pipe, conduit or by the other way of joint not supported laying.

16.8.4.9 Cores of multi-core cables shall not be used for supply and control of essential services not associated with one another.

The multi-core cables shall not be used simultaneously for a safety voltage and working ones exceeding the safety level.

16.8.4.10 Where services are supplied with two separate feeders, these feeders shall be laid in different runs as far apart as practicable in the horizontal and vertical directions.

16.8.4.11 Where cables are laid in ducts or other structures made of combustible materials, the locations of cable laying shall be protected against ignition by means of suitable fire protection, such as lining, coating or impregnation.

16.8.4.12 The laid cables shall not be flushed into thermal or sound insulation if it is made of combustible materials. The cables shall be separated from such insulation with the non-combustible material lining or laid at a distance of at least 20 mm from it.

Where cables are laid in thermal or sound insulation made of non-combustible materials, the cables shall be designed for the relevant reduction of loading.

16.8.4.13 Cables laid in refrigerated spaces shall have the protective sheath of metal, polychloroprene rubber or other material resistant to the exposure to a coolant.

Where cables are provided with armour, the last shall be properly protected against corrosion.

16.8.4.14 Cables in refrigerated spaces shall be laid on perforated panels or bridges and fastened so as to provide a free space between the cables and space walls. The panels, bridges and cable clips shall be protected against corrosion.

Where cables cross the thermal insulation of a refrigerated space, they shall pass through it at a right angle in a suitable grommet sealed at both sides.

16.8.4.15 For cable laying, minimum internal bending radii shall be maintained in accordance with [Table 16.8.4.15](#).

Table 16.8.4.15

Cable type		External cable diameter, mm	Minimum bending radius of cable
Cable insulation material	Type of protective cable covering		
Rubber or polyvinylchloride	Armoured with metal tape or wire	Any	10d
	Metal sheath	Any	6d
	Lead alloy and armour	Any	6d
	Other coverings	Under 9,5	3d
		9,5 to 25,4	4d
Over 25,4	6d		
Varnished cambric	Any	Any	8d
Mineral insulation	Metal	Under 7,0	2d
Ethylene-propylene rubber or cross-linked polyethylene	Semiconducting and/or metal	7,0 to 12,7	3d
		Over 12,7	4d
		25 and over	10d

16.8.4.16 Cables and earthing jumpers of the equipment mounted on shock absorbers shall be terminated so as to prevent their damage in service.

16.8.4.17 Cables laid on open decks, masts etc. shall be protected against the direct exposure to sun radiation.

16.8.5 Cable fastening.

16.8.5.1 Cables shall be properly fastened with clips, staples, holders etc. made of metal, or non-combustible or flame-retardant material.

The fastener surface shall be wide enough and have no sharp edges. The fasteners shall be selected in such a way that the cables are securely fastened without damage to their protective coverings.

16.8.5.2 When cables are laid horizontally, spacings between cable fastening points shall not exceed the values given in [Table 16.8.5.2](#), and for vertical cable runs, they may be increased by 25 %.

Table 16.8.5.2

External cable diameter, mm		Spacing between cable fastening points for cables, mm		
Over	Under	Without armour	With armour	With mineral insulation
–	8	200	250	300
8	13	250	300	370
13	20	300	350	450
20	30	350	400	450
30	–	400	450	450

16.8.5.3 Cables shall be fastened so that mechanical strains in cables are not transmitted to their inlets and connections.

16.8.5.4 Cable runs and cables laid in parallel with the MODU shell plating shall be fastened to framing rather than to plating.

On watertight bulkheads and masts, cables shall be fastened on special structures (saddles, tray plates, chocks, etc.).

16.8.5.5 Cables running parallel to bulkheads subjected to sweating shall be laid on bridges or perforated panels so as to provide a space between the cables and bulkheads.

16.8.5.6 Cable runs shall be laid with a minimum number of crossings. Bridges shall be used where cables cross each other. An air gap of not less than 5 mm shall be left between the bridge and the cable run crossing it over.

16.8.6 Cables penetrating decks and bulkheads.

16.8.6.1 Cable penetrations through watertight, gastight and fire-resisting bulkheads and decks shall be sealed with appropriate devices.

Sealing where the cables penetrate through the above bulkheads and decks shall not impair their tightness; no forces resulting from elastic hull deformation shall be transmitted to the cables.

16.8.6.2 Where cables are laid through non-tight bulkheads or structural elements less than 6 mm thick, holes for cables penetration shall be fitted with linings and bushes to prevent damages to the cables.

No linings or bushes are required for bulkheads or framing 6 mm and over thick, but hole edges shall be rounded.

16.8.6.3 Cable laying through watertight decks shall be effected by one of the following ways:

.1 in metal pipes (risers) extended above the deck to a height not less than 900 mm in locations of potential mechanical damage to the cable, and to a height not less than that of the door coaming in the space where damage there is no risk of such;

.2 in common metal sockets or boxes with additional protection of cables with casings of the height specified in [16.8.6.3.1](#).

The boxes shall be filled with packing compound, while the pipes shall be provided with glands or be stuffed with cable compound.

16.8.6.4 Cable penetrations shall be tested for tightness in accordance with the requirements of Appendix 1 to Section 4, Part IV "Technical Supervision during Manufacture of Products" of the Rules TSDCS.

16.8.7 Packing compounds.

16.8.7.1 To fill the cable boxes in watertight bulkheads and decks, the use shall be made of packing compounds having good adhesion to the inside surfaces of cable boxes and cable sheaths, being resistant to water and petroleum products, not shrinking and not losing its tightness in continuous service under conditions specified in [2.1.1](#) and [2.1.2](#).

16.8.7.2 Packings of cable penetrations through fire-resisting bulkheads shall withstand the standard fire test specified for the given class of division in 2.1.2.6, Part VI "Fire Protection" of the RS Rules/C.

16.8.8 Cable laying in pipes and conduits.

16.8.8.1 Metallic pipes and conduits for cable laying shall be protected against corrosion on the inside and outside surfaces. The inside surface of pipes and conduits shall be even and smooth. Pipe and conduit ends shall be machined or protected so as to prevent their damage when cables are drawn in.

Cables with lead sheaths not having any additional protective covering shall not be laid in pipes and conduits.

16.8.8.2 The bending radius of a pipe and conduit shall be not less than that permissible for the largest diameter cable laid in them (refer to [16.8.4.15](#)).

16.8.8.3 The total cross-sectional area of all cables determined from their external diameters shall not exceed 40 % of the inside cross-sectional area of the pipe and conduit.

16.8.8.4 Pipes and conduits shall be mechanically and electrically continuous and securely earthed unless this earthing has not been effected while mounting the pipes and conduits.

16.8.8.5 Pipes and conduits shall be installed so as to prevent accumulation of water therein. Where required, ventilation holes shall be provided, as far as possible, in the highest and lowest points of the pipes and conduits so as to ensure air circulation and to prevent vapour condensation. The holes are permissible only in places where it will not enhance the danger of explosion or fire.

16.8.8.6 Cable pipes and conduits installed along the unit's hull and which can be damaged due to the hull deformation shall be fitted with compensating devices.

16.8.8.7 Where the use of cables with combustible covering is allowed according to [16.8.1.1](#), these cables shall be laid in metallic pipes.

16.8.8.8 Cables laid vertically in pipes and conduits shall be fastened so as to prevent their damage under the tension caused by their own mass.

16.8.9 Special precautions for single-core cables for alternating current wiring.

16.8.9.1 The use of single-core cables for alternating-current wiring is not recommended. Where it is necessary, the cables for circuits rated in excess of 20 A shall meet the following requirements:

- .1 the cables shall not have coverings of magnetic material;
- .2 the cables of one circuit shall be laid in one cable run or in one pipe. Laying of such cables in different pipes is allowed only when non-magnetic material pipes are used;
- .3 cable clamps, unless they are made of non-magnetic material, shall include all the single-core cables of one circuit;
- .4 the spacing between the cables shall be not more than one cable diameter.

16.8.9.2 The cables of one circuit shall be laid in one cable run or in one metallic pipe and shall be as short as practicable. It is allowed to lay such cables each under its non-magnetic screen (in a pipe) earthed at one point and isolated from other cable screens and from the hull.

16.8.9.3 Where single-core cables having a current rating over 250 A are laid parallel to steel structures, the spacing between the cables and these structures shall be not less than 50 mm.

16.8.9.4 When single-core cables of a conductor cross-section of 185 mm² or over are installed, a transposition (mutual position changing of cable line phases) of phases shall be effected at intervals not exceeding 15 m. Where cable length is below 30 m, no transposition is necessary.

16.8.9.5 Multicore cables with conductors in parallel shall be laid as single-core ones and all the requirements for single-core cables apply in this case.

16.8.10 Connection and tapping of cables.

16.8.10.1 The ends of rubber-insulated cables brought in machines, apparatus, switchgear and other equipment shall have contact, protective and sealing terminations which ensure a reliable electrical contact, prevent the penetration of moisture inside the cable, and also protect the insulation of cable cores against mechanical damage and effects of air and oil vapours.

16.8.10.2 Where rubber-insulated cable cores are connected, provision shall be made for insulation protection against damage (wear, etc.). Cable terminations and cable core connections shall be made so as to retain their electrical, mechanical and other characteristics after mounting and in service.

16.8.10.3 The protective covering of a cable inserted into a device shall enter not less than 10 mm inside.

16.8.10.4 Connection of cables where they are tapped shall be effected in branch boxes using standard clamps.

16.8.10.5 Where additional connections during cable laying are required, they shall be effected in suitable junction boxes provided with clamps. The joint as a whole shall be protected against ambient conditions. Other methods of cable connections approved by the Register may be applied.

17 ELECTRIC PROPULSION PLANTS OF SELF-PROPELLED MODU

17.1 APPLICATION AND DISTINGUISHING MARK IN THE CLASS NOTATION

17.1.1 The requirements of this Section cover electric propulsion plants and their components as well as their manufacture, installation and testing, including:

generators and their prime movers;

switchboards;

transformers/ reactors;

semiconductor frequency converters;

electric propulsion motors;

excitation systems;

electric propulsion plant control and monitoring (alarm systems, indication and logging systems) and safety systems;

wires, cables, busbars, trunking systems.

17.1.2 The requirements of this Section also cover bow and stern thrusters intended for MODU steering and dynamic positioning.

17.1.3 Compliance with this Section requirements and with applicable requirements of other Sections of this Part is mandatory for self-propelled MODU with the distinguishing mark **EPP** (Electric Propulsion Plant) added to the character of classification in accordance with 2.4.5 of Part I "Classification" of the MODU Rules.

17.1.4 The electrical equipment of the electric propulsion plant shall meet the requirements of other Sections and Chapters of this Part, unless otherwise specified in this Section.

17.1.5 In electric systems of electric propulsion plants, the voltage levels shall not exceed those specified in [18.1.2](#).

17.1.6 The complete set of documents both for the whole electric propulsion plant system and for all its main components (generators, transformers, propulsion motors, control systems, etc.) shall be submitted to the Register for consideration.

17.1.7 Each manufacturer of system components shall submit a confirmation substantiated by the documents proving that the produced electric propulsion plant component is in compliance with the requirements of international and national standards and corresponds to the Register regulations requirements.

17.2 TERMS AND DEFINITIONS

17.2.1 For the purpose of this Section, the following terms and definitions have been adopted.

Azimuth drive is a drive which moves the propulsion unit around the vertical axis.

Electric propulsion plant generator is a generator mainly used for power supply of the propulsion system.

Main control station of the electric propulsion plant is a control station of the main propulsion plant which is attended under seagoing conditions or when positioning.

Electric propulsion motor is an electric motor intended to provide propulsion power.

Double sensor is a sensor with two sensor elements in one housing.

Local control station is a control station located where a system is installed intended for selection and input of reference values for semiconductor frequency converters independent from reference values for remote control system and any external limitations.

Podded drive is a propulsion system in which the electric propulsion motor is located in a dedicated submerged unit (pod housing) of MODU.

Electric propulsion plant switchboard is a switchboard mainly used for power distribution to the propulsion systems.

Redundant sensor is two single sensors in separate housings for monitoring one and the same parameter.

Remote control system is a system which creates the reference values for the converters due to the control place selection and the limitations from other systems if any under normal condition.

Electric propulsion plant power management system is a control and safety system which provides the load depending starts and stops of the prime movers, the load sharing, etc.

17.3 CONFIGURATION OF ELECTRIC PROPULSION PLANT

17.3.1 Type systems.

17.3.1.1 The modern electric propulsion plant is designed, as a rule, with semiconductor converters and shall consist, at least, of the following components:

- main generators of the electric propulsion plant – 2 pcs;
- main switchboard divided into two sections by inter-sectional circuit breaker or other suitable disconnecting device – 1 pc;
- power transformers for conversion of the main switchboard voltage to that of semiconductor converters – 2 pcs;
- power semiconductor converters to supply the electric propulsion motor – 2 pcs;
- electric propulsion motor,
- microprocessor (computer) control and monitoring system.

17.3.1.2 For one propeller shaft electric propulsion plants, synchronous and induction main propulsion motors shall be equipped with two stator winding systems which can be independently disconnected from the relevant semiconductor frequency converter. Each converter shall be designed for at least 50 % rated power of the electric propulsion plant.

Propulsion DC motors shall be of the double-armature (double-commutator) type with each armature winding designed for at least 50 % of the rated power of the plant. Each armature winding shall be supplied from its independent converter. Any single failure in one converter shall not result in complete loss of power.

17.3.1.3 Provision shall be made for braking or locking devices for a propulsion shaft to prevent its free rotation with a switched-off propulsion motor (shaft) at any environmental conditions or during MODU towing.

17.3.1.4 The electric propulsion plant system design shall be based on the one failure principle, i. e. if any component of the electric propulsion plant fails, a MODU shall be underway at least at the partial power.

Provision shall be made for a warning alarm at all active control stations when any failure occurs in the electric propulsion plant system.

For all auxiliary machinery and essential services, provision shall be made for local control stations from where control is effected if any component of the remote automated control system of the electric propulsion plant fails.

17.3.1.5 If the electric propulsion plant is composed of components produced by different manufacturers, there shall be one named body responsible for the integration of the complete propulsion system.

This body shall distribute the priorities of all automated and automatic functions ensuring the safety of the entire MODU as it is provided by the control and monitoring computer systems software. This body shall have the necessary expertise and resources enabling a controlled integration process.

17.3.2 Torsional stress and torsional vibrations.

17.3.2.1 In order to prevent excessive torsional stresses and torsional vibrations of excessive magnitude, careful consideration shall be given to coordination of the moments of inertia and the elasticity constants of the entire propulsion system, and electrical characteristics in the system. The entire oscillating system may include not only prime movers, generators, electric motors, slip-couplings, gears, shafts and propellers, but also transformers, converters and exciters.

17.3.2.2 The manufacturers of the components shall provide all necessary information to the system responsible body, refer to [17.3.1.5](#).

The highest oscillating torque can be expected in case of two-phase short-circuit of the motor. The highest steady state torque can be expected in case of three-phase short-circuit of the motor. These possible load situations shall be under control of the electric propulsion plant power management system. Evidence shall be made by torsional vibration calculation.

17.3.3 Operational stability of electric propulsion plants.

The electric propulsion plant system shall be able to function reliably under all weather and manoeuvring (positioning) conditions.

Other onboard systems shall not influence the propulsion or manoeuvrability of MODU, e.g. common communication links, or common software in case of creating a common integrated control and monitoring system. Special consideration shall be given to electromagnetic interference, as specified in [2.2](#).

All control means for operating prime movers, set-up switches, contactors, excitation system switches, etc. shall be interlocked to prevent incorrect operation and damages to motors.

17.3.4 Protection against moisture and condensate.

17.3.4.1 Effective means shall be provided in electric propulsion motors, propulsion generators, semiconductor converters and other components of electric propulsion plants to prevent accumulation of moisture and condensate especially if they are idle for appreciable periods. These means can be, e.g. space heaters, air dryers, etc.

17.3.4.2 It is recommended to provide electric heating in the locations of electrical machinery, switchboards and control panels of the electric propulsion plant.

17.3.4.3 Stationary lighting shall be provided underneath the generators and motors of the electric propulsion plant.

17.3.4.4 Parts of electric propulsion machines (motors and generators) located under the floor shall meet a protection degree of at least IP56.

In case they are installed in a dry compartment or protected against the ingress of water by a watertight foundation, and, besides that, in case of a signal is provided to be activated upon water entering the compartment when water enters this compartment, IP23 degree of protection shall be met.

17.3.5 Excitation systems of electric propulsion plant components.

17.3.5.1 General requirements.

17.3.5.1.1 Every excitation system shall be supplied by a separate feeder. The obtainable current and voltage of the excitation system, as well as source of power shall fully comply with the requirements for all electric propulsion plant modes including manoeuvring, overcurrent and short circuit, as well as the capsizing moment conditions.

17.3.5.1.2 Supply circuits of excitation systems shall be protected against short circuits only, because the energy is consumed by the excitation winding which has constant electrical parameters strictly in accordance with the prescribed requirements. The activation of an electromagnetic release at short circuit shall be supplemented with an alarm at control stations.

17.3.5.1.3 If the built-in short-circuit monitoring device of the excitation system trips, the relevant circuit breaker of the generator or the motor shall also trip.

17.3.5.1.4 If the excitation system is fitted with independent safety devices against under-frequency and over-voltage or U/f-functions, they shall be adjusted in such a way that the system protection reacts first.

17.3.5.1.5 Excitation circuits shall be provided with means for suppressing voltage rise when an excitation switch is opened.

17.3.5.1.6 Special means shall be provided (filters, etc.) for limiting harmonic distortion and power factor reduction.

17.3.5.2 Generators excitation.

17.3.5.2.1 The steady and transient regulation conditions of the excitation system including the automatic voltage regulator shall be in accordance with IEC 60092-301.

17.3.5.2.2 Excitation systems shall be supplied from the generator, the generator shall be self-excited. The voltage built up shall be done automatically, without the aid of an external source of electrical power.

17.3.5.2.3 External source of electrical power may be used for exciter control circuits, as well as for initial excitation, provided it is redundant.

The external source of power shall be supplied from the main and emergency switchboards and, additionally, from the standby accumulator battery. At least two external sources of power for all electric propulsion plant generators shall be provided.

17.3.5.3 Electric propulsion motors excitation.

17.3.5.3.1 The exciter circuits shall be supplied directly from the same switchboard section supplying the stator windings.

17.3.5.3.2 Excitation systems and automatic monitoring systems shall be so designed that electric propulsion motors are protected from overspeeding in the event of the propeller breaking down or working clear of water.

17.4 BUSBAR SYSTEMS OF ELECTRIC PROPULSION PLANTS

17.4.1 Busbar systems for power transport shall be either certified for lifelong operation without service, or all mechanical and electrical joints shall be accessible for inspection and maintenance.

17.5 ELECTROMAGNETIC COMPATIBILITY OF ELECTRIC PROPULSION PLANTS

17.5.1 General.

The electric propulsion plant shall operate without malfunctions and failures being exposed to electromagnetic interferences, i. e. they shall comply with performance criterion A of IEC 61000 and the requirements specified in [2.2](#).

17.5.2 Total harmonic distortion.

17.5.2.1 Equipment producing transient voltage, frequency and current variations shall not to cause malfunctions and failures of other equipment on board, neither by conduction, induction nor radiation.

17.5.2.2 The design and manufacture shall take into account that power semiconductor converters of electric propulsion plant create electromagnetic interferences within the propulsion network. If propulsion network and electric power network are directly connected or by means of transformers, the total harmonic distortion (THD-) value of the voltage shall not exceed 10 %.

17.5.2.3 If a THD-value of 10 % is exceeded when operating the electric propulsion plant, the firm responsible for the design of electric propulsion plant shall ensure appropriate filtering and interference-free operation of any consumers.

17.5.3 Radio frequency interferences.

If semiconductor converters for electric propulsion plants are placed in separate rooms or cabinets, the maximum values for emissions are valid/measured only outside these rooms or cabinets.

The immunity requirements of the semiconductor converters of electric propulsion plant shall comply with at least the requirements for all other equipment on board the MODU.

Conducted and radiated emissions leaving the converter cabinet or room shall be reduced to a system-compatible level.

17.6 PRIME MOVERS OF ELECTRIC PROPULSION PLANT GENERATORS

17.6.1 General.

The prime movers driving the electric propulsion plant generators are the main engines of the MODU electric propulsion plant.

Note. Main engines shall comply with the specifications of the relevant parts of the MODU Rules.

17.6.2 Permissible speed deviations.

17.6.2.1 If the electric propulsion plant generators are also used for supplying the MODU power network, static and dynamic frequency deviations (in case of relevant load changes) shall meet the requirements for the power network specified in 2.11.3, Part IX "Machinery" of the RS Rules/C.

17.6.2.2 Where the speed control of the propeller requires speed variation of the prime mover of electric propulsion plant, the prime mover speed governor shall be provided with means for local and remote control.

17.6.2.3 The prime movers rated power and overload capacity shall be adequate to supply the power needed during transitional changes in operating conditions of the electrical equipment, as well as the electric propulsion plant load variations due to maneuvering, at sea, including severe weather conditions.

17.6.3 Parallel operation.

In case of parallel operation of generators, the control system used shall ensure stable proportional distribution of loads over the entire output range of the prime movers as specified in [3.2.2](#).

17.6.4 Reverse power.

17.6.4.1 When maneuvering from full ahead running to full speed astern the prime movers shall be capable of absorbing a proportion of the recuperated work without tripping due to overspeed or reverse power.

17.6.4.2 To absorb a proportion of the recuperated work and to retard the speed of the electric propulsion motor in reverse, braking resistors may be used ensuring the necessary limits on the prime movers and electrical machines speed. The amount of recuperated work shall be limited by the automated control system of the electric propulsion plant.

17.7 ELECTRIC PROPULSION PLANT GENERATORS

17.7.1 General.

17.7.1.1 Generators shall be designed and manufactured in accordance with the IEC 60034 series and IEC 60092-301 or equivalent national standards.

17.7.1.2 Generators operating with semiconductor converters shall be designed for the expected harmonics of the system.

A sufficient reserve shall be considered for the temperature rise, compared with sinusoidal load.

17.7.1.3 Stator windings of generators rated above 500 kVA shall be provided with temperature sensors.

17.7.1.4 Generators above 500 kVA shall be equipped with an electric heating designed to maintain the temperature inside the machine at about 3 °C above ambient temperature.

17.7.1.5 The electric propulsion plant generators shall be fitted with filters for cleaning a cooling air in open- and closed-circuit ventilation systems. Ventilation ducts shall be designed so as to prevent water ingress into the machine.

17.7.1.6 The electric propulsion plant generators may be used for supplying the auxiliary electrical machinery and services if they provide stable voltage and frequency in all operation modes, including manoeuvring modes, in compliance with the requirements of [2.1.3](#).

17.7.1.7 No circuit breakers shall be fitted in excitation circuits of generators except those which remove excitation of machinery at short circuits or damages in the main current circuit.

17.7.2 Generators bearing and lubrication.

17.7.2.1 Sliding bearing shells shall be easily replaceable. Provision shall be made for checking the bearing lubrication. Adequate lubrication shall be provided even at the maximum potential trim. Provision shall be made for relevant seals to prevent oil ingress inside the generator.

17.7.2.2 In case of bearings with forced lubrication (under pressure), the following alarms, as a minimum, shall be provided at electric propulsion plant control stations:

failure of lubricating system (failure of lubrication pump, loss of pressure in the lubrication pipe, etc.);

maximum temperature of each bearing.

17.7.2.3 All bearings shall be equipped with temperature sensors. Two-part bearings shall be fitted with thermometers indicating, wherever possible, the temperature of the lower bearing shell.

17.7.2.4 Generators shall be fitted with backup (emergency) devices for bearings lubrication which, in the event of malfunction or failure of the normal lubricating system, provide adequate lubrication until the machine full stop.

17.7.2.5 To avoid damage to bearings, provision shall be made to ensure that no harmful currents can flow between bearings and shaft, for which purpose one of the bearings shall be galvanically isolated from the machine casing.

17.7.3 Generators cooling.

17.7.3.1 The temperature of the cooling air of machines provided with forced air ventilation, air ducts, air filters and water coolers shall be continuously monitored by means of thermometers which are readable from outside the machine.

17.7.3.2 In addition to thermometers, temperature sensors of cooling air shall be provided which shall initiate an alarm with the excess of a permissible temperature.

17.7.3.3 For machines with a closed circuit cooling and heat exchanger, the flow of primary and secondary coolants shall be monitored. An alarm shall be initiated with the flow failure.

17.7.3.4 Leakage-water and condensed moisture shall be kept away from the machine windings. Provision shall be made for an alarm to monitor leakage.

17.7.4 Generators protection.

The protection shall be in accordance with IEC 60092-202 or relevant national standards.

The requirements specified in [8.2](#) and [18.2.4](#) (equipment with voltages higher than 1000 V) shall be met.

17.8 ELECTRIC PROPULSION PLANT SWITCHBOARDS

17.8.1 Electric propulsion plant switchboards shall meet the requirements of [4.5](#) (voltage of up to 1000 V) and [18.6](#) (voltage higher than 1000 V) and shall be designed like main switchboards.

The longitudinal segregation of the busbar, dividing it at least into two parts, shall be done by a load switch disconnecter or equal equipment.

17.8.2 When designing electric propulsion plant switchboards, selecting the bus cross-sectional area and etc., special consideration shall be given to the total harmonic distortion due to the presence of semiconductor converters, which increase heating, in the propulsion switchboards.

17.8.3 Where the definite sequence of switching operations shall be assured, provision shall be made for a reliable interlock to prevent wrong switching.

17.8.4 Switches for routine switching in deenergized circuits of the electric propulsion plant shall be provided with an interlocking device to prevent their tripping under voltage, or false switching.

17.9 ELECTRIC PROPULSION PLANT POWER TRANSFORMERS

17.9.1 General.

17.9.1.1 Transformers and reactors shall meet the requirements specified in [Section 11](#) and the requirements of [18.4](#) (high voltage transformers).

17.9.1.2 Special consideration shall be given to the total harmonic distortion associated with the use of power semiconductor converters.

17.9.1.3 At least two independent power transformers shall be installed in the electric propulsion plant.

Only transformers with separate windings shall be used. Auto transformers are only permitted for motor starting.

17.9.1.4 The winding temperatures of transformers used in electric propulsion plants shall be monitored with a sensor and indicator system.

17.9.2 Cooling.

17.9.2.1 Liquid cooled transformers.

Windings of liquid cooled transformers shall be completely covered by liquid, even for inclinations up to and including 22,5°.

Transformers shall be provided with the necessary collecting and accumulating arrangements for coolant leaks.

Fire detectors and fire-fighting equipment shall be installed in the vicinity of the transformer. The fire-fighting equipment may be manually operated.

Transformers shall be fitted with protection against gassing of coolant.

The coolant temperature shall be monitored with a sensor system. A pre-alarm shall be actuated before the maximum permissible temperature is attained. When the maximum permissible temperature limit is reached, a separate sensor shall activate protection which switches off the transformer.

The coolant level shall be monitored by two sensors, one of them shall actuate an alarm and the other set up to the maximum permissible level shall switch off the transformer.

17.9.2.2 Air cooled transformers.

The operation of fans for transformers cooling, as well as the cooling air temperature shall be monitored with a sensor system.

An alarm shall be given at the excess of temperature or fan failure.

17.9.2.3 Air forced/water forced cooled transformers.

Where a closed circuit cooling air system with an air cooler is used, in addition to the requirements of [17.9.2.2](#), the following shall be monitored:

the minimum flow of primary and secondary coolants (air and water);
heat exchanger leakage to be alarmed.

The heat exchanger shall be so installed that water leakages and condensed moisture are kept away from the windings.

17.9.3 Instrumentation for transformers.

Electric propulsion plant transformers shall be equipped with a three-phase ammeter on primary side.

17.9.4 Transformers protection.

Each electric propulsion plant transformer shall have overcurrent and short circuit protection on the primary and secondary side.

For protection on the secondary side, electric propulsion plant semiconductor converter may be used.

17.10 ELECTRIC PROPULSION PLANT SEMICONDUCTOR CONVERTERS

17.10.1 General.

17.10.1.1 Converters shall be designed in accordance with IEC 60146 series and requirements of [Section 12](#).

17.10.1.2 At least two entirely independent separate semiconductor converters shall be installed in the electric propulsion plant.

17.10.1.3 Common control of the converters is not permitted. This means, e.g. that two independent tachometer generators or one doubled tachometer generator shall be installed if a tachometer generator is needed for control system.

17.10.1.4 Two galvanically isolated actual speed sensors shall be provided for each control system. Common housing of both sensors is permitted.

17.10.1.5 If the converter feeds a permanently excited electric propulsion motor, a switch disconnecter shall be fitted in the "motor-converter" line which opens automatically in case of an inverter (rectifier) fault. Devices shall be provided for such fault diagnosis.

17.10.2 Design of semiconductor converters.

17.10.2.1 Semiconductor converters as well as the main current circuit equipment shall carry overcurrents not less than maximum permissible overcurrent for electric propulsion motors within the period specified for them.

17.10.2.2 Electric propulsion plant converters shall be designed for the nominal torque of the drive (nominal torque at a propeller shaft). Short-term overloads and speed variations (dips) resulting from overloads shall not lead to the activation of converter protection and failure of power management system.

17.10.2.3 The cabinets for semiconductor converters shall meet the standards of the main switchboard.

17.10.2.4 The design of cabinets for semiconductor converters shall provide the quick exchange of power components. This can be achieved by the use of modular design for separate thyristors, sub-modular design of one-phase thyristor or by other means.

17.10.3 Cooling of semiconductor converters.

17.10.3.1 If semiconductor converters are fitted with forced-cooling system, means for its monitoring shall be provided. In case of a cooling system failure, measures shall be taken to prevent overheating and damage to the converter.

17.10.3.2 An alarm system shall be provided for cooling systems. The alarm signal can be generated by the failure of coolant flow, or by a high temperature of the semiconductors.

17.10.3.3 Single failures in the converter cooling systems shall not result in tripping all converters of the electric propulsion plant.

17.10.4 Protection of semiconductor converters.

17.10.4.1 Operational overvoltages in a supply system of converters shall be limited by suitable devices to prevent damage (breakdown) of power semiconductor elements (thyristors and transistors).

17.10.4.2 A suitable power management system shall ensure that the rated current of semiconductor elements cannot be exceeded in all operating conditions, including the most severe ones.

17.10.4.3 Power semiconductors shall not be damaged by direct short circuit at the terminals. Protection by fuses against short-circuit currents is permitted. The relevant feedbacks of the converter shall control (limit) the current in such a way, that no components are damaged when the converter is switched on to a blocked motor.

17.11 HARMONIC FILTERING

17.11.1 Line filters shall be used to ensure the required harmonic distortion on the main switchboard busbars at any step of propulsion.

17.11.2 Each individual filter circuits shall be protected against overcurrents and short-circuit currents. The fuses in filter circuits shall be monitored. Any fuse burnout shall be alarmed.

17.11.3 When designing and using line filters, their layout shall be designed for any conceivable line constellations. In particular, self-resonance shall be excluded under any load conditions and operating generators constellations.

17.11.4 In case of several parallel filter circuits, the current symmetry shall be monitored. An asymmetrical current distribution in the individual filter circuits and the failure of one filter shall be alarmed.

17.12 ELECTRIC PROPULSION MOTORS

17.12.1 General.

17.12.1.1 For electric propulsion motors, the requirements of IEC 60034 and IEC 60092-301 shall apply, as well as equivalent national standards.

17.12.1.2 Stator windings of AC motors and interpole, mainpole and compensation windings of DC motors of electric machines with a capacity above 500 kVA, shall be provided with temperature sensors.

17.12.1.3 Motors operating with semiconductor converters shall be designed for the expected harmonics of the system. A sufficient reserve shall be considered for the temperature rise, compared with sinusoidal load.

17.12.1.4 Propulsion motors shall be fitted with an electric heating designed to maintain the temperature inside the machine casing at about 2 °C above ambient temperature.

17.12.2 Bearing and lubrication.

17.12.2.1 Shells of sleeve bearings shall be easily replaceable. Provision shall be made for checking the bearing lubrication. Adequate lubrication shall be assured even in inclined positions. Adequate sealing shall be provided to prevent ingress of oil into the motor.

17.12.2.2 In case of bearings with forced lubrication (lubrication under pressure), at least the alarm signals shall be provided at the propulsion plant stations:

in case of the oil supply failure (loss of oil pump, loss of pressure in the bearing supply pipe, etc.);

in case of attainment of excessive bearing temperature.

17.12.2.3 A circulatory pressure lubrication system for the bearings of electric propulsion machinery shall have two lubricating pumps, each with a capacity sufficient to ensure normal operating conditions of the electric propulsion motor.

17.12.2.4 All bearings shall be equipped with temperature indicators. Two-part bearings shall be fitted with thermometers indicating, wherever possible, the temperature of the lower bearing shell.

17.12.2.5 Propulsion motors shall be equipped with reserve (emergency) devices which, in the event of a failure of the normal lubricating oil supply, provide adequate lubrication until the machine has come to standstill.

17.12.2.6 To avoid damage to bearings, it is essential to ensure that no harmful currents can flow between bearings and shaft.

17.12.3 Electric propulsion motors cooling.

17.12.3.1 The cooling system shall ensure sufficient cooling under all load and speed conditions.

17.12.3.2 The temperature of the cooling air of machines provided with forced air ventilation, air ducts, air filters and water coolers shall be continuously monitored by means of thermometers which are readable from outside the machine.

17.12.3.3 Electric propulsion motors shall be fitted with built-in temperature sensors which shall give an alarm signal with the excess of a permissible temperature.

17.12.3.4 For machines with a closed circuit cooling system and a heat exchanger, the flow of primary and secondary coolants shall be monitored.

17.12.3.5 Provision shall be made to alarm leakage. The heat exchanger shall be installed so that water leakages and condensed moisture are kept away from the windings.

17.12.3.6 If the cooling system of the propulsion motor fails, the emergency operation mode to ensure MODU manoeuvring under heavy navigating conditions shall be provided. Interventions by an operator for opening of emergency air flaps are permitted.

17.12.3.7 Air-cooled electric propulsion motors shall be fitted with two forced-air fans, each having a capacity sufficient for normal operation of the electric motor. A visual alarm indicating fans operation and an alarm on their shutdown shall be provided.

17.12.3.8 A liquid cooling system for multiarmature machines shall be independent for each armature.

17.12.4 Protection of electric propulsion motor.

17.12.4.1 Overcurrent protective devices in the main and excitation circuits shall be set sufficiently high so that there is no possibility of their operating due to the overcurrents caused by manoeuvring or normal operation in heavy seas.

17.12.4.2 Short-circuit and over-current protection may be provided by the converter. Different electric propulsion motor designs (DC, synchronous, induction and permanent-magnet excitation motors) shall be taken into consideration.

17.12.4.3 Provision shall be made for an independent overspeed (runaway) protection device as required in 2.11, Part IX "Machinery" of the MODU Rules.

The electric propulsion motor shall be capable to withstand overspeed up to the limit reached in accordance with the characteristics of the overspeed protection device at its specified operational setting.

17.12.4.4 A motor shall be capable to withstand a sudden short-circuit at its terminals under rated conditions without suffering damage.

Steady state short-circuit current of permanent excited motors shall not cause thermal damages of the motor windings and the current carrying components, slip rings, cables, feeders or busbars.

17.12.5 Accessibility and facilities for repairs in situ.

17.12.5.1 For purposes of inspection and repair, provision shall be made for access to the stator and rotor coils, and for the withdrawal and replacement of field coils.

17.12.5.2 Facilities shall be provided for supporting the shaft to permit inspection, withdrawal and replacement of bearings.

17.12.5.3 Adequate access shall be provided to permit resurfacing of commutators and slip-rings, as well as the renewal and bedding of brushes, rotating rectifiers and protection equipment, if any.

17.13 SPECIAL REQUIREMENTS FOR PODDED DRIVES

17.13.1 General.

17.13.1.1 If the space, where an electrical machine and other equipment are located, is inaccessible during operation and associated with special environmental conditions (high temperature, humidity, etc.), special measures shall be taken like use of highly reliable materials and components, adequate number of sensors, as well as special means for protection of propulsion motor against flooding and damages.

The components, e.g. controls, sensors, slip rings, cable connections and auxiliary drives shall withstand undamaged the strength of vibration, of at least 4g from 3 Hz to 100 Hz.

17.13.2 Sensors.

17.13.2.1 The manufacturer shall prepare a list of all sensors with type, location of their installation, task and values (range and set points).

17.13.2.2 Important operational values for maintaining the drive and control ability in inaccessible areas shall be recorded, evaluated and shown redundantly by alarm and indicator systems.

17.13.2.3 The recorded results shall be checked for plausibility. Implausible input signals shall trigger an alarm. Only self-checking sensors shall be used.

17.13.2.4 Sensors which can only be changed during dry docking shall at least be constructed as double sensors, i. e. with two sensors in one housing.

17.13.3 Bearings.

17.13.3.1 Oil filling levels in bearing housings shall be monitored during operation and standstill. Any oil leakage shall activate an alarm.

This applies to circulated lubrication systems as well. These systems shall additionally be equipped with lubricating oil flow monitoring. A flow level monitoring alarm shall be independent from the electric propulsion plant power management system.

17.13.3.2 Shaft bearings shall be monitored on inadmissible changes during operation, e.g. by analysis of temperatures, vibrations and oil quality.

The temperature of shaft bearings shall be monitored by an alarm and protection system. The alarm shall be carried out in two steps: alarm and engine stop. The protection system shall be independent from the temperature indication system for shaft bearings, and the alarm system.

17.13.4 Bilges in pod housings.

17.13.4.1 The bilge level shall be monitored. In addition to the conventional bilge sensors (high level, HL), independent sensors (high high level, HHL) shall be provided which stop the podded drives automatically and protect it from consequential damages.

17.13.4.2 In case the connecting component between the pod housing of electric propulsion motor and the MODU hull is a separated room and not connected to the engine bilge, a level monitoring shall be provided.

17.13.4.3 The shaft sealing system shall be monitored in a way that ingress of sea water is ascertained before consequential damage appears. An emergency shaft sealing system shall be provided. The function of the activation system shall be checkable, e.g. with compressed air up to the last valve.

17.13.5 Fire detection system in a pod housing.

An effective fire detection system with the adequate number of sensors of the relevant type shall be provided. The general requirements for such systems are specified in [7.5](#).

17.13.6 Accessible spaces in a pod housing.

Sufficient illumination and ventilation shall be provided for accessible spaces of the pod housing where regular maintenance work and equipment inspection are carried out. Entries to these areas shall be locked in such a way that access is only possible, if the personnel cannot be endangered by the drives of the electrical equipment and machinery installed there.

17.13.7 Protection of the propulsion motor.

17.13.7.1 Motors of more than 1 MW and all permanent excited motors shall be provided with protection against internal faults that also monitors the connections between the semiconductor converter and the motor. The power supply to the defective equipment shall be interrupted with an appropriate time delay and an alarm shall be given.

17.13.7.2 Humidity shall be monitored for motors with closed air cooling systems. The excess of the permissible humidity level shall be alarmed.

17.13.8 Motor supply lines.

17.13.8.1 Cables operated at high temperature limits shall be installed separate from other cables. If required, splitters shall be provided to prevent contacts between cable sheaths.

17.13.8.2 Test reports of temperature rise tests of busbars with increased current density or cables operated at high conductor temperature values shall be submitted.

17.13.8.3 During the temperature rise test at the sea trial, it shall be proven that the permitted maximum temperature values in the area of the terminals are not exceeded.

17.13.8.4 IP protection for all terminals, cable glands and busbar connections shall be equal to motor protection, however, at least IP44. These requirements are also valid for control cables.

17.13.9 Slip rings.

17.13.9.1 It shall be taken into account that the mechanical and electrical characteristics of the slip rings can be degraded by contamination with oil, carbon dust and salt-mist air, or by oxidation. In this connection, a suitable reserve shall be provided for the commutated current and operational voltage.

17.13.9.2 A temperature-rise test of the slip ring shall be carried out as a type test. The suitability of used materials at maximum permitted temperature values shall be proven.

17.13.9.3 The permitted conductor temperature values of the connected cables shall not be exceeded. During the temperature rise test at the sea trial it shall be proven, that the permitted temperature limits of all slip rings components are not exceeded.

17.13.9.4 Where data from feedback sensors, controlled variable sensors, etc. are transmitted via a data bus of slip rings, the busbar shall be duplicated. Failure of each single busbar shall be alarmed.

17.13.9.5 Slip rings unit fitted with external forced cooling system shall be capable of operation without a cooling system for a certain period of time. The cooling system failure shall be alarmed.

17.13.10 Azimuth drive.

17.13.10.1 Azimuth drive shall meet the requirements for steering gear in accordance with [5.10](#). Single failure localization principle shall be ensured for all electrical and hydraulic components. MODU safe operation shall be ensured independently of the rudder angle and MODU speed at any time a failure occurs. For these purposes a Failure Mode Effect Analysis (FMEA) shall be developed and submitted for agreement by a designer.

17.13.10.2 The position of the azimuth drive shall be mechanically indicated on a scale at the drive location (steering compartment).

17.13.10.3 At least two independent azimuth electric drives shall be provided for each azimuthal unit for turn, whereby one drive shall be supplied from the main switchboard and the other, from the emergency switchboard.

17.13.10.4 Azimuth electric drives shall be protected against overcurrent (only by semiconductor converter control system) and short-circuit. They shall be able to supply 160 % of the torque necessary for the rated speed of movement for 60 sec, as specified in 6.2.2, Part IX "Machinery" of the RS Rules/C.

Azimuth drives with different design, e.g. hydraulic systems, shall also be able to fulfil these requirements.

17.13.10.5 The thrust azimuth angle shall be limited to $\pm 35^\circ$. At low propulsion power rating, low MODU speed or crash-stop manoeuvre these limits may be disabled with the power management system.

17.13.10.6 The thrust azimuth angle shall be limited related to the steps of propulsion that MODU safety is not endangered (due to excessive thrust during the turn). The system of such limitations (interlock) shall be provided redundantly and independently of the control of the azimuth angle (pod housing thrust).

17.13.10.7 Reaching or exceeding the permissible limitations of the azimuth angle shall be alarmed. After triggering the limitation, it shall be possible to move the azimuth drive back to the permitted angles of the drive turn without manual reset.

17.13.10.8 The operation and indication equipment of the azimuth drive shall be arranged in such a way that the set direction of the propeller thrust or the direction of the MODU moving is clearly indicated. It shall be clear to the operator whether the direction of the MODU moving or the direction of the propeller thrust of the electric propulsion plant was chosen.

17.13.10.9 The local control station for azimuthal unit shall be equipped with the following:

- ammeters for each supply system of each load component;
- azimuth angle (turn angle) indicators for each drive;
- power supply system readiness for operation indicators for each drive;
- power supply system disturbance indicators for each drive;
- and provide for the following:
 - power limitation (from converter);
 - control from the main machinery control room;
 - control from the navigating bridge;
 - control from local control station;
 - running indication for the associated propulsion drive.

The local control station can be activated locally at any time and shall have the highest priority.

17.14 POWER MANAGEMENT SYSTEMS OF THE ELECTRIC PROPULSION PLANT

Computer based power management systems of the electric propulsion plant shall be designed and tested in compliance with the requirements of Section 5, Part XIV "Automation" the MODU Rules.

17.14.1 Power management systems of electric power plant.

17.14.1.1 For power supply systems of electric propulsion plants with generators operating in parallel, the automated power management system shall be provided which will ensure adequate power generation being consistent with the needs of specific operational modes of the electric propulsion plant, in transit/maneuver including. Automatic load based disconnection of generators in maneuver mode is not permitted.

17.14.1.2 In case of under-frequency on main switchboard busbars, overcurrent or overload and reverse power, the propulsion power shall be automatically limited (to prevent de-energizing of main switchboard busbars).

17.14.1.3 If generators are running in parallel and one of them is tripping by protection system, the automated power management system shall automatically reduce the electric propulsion plant load to protect the remaining generators against unacceptable overloads and ensure their operation at permissible loads. The same requirement applies to the main switchboard busbars tiebreakers.

17.14.1.4 Tripping of the main switchboard busbars tiebreaker shall not lead to any malfunction of the system. It is not necessary that the power management system remains in the automatic mode if the power supply system is split. Any loss of the power management system automatic functions shall be alarmed.

17.14.2 Typical configuration of electric propulsion plant and control stations.

17.14.2.1 The minimal configuration consists of the following components:

- one electric propulsion control station on the navigating bridge;
- one central processing unit (microcontrollers) in the engine room;
- two semiconductor converters;
- one electric propulsion motor (two independent stator winding systems);
- one local control panel (two independent reference inputs);
- one telegraph receiver.

17.14.2.2 As option the wing control and the engine control room (ECR) control can be provided (with engine telegraph station).

Control shall be possible if the control system failed, therefore the local control panel shall be installed close to the converters and shall be directly connected to the converters by control circuits.

Local engine telegraph station shall be provided there.

17.14.3 Location of the electric propulsion plant control stations.

17.14.3.1 Electric propulsion plant control stations may be located at any convenient place according to the MODU purpose.

Where control stations are arranged outside the machinery space, i.e. on the bridge or in other locations, control stations in the machinery space or main machinery control room shall be provided as well.

17.14.3.2 The local control station has a priority and shall be located in the vicinity of the drive or semiconductor converters. Changes of electric propulsion plant modes generated at this station shall be displayed by the system indicating a preset and executed commands.

Where several control stations are available, a control stations switch in the control station having a priority shall be provided. Such switch shall provide switching of any, but only one control station (central and wing stations on the navigating bridge are considered as one control station).

17.14.3.3 Each control station shall have an emergency stop device independent of the control system and the active (in "ON" condition) control station.

17.14.4 Main and local control station.

17.14.4.1 At least two mutually independent main and local control stations of the electric propulsion plant shall be provided.

17.14.4.2 In case of damage, malfunctioning or loss of power supply of the main station control system, a local control of the electric propulsion plant converters shall be provided.

17.14.4.3 The electric propulsion plant main control station shall be fitted with systems such that the steering (azimuth thrust change) control system can operate independently of the electric propulsion motor speed and reverse control system.

17.14.4.4 All electric propulsion plant alarms shall be acknowledged at the local control station. Alarms which do not require any further intervention of the personnel can be acknowledged at the main control station (on the navigating bridge) with the mandatory follow-up acknowledgement at the local control station.

17.14.4.5 Restart of the electric propulsion plant shall be possible from both (main and local) control stations, depending on which one has been preselected. After the main switchboard de-energizing it shall be possible to restart the electric propulsion plant at the main control station.

17.14.4.6 If the electric propulsion plant is controlled from a panel or desk with the use of electric, pneumatic or hydraulic drive, the failure of them shall not result in electric propulsion plant tripping, and each control station at the panel or desk shall be immediately ready for manual operation.

17.14.4.7 Mechanically linked control stations installed in the wheelhouse (on the navigating bridge) for their synchronous operation may be permitted.

17.14.4.8 The control system of the electric propulsion plant shall be so designed that no time delay is needed for the personnel to move a control handle at a control station to a new position.

17.14.4.9 The electric propulsion plant control system shall be provided with an interlock to prevent the electric propulsion plant activation with a shaft turning gear engaged.

17.14.4.10 Each control station shall have a visual indication on the control circuit is energised or not.

17.14.5 Measuring, indicating and monitoring equipment.

17.14.5.1 Failures in measuring, monitoring and indicating equipment shall not cause a failure of the electric propulsion plant control system, e. g. failure of the actual value (speed) sensor or of the reference speed value sensor shall not cause an excessive increase of propeller speed.

17.14.5.2 The local (active) control station shall be equipped with the following:
ammeter for each power supply line of each load component (stator current of each winding, etc.), and also in the excitation circuit (for adjustable- excitation systems);
voltmeters for each power supply line current of each load component, and also for power supply of the excitation system (for adjustable-excitation systems);
speed indicator for each shaft;
"Powerplant ready for electric propulsion plant operation" indicator;
"Powerplant disturbed" indicator;
"Electric propulsion plant power limited" (from converter) indicator;
"Control from the main machinery control room" indicator;
"Control from the navigating bridge" indicator;
"Control from the local control station" indicator.

17.14.5.3 The main control station (on navigating bridge) shall be equipped with the following:

speed indicator for each shaft;
shaft power meter for each shaft;
"Powerplant ready for switching on" (for additional generators) indicator;
"Power plant ready for electric propulsion plant operation" indicator;

"Power plant disturbed" indicator;
"Electric propulsion plant power limited" indicator;
"Request to reduce power" indicator – if not automatically controlled or "override" button pushed (cancellation of the power plant automated control);
"Control from the main machinery control room" indicator;
"Control from the navigating bridge" indicator;
"Control from the local control station" indicator;
indication of the generators operating at the electric propulsion plant;
indication of power reserve (recommended).

17.14.5.4 When two or more control stations are provided for change of speed and angle of turn of controllable pitch propeller (CPP) blades, both speed change and angle of turn of CPP blades indicators shall be provided at each control station.

17.14.5.5 The main machinery control room shall be equipped with the following:
speed indicator for each shaft;
shaft power meter for each shaft;
"Powerplant ready for switching on" (additional generators) indicator;
"Power plant ready for electric propulsion plant operation" indicator;
"Power plant disturbed" indicator;
"Electric propulsion plant power limited" indicator;
"Request to reduce power" indicator – if not automatically controlled or "override" button pushed (cancellation of the power plant automated control);
"Control from the main machinery control room" indicator;
"Control from the local control station" indicator;
"Control from the navigating bridge" indicator;
indication of the generators operating at the electric propulsion plant.

The list of parameters controlled by the alarm system is given in Appendix.

17.14.6 Availability (fail-safety).

17.14.6.1 The loss of power or malfunctioning of any other control and monitoring systems shall not result in loss of electric propulsion plant control, MODU steering or azimuth drive.

17.14.6.2 Electric propulsion plant, azimuth drives and their control systems shall have self-check system and an alarm system to detect failures quickly.

17.14.6.3 The most probable failures, e. g. loss of power, wire failure or cable and wire short circuits, etc. shall result in the least critical of all possible new conditions (fail to safety).

18 REQUIREMENTS FOR ELECTRICAL EQUIPMENT DESIGNED FOR VOLTAGE IN EXCESS OF 1 KV UP TO 15 KV

18.1 GENERAL

18.1.1 Application.

These requirements apply to three-phase alternating current systems with rated voltages in excess of 1 kV, where rated voltage means the voltage between phases.

The requirements for design and installation of low voltage electrical equipment (up to 1000 V) set out in this Section also apply to high voltage electrical equipment, if not otherwise stated in the present section.

Additional requirements for electrical equipment designed for a voltage in excess of 15 kV are specified in Section 19, Part XI "Electrical Equipment" of the RS Rules/C.

18.1.2 Nominal system voltage.

18.1.2.1 The nominal voltage of the electrical power distribution system shall not exceed values specified in [Table 18.1.2.1](#).

Table 18.1.2.1

Rated interphase voltage, kV	Rated frequency, Hz
3 (3,3)	50 (60)
6 (6,6)	50 (60)
10(11)	50 (60)
15	50 (60)

Note. Where necessary for special application, voltage higher than 15 kV may be accepted.

18.1.3 High-voltage, low-voltage segregation.

18.1.3.1 Electrical equipment with a voltage over 1000 V shall not be installed in the same casing (enclosure) with low-voltage equipment unless the relevant segregation is provided or appropriate measures ensuring safe access to low-voltage equipment maintenance are taken.

18.1.3.2 Insulating materials used for electrical equipment shall ensure the insulation resistance of 1500 ohms per 1 V rated voltage, but not less than 2 megohms during continuous operation of the unit.

18.1.3.3 At the entrance to special electrical rooms, a warning notice shall be provided indicating the voltage. Enclosures of electrical equipment installed outside special electrical rooms shall be provided with warning notices indicating the voltage.

18.2 SYSTEM DESIGN

18.2.1 Distribution systems.

The following power distribution systems may be used for high-voltage alternating three-phase current plants:

insulated three-wire system;

three-wire system with the neutral earthed to the MODU or FOP hull through a high-value resistor or reactor;

four-wire system with directly earthed neutral.

18.2.1.1 Configuration of network for ensuring uninterruptible power supply.

The main switchboard design shall provide for the possibility of its separation into, as a minimum, two independent parts of sections by means of a circuit breaker or disconnecter.

Each part of sections shall be connected to, as a minimum, one generator.

Where two independent main switchboards interconnected by cable jumpers are provided, circuit breakers shall be fitted at its both sides. All the duplicated electrical drives shall be supplied from different main switchboards or its split sections.

18.2.1.2 Earthed neutral systems.

18.2.1.2.1 Neutral points of generators running in parallel may be connected to the common busbar before an earthing resistor or reactor fitted in the switchboard or directly at the generator.

18.2.1.2.2 In case of an earth fault, the leakage current shall not exceed the rated current of the largest generator or the total rated current of a relevant main switchboard section and shall not be less than the triple minimum current required for earth-fault protection activation.

18.2.1.2.3 When the system is energized, at least one neutral earthing point shall be closed. The electrical equipment in systems with a directly earthed neutral connected to the hull through a high capacity resistor or reactor shall withstand without damage the single phase-to-earth fault current during the time necessary for protection device activation.

18.2.1.3 Neutral disconnection.

In the neutral wire of each generator, provision shall be made for a disconnecter, which may cut out the neutral from earthing for insulation resistance measurements and generator maintenance.

18.2.1.4 Hull connection of earthing impedance.

18.2.1.4.1 All earthing impedances of neutral points shall be connected to the hull. The connection to the hull shall be so arranged that any circulating currents in the earth connections do not interfere with radio, radar, internal communication and control equipment circuits.

18.2.1.4.2 It is permitted to connect all resistors or reactors to the common earthing busbar, which shall be connected to the unit hull at least at two points.

18.2.1.5 Divided systems.

Neutral connections to the hull shall be provided for each split group of main switchboard sections in divided systems with an earthed neutral.

18.2.2 Degrees of enclosures protection.

18.2.2.1 General requirements.

Each part of electrical equipment shall have shielded enclosures with degree of protection corresponding to its location and effecting environmental conditions. The requirements of IEC Standard 60092-201 may be considered as minimum.

18.2.2.2 Electrical machines.

A degree of protection by enclosure for electrical machines shall be at least IP23. The degree of protection of machines lead boxes shall not be less than IP44.

Motors installed in spaces accessible to unqualified personnel shall have the degree of protection of at least IP4X to prevent touching of live and rotating parts.

18.2.2.3 Transformers.

A degree of protection by enclosure for transformers shall be at least IP23.

Transformers installed in spaces accessible to unqualified personnel shall have the degree of protection of at least IP4X.

The requirements of [18.7.1](#) apply to transformers having no enclosure.

18.2.2.4 Distribution switchboard, controlgear (control panels) and converters.

The degree of protection of metal enclosed switchboards, controlgears and static converters shall be at least IP32. For switchboards, controlgears and static converters installed in spaces accessible to unqualified personnel, a degree of protection of at least IP4X is required.

18.2.3 Insulation distances.

18.2.3.1 Air clearance.

The air clearances between live parts with different potentials or between live parts and earthed metal parts or the casing shall be not less than specified in [Table 18.2.3.1](#).

Table 18.2.3.1

Nominal voltage (kV)	Minimum air clearance (mm)
3 (3.3)	55
6(6.6)	90
10 (11)	120
15	160

Minimum clearances for intermediate values of working voltages are assumed as for the next larger value of a standard voltage.

Selecting lesser clearance, special high-voltage impulse tests shall be made to confirm admissibility of such clearance selected.

18.2.3.2 Creepage distances.

Creepage distances between live parts under different potentials and between live parts and hull shall be selected in accordance with relevant national or international standards.

For non-standardized parts within the busbar section of a distribution switchboard, the minimum creepage distance shall be at least 25 mm/kV and behind current limiting devices, 16 mm/kV.

18.2.4 Protective devices.

18.2.4.1 Faults on the generator side.

In addition to the types of protection specified in [8.2](#), generators shall be provided with protective devices against a phase-to-phase fault in the cables connecting the generator and main switchboard, and against turn-to-turn faults inside the generator.

When this protective device is activated, the generator shall be shut off from the main switchboard and its excitations shall automatically be removed.

In distribution systems with dead earthed neutral, the earth fault of a generator phase shall also result in the activation of protection.

18.2.4.2 Faults to earth.

18.2.4.2.1 An audible and visual alarm shall be activated in a system (control panels) at any earth faults.

18.2.4.2.2 Protection automatically disconnecting a faulted circuit at earth faults shall be activated in low-impedance (deadly-earthed) systems.

18.2.4.2.3 In high-impedance earthed systems (systems with a neutral earthed through a high-value resistor), where the feeders outgoing from the main switchboard cannot be disconnected at an earth fault, the insulation of electrical equipment supplied from these feeders shall be designed for the line voltage of the system.

Notes: 1. The system to be classified as effectively earthed (low impedance) if a coefficient of earthing is below 0,8, and ineffectively earthed (high impedance), 0,8 and over.

2. The efficient of earthing means a ratio between a voltage "phase-to-earth" in a healthy, i.e. intact system, and a line ("phase-to-phase") voltage.

18.2.4.3 Power transformers.

Power transformers shall be protected against a short circuit and overloading with circuit breakers.

Where the transformers are intended for running in parallel, the activation of protection on the primary side shall cause their automatic disconnection on the secondary side as well.

18.2.4.4 Voltage transformers for control systems and instruments.

Transformers intended for supply of control circuits and instruments shall be protected against overloading and short circuits on the secondary side.

18.2.4.5 Fuses.

Fuses shall be used for short circuit protection.

Fuses shall not be used for overload protection.

18.2.4.6 Low-voltage systems.

Low-voltage distribution systems (up to 1 kV) supplied from high-voltage transformers (systems) shall be protected against overvoltages associated with the ingress of a high voltage on the secondary (low voltage) side. This may be achieved by:

earthing of the low-voltage system;

appropriate neutral-voltage limiters;

earthed screen between the primary and secondary windings of the transformer.

18.2.4.7 Protective earthing.

Metal enclosures of electrical equipment shall be earthed with external copper flexible conductors having a cross-sectional area designed for a single-phase short-circuit current, but not less than 16 mm². Earthing wires shall be suitably marked.

Earthing conductors may be connected by welding or with bolts not less than 10 mm in diameter.

18.3 ROTATING ELECTRICAL MACHINES (DESIGN REQUIREMENTS)

18.3.1 Stator windings of generators.

Generator stator windings shall have accessible both phase and neutral ends to ensure the installation of the differential protection.

18.3.2 Temperature detectors.

Rotating electrical machines shall be provided with temperature detectors embedded in their stator windings to actuate a visual and audible alarm whenever the temperature exceeds the permissible limit.

If embedded temperature detectors are used, means shall be provided to protect the measuring circuit against overvoltage.

18.3.3 Tests.

In addition to the tests normally required for every rotating electrical machine, a high voltage test in accordance with IEC Standard 60034-15 shall be carried out on the individual phase windings (coils) to demonstrate a satisfactory level of resistance to the turn-to-turn short circuits caused by steep-fronted voltage surges.

18.3.4 Design.

18.3.4.1 The machine casing, end shields, protective guards of air intakes and outlets shall be made of steel alloys. Aluminium alloys for the above machine components are not permitted.

18.3.4.2 A draining arrangement, readily accessible for maintenance, shall be provided in the lower part of the machine housing for removal of condensate.

The rigidly secured canopy preventing ingress of water and other foreign objects into the machine shall be fitted on the top of vertical designed motors. The lower end shield shall be shaped so as to prevent accumulation of water in way of a bearing.

18.3.4.3 The terminal boxes of machines shall be dimensioned so as to ensure:
necessary insulation distances between current-carrying parts and the casing;
necessary insulation distances between phases;
sufficient space for arrangement of connecting cable terminations and windings ends; and
the opportunity to change the arrangement of feeder entries up to four positions at an angle of 90°.

A separate terminal box shall be provided for instrument current transformers, a heating anticondensating element, temperature sensors, etc.

18.3.4.4 Stator winding leads shall enter into a separate terminal box, other than those for lower voltages, through a sealing gasket.

A separate terminal box may be provided for neutral leads.

Terminals for earthing conductors of cables shall be provided inside terminal boxes. The reliable electrical connection shall be ensured in this case between the machine casing and the box body.

18.3.4.5 The motors rated at 1000 kW and over shall be fitted with differential protection devices. For this purpose, the motor casing shall be provided with a separate terminal box, located on the side opposite to the main terminal box, in which sufficient space for three current transformers and the leads of neutral winding ends shall be provided.

18.3.4.6 The temperature of bearings of motors rated at 1000 kW and over shall be monitored with local indicators (instruments). Each bearing shall be also provided with temperature sensors for remote monitoring.

18.3.4.7 In order to prevent the harmful effect of bearing currents, the bearing on the side opposite to the drive shall be electrically insulated from the casing. Provision shall be made for measuring insulation resistance for the insulated bearing without its assembly.

18.3.4.8 The plain bearing design shall provide for:
local indicators of the lubricating oil level;

a separate pump with a local pipeline, tank, cooler, filter and flow-rate indicator when forced circulating lubrication is used;

the possibility of installation of vibration monitoring instruments including necessary cable lines, as well as the instruments for measuring bearing wear;

interlocking of the motor starting when the lubricant is lacking.

18.4 POWER TRANSFORMERS

18.4.1 General.

18.4.1.1 Dry type transformers shall comply with IEC standard 60076-11.

The dry type transformers used shall be provided with earthed screens between the windings of high and low voltages.

Liquid cooled transformers shall comply with IEC standard 60076.

Cooling oil immersed transformers shall be provided at least with the following alarms and protections:

"Minimum liquid level" – alarm and automatic trip;

"Maximum liquid temperature" – alarm and automatic trip or load reduction;

"High gas pressure in enclosure" – automatic trip.

18.4.1.2 Transformers installed in spaces accessible to unqualified personnel shall have the degree of protection of enclosure not less than IP4X.

18.4.1.3 Where the low-voltage side of the transformers has an insulated neutral point, a spark-discharging fuse shall be provided between the neutral point of each transformer and the unit hull. The fuse shall be rated for not less than 80 % of the minimum test voltage for the services fed through the given transformer.

18.4.1.4 It is permitted to connect in parallel to the discharger the apparatus for monitoring insulation condition on low-voltage side of the installation or for detecting the location where this insulation is damaged. Such apparatus shall not interfere with reliable operation of the discharger.

18.4.1.5 Effective means (e.g. heating) shall be provided to prevent the accumulation and condensation of moisture inside the transformers when they are de-energised.

18.4.1.6 Use of aluminium as material for the transformer windings is permitted, provided the following conditions are met:

.1 provision is made for protection of the windings and their outlets from the corrosion in the conditions of the open sea;

.2 provision is made for protection from galvanic corrosion at the joints of the windings with current carrying parts made from other materials;

.3 joints indicated in [18.4.1.6.2](#) are accessible for inspection and protected from loosening.

18.5 CABLES

18.5.1 General.

Cables shall be constructed in accordance with the requirements of IEC 60092-353:2016 and IEC 60092-354:2020 or other international or national standards, provided they are of an equivalent or higher safety level than those stated above.

18.5.1.1 Three-core power cables with multiwire cores shall be used for a three-phase cable network. The cross-sectional area of the cable conductor for power circuits shall be not less than 10 mm².

18.6 SWITCHGEAR AND CONTROLGEAR ASSEMBLIES

18.6.1 General.

Distribution switchboard and controlgear shall be constructed according to IEC standard 62271-200:2011 and the following additional requirements.

18.6.2 Construction.

18.6.2.1 Mechanical construction.

Distribution switchboard shall be of metal-enclosed type in accordance with IEC 62271-200:2011 or of the insulation-enclosed type in accordance with IEC 62271-201:2014 or in accordance with the requirements of national standards.

18.6.2.1.1 Distribution switchboard shall be locked with a special key other than for the low-voltage switchboards and switchgear. Opening of doors or withdrawal of separate elements shall be feasible only after the disconnection of the panel concerned or the whole switchboard from the electrical network.

18.6.2.1.2 Passageways shall be provided along the switchboards for inspection of the switchboard and electrical apparatus and the width of the passageways shall be at least 800 mm between the bulkhead and the switchboard, and at least 1000 mm between the parallel sections of the switchboard. Where such passageways are intended for maintenance, their width shall be increased up to 1000 mm and 1200 mm, respectively.

The above width of these passageways is required irrespective of the means used for protection against contact, like doors, a net or insulated guard rails.

Doors, continuous bulkheads and net screens shall be at least 1800 mm high.

Perforated billheads or net screens shall ensure a degree of protection not below IP2X.

Two rows of insulated guard rails shall be fitted along the switchboard at the heights of 600 mm and 1200 mm.

18.6.2.1.3 Live parts of the electrical installation shall be separated from the protective guards by a distance not less than specified in [Table 18.6.2.1.3](#).

Table 18.6.2.1.3

Nominal voltage, kV	Minimum passageway height, mm	Minimum distance of live electrical parts from different protective guards, mm		
		solid doors and continuous bulkheads	net doors and screens	insulated guard rails
3 (3,3)	2500	100	180	600
6 (6,6)	2500	120	200	600
10(11)	2500	150	220	700
15	2500	160	240	800

18.6.2.2 Locking facilities.

Withdrawable circuit breakers used in the switchboards shall be provided with mechanical locking facilities in both service and disconnected positions. For maintenance purposes, key locking of withdrawable circuit breakers and other switches and fixed disconnectors shall be provided.

Withdrawable circuit breakers shall be located in the service position so that there is no relative motion between fixed and moving portions.

18.6.2.3 Shutters.

The fixed current-carrying contacts of withdrawable circuit breakers shall be automatically covered by insulating shutters when the circuit breaker is drawn out.

18.6.2.4 Earthing and interphase fault devices.

In order to ensure the safe maintenance of high voltage distribution switchboard, an adequate number of devices for forced busbar fault and earthing for busbars and outgoing feeders shall be provided.

Such device shall be designed for the maximum short-circuit current.

18.6.3 **Auxiliary supply systems.**

18.6.3.1 Source of supply.

Where a separate auxiliary electrical or other source of power is required for operation of circuit breakers and other switches, and also for protective devices, in addition to such a main source, a stand-by one, which an energy supply shall be sufficient for at least two operations of all the components, shall be provided.

However, the circuit breaker releases activated due to overload, short-circuit or undervoltage shall be independent of any electrical sources of power.

The requirement does not preclude using the shunt releases activated by an operating voltage, provided that the control of tripping circuits and their supply system integrity (continuity) will be ensured, i.e. if the integrity of the circuits is broken or their supply system is faulty (fails), an alarm will be activated.

18.6.3.2 Number of supply sources.

At least one independent stand-by source of power supply for split main switchboards (refer to [18.2.1.1](#)) for operation of circuit breakers and other switches, in addition to their own supply sources each fed from its own busbar system, shall be provided. Where necessary, an emergency source of electrical power intended for activation of the machinery installation from fully de-energized or dead ship condition may be used for this purpose.

18.6.4 **High-voltage tests.**

Every main and other switchboards shall be tested by a high voltage of standard frequency. The test procedure and voltage values shall meet the requirements of an appropriate national standard or IEC standard 62271-200:2011.

18.7 INSTALLATION

18.7.1 Electrical equipment.

18.7.1.1 Where high-voltage equipment is not contained in an enclosure but a special room forms the enclosure of the equipment, the access doors shall be so interlocked that they cannot be opened until the supply is isolated and the equipment earthed down.

At the entrance of the spaces or rooms where high-voltage equipment is installed, a caution notes shall be placed, which indicates danger of high-voltage.

18.7.1.2 In well-grounded cases, the electrical equipment may be installed outside special electrical rooms, provided the degree of protection is not below IP44 and access to current-carrying parts may be possible only in case the voltage is off or when special tools are used.

18.7.1.3 The connection circuit diagram and the arrangement plan of electrical equipment shall be available in the special electrical room.

18.7.2 Cables.

18.7.2.1 Cable run laying.

Cables shall not run through accommodation spaces. However, when required due to technological reasons, such laying is allowed in special enclosed transit systems (structures).

18.7.2.2 Segregation.

High-voltage cables shall be segregated from cables operating at the voltages below 1 kV. In particular, the high-voltage cables shall not run in the same cable bunch, nor in the same ducts or pipes, or in the same box.

Where high-voltage cables of different voltage ratings are installed on the same cable tray, the insulation distances between cables shall not be less than those specified for the higher voltage cables as per [18.2.3.1](#).

However, high-voltage cables shall not be installed on the same cable runs for the cables operating at the nominal voltage of 1 kV and below.

18.7.2.3 Installation of cables.

High-voltage cables shall be laid in metallic pipes or boxes, or they shall be protected with metallic enclosures.

The open installation of cables (on carrying pressed panels) is permitted if they are provided with continuous metallic armour which shall be reliable and repeatedly earthed.

18.7.2.4 Cable terminations.

Terminations in all conductors of high-voltage cables shall be effectively covered with suitable insulating material. In terminal boxes, if conductors are not insulated, phases shall be separated from earth and from each other by substantial barriers of suitable insulating materials. High-voltage cables having a conductive layer between phases to control the electric field within the insulation, shall have terminations, which provide electric stress control.

Terminations shall be of a type compatible with the insulation and jacket material of the cable and shall be provided with means to ground all metallic shielding components (metallic tapes, wires, etc.).

18.7.2.5 Marking.

High-voltage cables shall be readily identifiable by suitable marking.

18.7.2.6 Tests after installation.

Before putting into service of a new high-voltage cable network or after its modernisation (repair or additional cables installation), each cable and its accessories (terminations, earthing ends, etc.) shall be tested by a high voltage.

Tests shall be carried out after an installation resistance measurement.

When a d.c. voltage withstand test is carried out, the test voltage shall not be less than: $1,6 (2,5 U_0 + 2 kV)$ for cables of a rated voltage U_0 up to and including 3.6 kV; and $4,2 U_0$ for higher-rated voltages,

where U_0 is the rated power frequency voltage between each conductor and earth or a metallic screen, for which the cable is designed.

The test voltage shall be maintained for at least 15 min after completion of the test, the conductors shall be connected to earth for a sufficient time period in order to remove any trapped electric charge.

An insulation resistance measurement is then repeated.

When an AC voltage withstand test of high-voltage cable insulation is carried out (according to the manufacturer's recommendations), the test voltage shall not be less than the rated one and it shall not be less than the rated one and it shall be maintained for a minimum of 24 h.

Note. Test according to the requirements in IEC standard 60502-2:2005 are recognized by the Register as equivalent to given above.

19 SPARE PARTS

19.1 Each MODU shall be provided with spare parts in the amount sufficient for repairing when essential services fail at any situation, an accident at sea inclusive, in order to ensure movement, control and safety of a MODU and people on board.

19.2 When determining the spare parts standards, one shall be guided by the recommendations of manufacturers of specific equipment.

APPENDIX

Table 1

Alarm-matrix for AC machines: synchronous, permanent-excited and asynchronous motors

Monitored value	Limiting value Max/Min	Applicable for:	Local diagnostic tool	Action alarm, display in the main machinery control room	Action reduce	Action stop	Indication on main control station (bridge)
Motor							
External lubrication	Failure		Inspection glass	X	X	X	X
Bearing temperature	Max		Thermometer	X			X
Stator winding temperature	Max			X	X		X
Slip rings	Failure (Voltaic arc)	Synchronous motor	Inspection glass and inspection flaps	X			X
External cooling, water/air	Failure			X			X
Cooling air temperature, engine inlet at closed loop cooling system	Max		Thermometer	X			X
Coolant	Leakage			X			X
Speed	Max.			X		X	X
Voltage regulator	Breakdown	Synchronous motor		X		X	X
Earth fault monitoring of stator with transformer feeding	Min			X			X
Earth fault monitoring of exciting system with transformer feeding	Min	Synchronous motor		X			X
Transformers							
Transformer winding temperature	Max			X	X		X
Coolant	Leakage			X			X
External cooling	Failure			X			X
Converters							
Mains	Failure			X		Start	X
External cooling	Failure			X	X		X
Power section temperature	Max			X		X	X
				Max 1		Max 2	
Coolant quality	Min			X			X
Coolant	Leakage			X			X
Warning							
Breakdown							
Speed-/rotor position sensor detection	Failure	Synchronous motor		X		X	X
Emergency stop (converter de-energized)				X		X	X
Semiconductor fuse	Failure			X		X	X

Monitored value	Limiting value Max/Min	Applicable for:	Local diagnostic tool	Action alarm, display in the main machinery control room	Action reduce	Action stop	Indication on main control station (bridge)
Chopper temperature	Max			X	Reduce breaking torque		X
DC link, voltage	Max			X		X	X
DC link, current	Max			X		X	X
Output current	Max			X		X	X
Propulsion system supply, MODU electrical power plant							
Harmonic filter	Breakdown			X			X

Table 2

Alarm-matrix for direct current motors

Monitored value	Limiting value Max/Min	Local diagnostic tool	Action alarm, display in the main machinery control room	Action reduce	Action stop	Indication on main control station (bridge)
Motor						
External lubrication	Failure	Inspection glass	X	X	X	X
Bearing temperature	Max	Thermometer	X			X
Main poles temperature	Max		X	X		X
Interpoles or compensation windings temperature	Max		X	X		X
External cooling, water or air	Failure		X			X
Cooling air temperature, engine inlet at closed loop cooling system	Max	Thermometer	X			X
Coolant	Leakage		X			X
Speed	Max		X		X	X
Commutator/ brushes	Failure (voltaic arc)	Inspection glass and inspection flaps	X			X
Armature current	Max		X		X	X
Earth fault monitoring armature circuit with transformer feeding	Min (ironwork fault)		X			X
Transformers						
Transformer winding temperature	Max		X	X		X
Coolant	Leakage		X			X
External cooling	Failure		X			X
Converters						
Mains	Failure		X		Restart	X

Monitored value	Limiting value Max/Min	Local diagnostic tool	Action alarm, display in the main machinery control room	Action reduce	Action stop	Indicatio n on main control station (bridge)
External cooling	Failure		X	X		X
Power section temperature	Max		X		X	X
			Max 1		Max 2	
Coolant quality (only at direct cooling)	Min		X			X
Coolant	Leakage		X			X
Warning						X
Breakdown			X		X	X
Speed sensor	Failure		X			X
Emergency stop (Converter de-energized)			X		X	X
Semiconductor fuse	Failure		X		X	X
Propulsion system supply, MODU electrical power plant						
Harmonic filter	Breakdown		X			X

Russian Maritime Register of Shipping

Rules for the Classification and Construction of Mobile Offshore Drilling Units

**Part X
Electrical Equipment**

FAI "Russian Maritime Register of Shipping"
7, Litera A, Millionnaya Ulitsa,
St. Petersburg, 191186,
www.rs-class.org/en/