

RUSSIAN MARITIME REGISTER OF SHIPPING

RECOMMENDATIONS
FOR DESIGN, CONSTRUCTION
AND OPERATION OF SUBSEA
PIPELINES

ND No. 2-090601-007-E



Saint-Petersburg
Edition 2019

Recommendations for Design, Construction and Operation of Subsea Pipelines of Russian Maritime Register of Shipping have been approved in accordance with the established approval procedure and come into force since its publication.

These Recommendations have been prepared taking into account the experience in technical supervision during design, construction and operation of subsea pipelines.

The Recommendations contain the required information for designers including reference data that are not included and is in addition to the provisions of the Rules for the Classification and Construction of Subsea Pipelines and the Guidelines on Technical Supervision during Construction and Operation of Subsea Pipelines and cover the following aspects related to steel subsea pipelines:

- specifics of the design procedure for subsea pipelines;
- determination of the most appropriate size of a pipeline;
- engineering surveys for the design of subsea pipelines;
- determination of design loads;
- strength of subsea pipelines;
- ballasting of subsea pipelines;
- laying of subsea pipelines;
- corrosion protection with the application of coatings;
- electrochemical corrosion protection;
- crossings of subsea pipelines (between each other and with the shoreline);
- risk analysis and reliability;
- survey and repair of subsea pipelines.

The Recommendations provide examples of the use of calculation procedures recommended for the use in designing subsea pipelines, as well as references at the end of each section specifying the regulatory and recommended research technical literature.

The Recommendations are intended for the RS surveyors.

In case of discrepancies between the Russian and English versions, the Russian version shall prevail.

1 GENERAL

Currently, the pipeline transportation of gas, oil and petroleum products is the primary means of delivering these products from places of production, processing or recovery to places of demand.

Subsea pipeline is a structural part of the pipeline transportation system located below the water level, including the pipeline itself, an external insulating corrosion-protection coating, as well as a protective concrete coating that protects the insulation coating against mechanical damage, ensures the pipeline stability on the seabed soil and prevents the pipeline floating-up.

Subsea pipelines are laid below the water level in sea areas and at the crossing of water barriers: rivers, water-storage reservoirs, lakes etc. In the former case, especially taking into account the development of the infrastructure of offshore hydrocarbon fields, subsea pipelines may be infield (i.e. connecting, for example, fixed offshore platforms of various purposes at the same field) and interfield (to transport product from the facilities of one field to the other), as well as export pipelines transporting well fluids or prepared products from the offshore facility to the onshore facilities or main pipelines for prepared product transportation.

In addition to the operating pressure of transported product, special operating conditions of subsea pipelines are caused by exposure to external hydrostatic pressure of water, effects of wave, current, ice formations, soil foundation responses as well as natural and technogenic accidental loads. Pipes for subsea pipelines are generally manufactured of low alloy steel of various strength categories depending on the operational reliability level and design loads. The wall thickness of the pipes is determined by calculation depending on the internal pressure, product type being transported, external design loads, laying forces, etc. Sea water and seabed exposure as corrosive medium shall be considered.

1.1 SCOPE OF APPLICATION

1.1.1 The present Recommendations for Design, Construction and Operation of Subsea Pipelines¹ are applied to items of technical supervision of Russian Maritime Register of Shipping² during review of design and detailed design documentation, manufacture of materials and products for subsea pipelines, as well as during technical supervision of subsea pipeline systems with the RS class in operation.

1.1.2 Calculation methods provided herein are recommendations only. The requirements of the Rules for the Classification and Construction of Subsea Pipelines³ and the Guidelines on Technical Supervision during Construction and Operation of Subsea Pipelines⁴ are taken into account in the Recommendations.

1.1.3 The Recommendations provide, as an example, the elements of design calculation of an offshore gas pipeline in the northern part of the Caspian Sea (refer to 1.2). In the process of the design, the loads from the current and waves were calculated, the wall thickness was determined, and the pipeline strength was checked considering the sea-bottom profile. The pipeline ballasting is also calculated and the process of laying the pipeline is reviewed. The parameters of galvanic anode protection are selected.

1.2 INITIAL DATA FOR SAMPLE CALCULATIONS

The Recommendations contain calculation procedures based on the engineering methods for determining the parameters of a subsea pipeline and its route in the Russian sector of the northern part of the Caspian sea selected as an example (refer to Fig. 1.2).

¹ Hereinafter referred to as "the Recommendations".

² Hereinafter referred to as "the Register, RS".

³ Hereinafter referred to as "the SP Rules".

⁴ Hereinafter referred to as "the SP Guidelines".

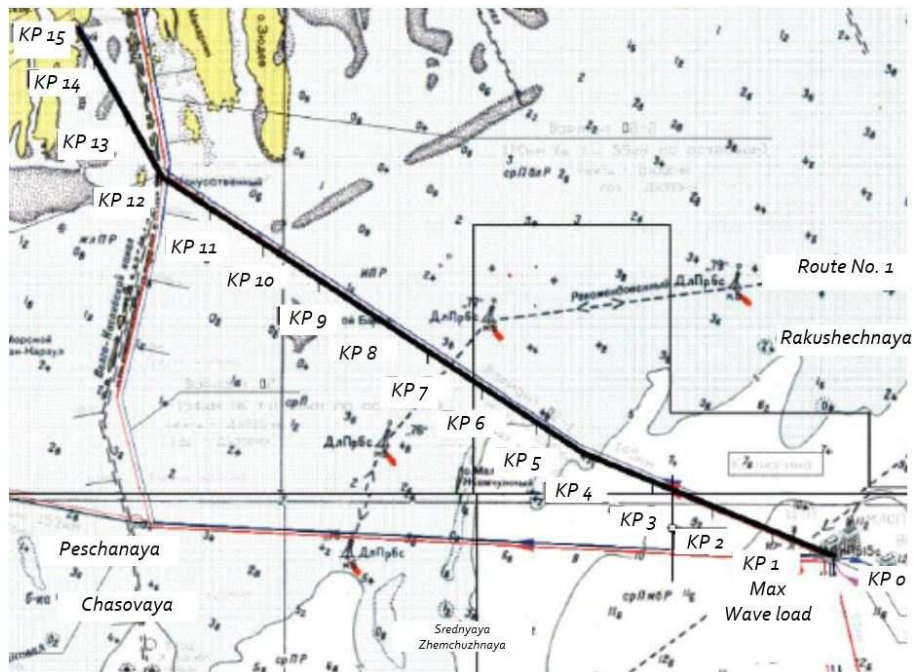

Fig. 1.2 Plan of designed subsea pipeline route

The initial characteristics of this subsea pipeline for calculation procedures are as follows:

- length of the pipeline — 145 km;
- outside diameter of the steel pipeline — 350 mm;
- external corrosion-protection coating — 3-layer polyethylene, density — 950 kg/m^3 , minimum thickness — 2,2 mm;
- ballasting concrete coating: density — 2700 kg/m^3 and thickness — 80 mm;
- transported medium: gas;
- pipeline wall thickness: 12 mm;
- laying scheme: non-buried pipeline;
- operating pressure: 8 MPa;
- near-bottom current velocity — 0,68 m/s;
- wave characteristics of 1 % probability with average depth of 9,6 m of water area:
 - wave height — 4,9 m;
 - wave length — 85 m;
 - wave period — 8,4 s;
- maximum temperature of transported medium — $50 \text{ }^\circ\text{C}$;
- average ambient temperature (sea water) — $11 \text{ }^\circ\text{C}$.

2 SPECIFICS OF SUBSEA PIPELINES DESIGN

2.1 LEGAL FRAMEWORK OF DESIGN, CONSTRUCTION AND OPERATION OF SUBSEA PIPELINES

2.1.1 Relevant international and national regulatory instruments considering legal status of different maritime zones and internal sea waters shall be observed during design, construction and operation of pipeline transportation routes in maritime zones.

The maritime zones that are potentially used for laying and operation of pipeline transportation routes include Territorial Sea, Exclusive Economic Zone (EEZ), Contiguous Zone High Seas, Continental Shelf and Internal Waters (refer to Fig. 2.1-1).

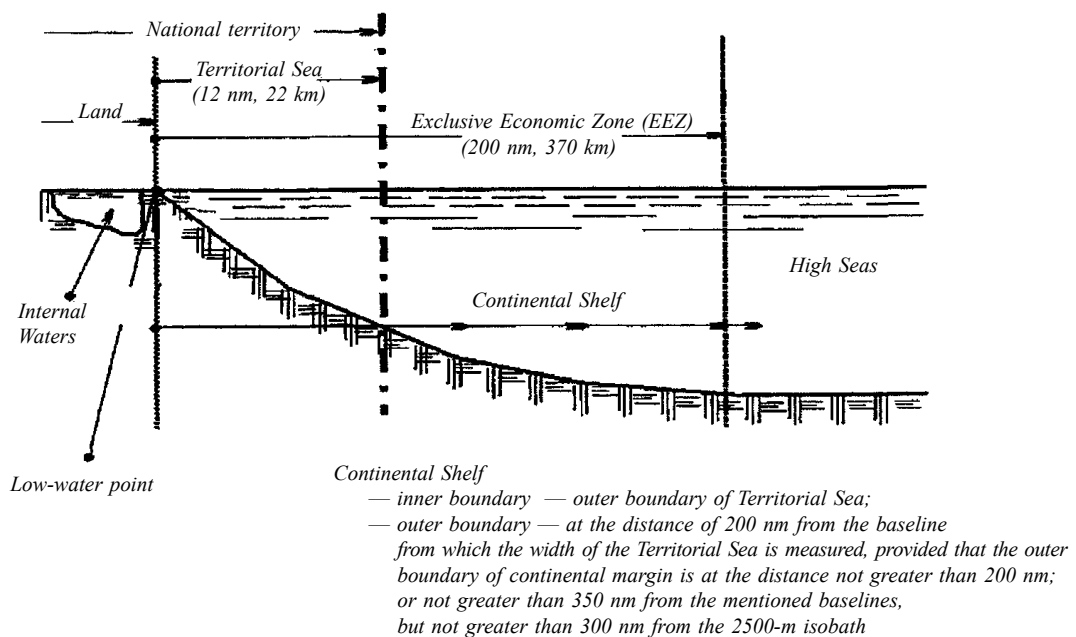

Fig. 2.1-1 Legal status of maritime zones [4]

Legal status of the specified maritime zones is determined by their relation to the state territory.

Territorial Sea is the contiguous maritime belt which extends up to 12 miles beyond the territorial sea limit measured according to the standards of international law and the RF legislation (refer to Article 15 of the Water Code of the Russian Federation).

Exclusive Economic Zone (EEZ) is the area beyond and adjacent to the Territorial Sea of the Russian Federation, with special legal status prescribed and regulated by the RF legislation and the standards of the international law. Internal border of EEZ is the external border of the Territorial Sea. The external border of EEZ is at distance of 200 miles from initial lines from which width of the Territorial Sea is measured if other is not provided by international treaties of the Russian Federation (refer to Article 1, Federal Law No. 191-FZ of 17 December 1998 "On Exclusive Economic Zone of the Russian Federation").

Continental Shelf of the Russian Federation includes seabed and subsoil of the underwater areas outside the RF territory throughout natural continuation of its overland territory to external border of the underwater suburb of the continent. The underwater suburb of the continent is continuation of the continental array of the Russian Federation including surface and subsoil of the continental shelf,

slope and rise (refer to Article, Federal Law No. 187-FZ of 30 November 1995 "On the Continental Shelf of the Russian Federation").

Internal Waters are waters outside the RF territory excluding the territorial sea of the Russian Federation (refer to Article 18 of the Water Code of the Russian Federation).

Unlike the open sea, the territorial sea and internal waters form a part of the state territory, and there the main applicable law is the national legislation of the relevant coastal state, which is implemented in compliance with international law (first of all, observing the free passage of a foreign ship through the territorial sea).

2.1.2 High Seas include a part of seabed located outside a state territory. The 1982 UN Convention on the Law of the Sea (hereinafter referred to as "the Convention") ratified by the Russian Federation in 1997 is the main international statute that contains the legal framework to regulate shipping and to provide sea shipping services, including use of subsea pipeline systems.

The Convention contains a number of articles related to the issues of pipeline laying and operation. In particular, Article 79 of the Convention "Submarine Cables and Pipelines on the Continental Shelf" stipulates the following:

states are entitled to lay submarine cables and pipelines on the continental shelf;

coastal state may not impede the laying or maintenance of such cables or pipelines;

delineation of the course for the laying of such pipelines on the continental shelf is subject to the consent of the coastal state;

coastal state is entitled to establish conditions for cables or pipelines entering its territory or territorial sea, or its jurisdiction over cables and pipelines constructed or used in connection with the exploration of its continental shelf or exploitation of its resources or the operations of artificial islands, installations and structures under its jurisdiction;

when laying submarine cables or pipelines, states shall have due regard to cables or pipelines already in position; in particular, possibilities of repairing existing cables or pipelines shall not be prejudiced.

The intensive development of offshore oil and gas production in the Caspian Sea, which is a closed intracontinental water area without natural connection with the World Ocean, was one of the reasons for the signing the Convention on the Legal Status of the Caspian Sea on 12 August 2018 at the Fifth Caspian Summit held in Astana (the Republic of Kazakhstan). In addition to the above-mentioned maritime zones, the Convention provides the concept of "sector" that means a part of the seabed and subsoil delimited between the Parties of the Convention (the Caspian littoral states: Azerbaijan, Iran, Kazakhstan, Russian Federation and Turkmenistan) for the purposes of the subsoil exploitation, development of resources of the seabed and subsoil and other legitimate economic activities. The provisions of the Convention provide for the possibility of laying subsea pipelines and cables along the bottom of the Caspian Sea (refer to Article 14). The following shall be taken into account:

subsea pipeline projects shall comply with environmental requirements of the Framework Convention for the Protection of the Marine Environment of the Caspian Sea (signed by all Caspian littoral states on 4 November 2003, ratified by the Russian Federation on 12 August 2006) and its relevant protocols;

design of subsea pipeline or cable shall be determined by agreement with the Party the seabed sector of which shall be crossed by the cable or pipeline;

geographical coordinates of areas along routes of submarine cables and pipelines where anchoring, fishing with near-bottom gear, submarine and dredging operations, and navigation with dredging anchor are not allowed, shall be communicated by the coastal state whose sector they cross to all the Parties.

Subsea pipelines of various purposes have an important role in the development and operation of a subsea hydrocarbon field: from flow lines to export pipelines, without which the operation of an offshore field and subsea sections of main pipelines is not possible (refer to Fig. 2.1-2).

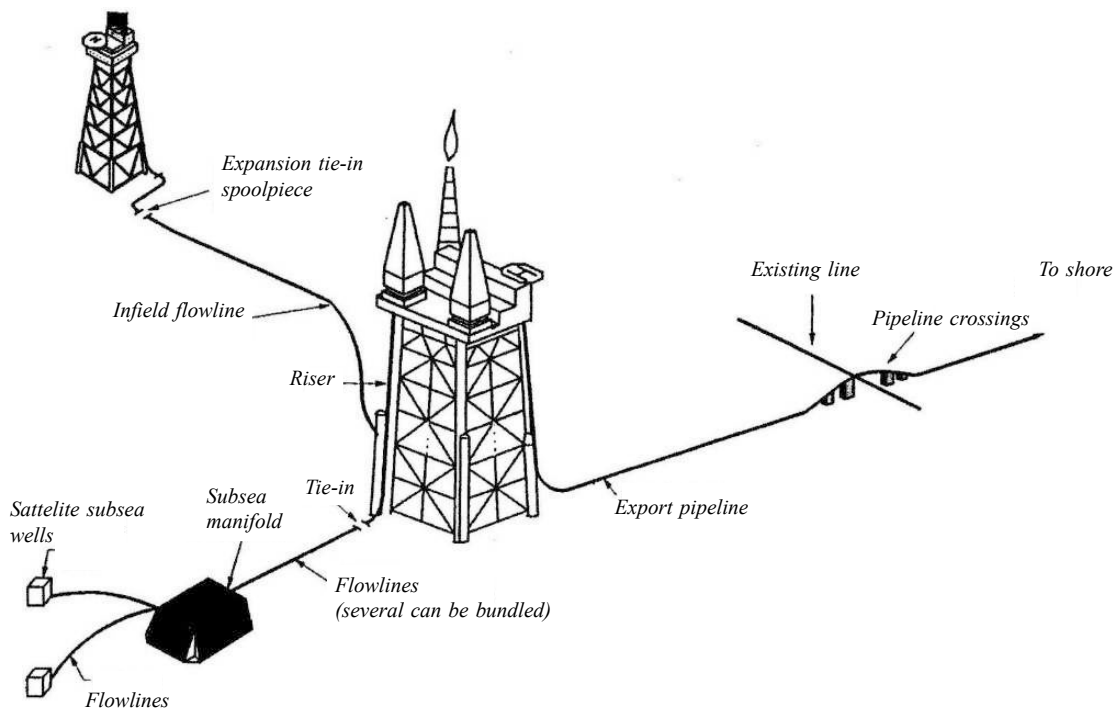

Fig. 2.1-2 Pipelines as part of subsea hydrocarbon field facilities [12]

2.2 REQUIREMENTS OF NATIONAL REGULATORY AND LEGAL INSTRUMENTS

2.2.1 Design, laying and operation of subsea pipelines on the continental shelf and related facilities in the Russian Federation is governed by the relevant state regulatory and legal instruments. In particular, in accordance with Article 6 of the Federal Law of 30 November 1995 No. 187-FZ "On the Continental Shelf of the Russian Federation", regulation of the conditions for laying and determining the route of subsea pipelines and cables on the continental shelf of the Russian Federation is the responsibility of the federal state authorities.

Subsea pipelines and cables on the continental shelf of the Russian Federation, which are used for the production of mineral resources, are subject to routing and laying upon agreement with the federal executive body. However, if the owner's license for the use of subsoil grants the right to lay subsea pipelines and cables in accordance with the design documentation provided for by the Russian legislation (refer to 2.3), permission to lay such subsea pipelines and cables is not required.

For subsea pipelines and cables not specified in the license for the use of subsoil and not related to the development of mineral resources of the continental shelf of the Russian Federation, but which are routed on the territory of the Russian Federation, the issue of permissions for their laying is carried out by the Federal Service for Supervision of Natural Resources (Rosprirodnadzor), which is established by Government Resolution No. 417 of 9 June 2010 [1].

Requirements for the operation of subsea pipelines related to the production and transportation of hydrocarbons on the shelf include the following (refer to Article 22, No. 187-FZ "On the Continental Shelf of the Russian Federation"):

- available Oil Spill Prevention and Response Plan approved according to the established procedure;
- installation of marine environmental monitoring systems, including the detection of oil and petroleum product spills, and spill alerts;
- providing funding for activities under Oil Spill Prevention and Response Plan, including full compensation for damage to the environment;
- available of rescue units of their own or engaging on a permanent contractual basis for the prevention and elimination of spills.

2.2.2 The legal basis for laying subsea pipelines and cables in the internal waters, the territorial sea and the adjacent zone of the Russian Federation is Federal Law No. 155-FZ of 31 July 1998 "On Internal Waters, territorial sea and contiguous zone of the Russian Federation" [7], Article 16 of which specifies the procedure for laying subsea pipelines and cables, as well as the requirements for the operation of subsea pipelines in terms of prevention and response to accidents, spills of oil and oil products, similar to those specified in 2.2.1.

A similar procedure is established for obtaining permission for laying subsea pipelines and cables in internal waters and territorial sea — when securing the right to lay subsea pipelines and cables in a license, a permission issued by a state executive authority is not required. Otherwise, the permission is issued by Rosprirodnadzor on the basis of the Resolution of the Government of the Russian Federation No. 68 of 26 January 2000 [2]. In accordance with this instrument, subsea cables and pipelines of any purpose may be laid in the internal waters and in the territorial sea of the Russian Federation, provided that these actions do not interfere or impede ensuring the protection of the state border, conducting regional geological exploration, exploration and development of mineral resources or the harvesting of living resources, operation and repair of previously laid subsea pipelines and cables. To obtain relevant permission, the following information shall be provided:

- purpose and intended use of the subsea pipeline or cable;
- pipeline routing with the coordinates of the starting, ending and turning points of the route;
- scheduled dates of works and data on ships intended for use during laying;
- design documentation for laying the subsea pipeline or cable;
- measures to prevent or reduce possible damage to the marine environment, to prevent and eliminate emergencies.

The application for the issue of a permission is reviewed by Rosprirodnadzor and agreed upon with other relevant federal executive bodies, the list of which is specified in [2]. Based on the conclusion on the possibility of passing the subsea pipeline, a decision is made to issue a permission to carry out the specified works, or to refuse to issue such a permission. In case of obtaining a permission, the applicant shall ensure that the requirements of applicable legal documents during laying and operation of the subsea pipeline are complied with.

2.2.3 To implement the procedure for reviewing and issuing permissions for laying subsea pipelines and cables in inland waters, the territorial sea of the Russian Federation and on the continental shelf of the Russian Federation Rosprirodnadzor has developed the Regulations [3], the provisions of which specified terms, list and sequence of actions when providing services on issue of permissions for laying subsea pipelines to individuals and/or legal entities planning to carry out laying subsea pipelines along a specific route in the internal waters, the territorial sea of the Russian Federation and on the continental shelf. The provisions of the Regulations determine the list and requirements for documentation submitted for review, a set of actions and terms for the implementation of administrative procedures, subject to compliance with the form of the submitted application with the requirements of the Regulations. This instrument also specifies the procedure for approval of submitted applications with federal executive bodies and the procedure for making a decision on issue or refusing to issue a permission for laying the subsea pipeline.

2.3 TECHNICAL DOCUMENTATION

2.3.1 General.

2.3.1.1 Generally, the basis for the development of design documentation on offshore pipeline systems is the following:

.1 customers' investment programs related to offshore hydrocarbon field development projects or export pipeline transport in sea water area;

.2 customer's license commitments for prospecting, exploration and production of hydrocarbons (using subsea pipelines as part of field facilities in the internal maritime waters, the territorial sea and continental shelf of the Russian Federation). The subsoil license grants its owner the right to lay subsea pipelines in accordance with the design documentation as provided for in the RF legislation on subsoil [3] and laws on urban planning [4].

2.3.1.2 Generally, the initial data for the development of design documentation on offshore pipeline systems are the following:

.1 performance specification approved by the customer;

.2 technical report on the results of integrated engineering survey along pipeline routes and temporary local specifications for hydrometeorological, hydrological, ice conditions and initial design data;

.3 special technical conditions for design of linear facilities of subsea pipeline systems, which are developed and approved according to the established procedure prior to developing the design documentation if the reliability and safety requirements established by regulatory technical documents are not sufficient for the development of design documentation, or such requirements have not been established;

.4 characteristics of the main indicators of deposit development of offshore oil-and-gas field;

.5 physical and chemical properties of oil and stable gas condensate, gas fractional analysis and properties;

.6 demand for gas lift and the water injection dynamics;

.7 process and design solutions for the subsea pipeline system.

2.3.1.3 Construction of subsea pipelines and manufacture of materials and products for them shall be carried out in compliance with the technical documentation approved (agreed) by the Register.

Review (expertise) of the design technical documentation aims at verification of the compliance of the items of technical supervision with the requirements of the RS rules and the possibility of assigning the RS class to the subsea pipeline.

Prior to commencement of the subsea pipeline construction, detailed design (construction and production) technical documentation shall be submitted to the Register for review to ensure that the requirements of the design approved by the Register and the RS rules for this subsea pipeline are met.

2.3.1.4 In accordance with the provisions of 1.1.7 and 1.1.9, Part I "Subsea Pipelines" of the SP Rules, the Register may allow to use materials, structures, arrangements and products, other than those required by the SP Rules in the design of the subsea pipeline provided that they are as effective as those specified in the SP Rules. In the above cases, data shall be submitted to the Register to verify the compliance of those materials, structures, arrangements and products in question with the requirements ensuring the safety of media transportation through subsea pipelines.

The Register may approve subsea pipelines constructed in compliance with other regulations, rules or standards alternatively or in addition to the SP Rules.

2.3.1.5 Types of technical documentation to be reviewed by the Register at the subsea pipeline design and construction stages are specified in 1.5.3 of the SP Guidelines.

2.3.2 Design documentation.

2.3.2.1 As the current practice of design development in the Russian Federation shows, subsea pipelines are designed, in general, for the entire system of field facilities on the sea shelf with the "Linear facilities" design section being singled out for subsea pipeline facilities [5].

For the subsea pipelines in the exclusive economic zone, on the continental shelf, in the internal sea waters and/or in the territorial sea of the Russian Federation, the designs shall be subject to the state expert

appraisal of design documentation in accordance with the Town-planning Code of the Russian Federation [4]. In addition, subsea pipeline systems of various purposes intended for hydrocarbon transportation shall comply with the requirements of the RF legislation on industrial safety of hazardous production facilities [6].

2.3.2.2 The design documentation of the subsea pipeline to be reviewed by the Register shall include the following:

- technical background;
- design of the pipeline right of way (ROW) (in case of shore route section);
- process and structural solutions;
- construction management plan;
- route plans and longitudinal profile of pipeline;
- technical requirements for materials and products;
- Industrial Safety Declaration of Hazardous Production Facilities.

2.3.2.3 Technical background shall contain information on the following:

climatic, geographical and engineering and geological characteristics of the water area/location where the construction of the subsea pipeline is planned;

descriptions of pipeline route alternatives with substantiation of the selected alternative;

information on the pipeline with indication of pipeline name, intended purpose and location of its initial and end points;

technical and economic features of the designed linear facility (category, length, capacity, basic parameters of the longitudinal profile and ROW, etc.);

descriptions of the conceptual design solutions that ensure the reliability of the pipeline, the sequence and stages of its construction, the scheduled commissioning dates.

2.3.2.4 The design of the subsea pipeline system shall include process and structural solutions:

.1 technical backgrounds on the following:

process solutions of the designed subsea pipeline including calculations of process parameters of the pipeline;

structural solutions of the designed subsea pipeline including calculations of structural parameters of the pipeline;

selection of type and parameters of the electrochemical protection against corrosion of the pipeline or its sections;

selection of types and parameters of corrosion-protection/thermal insulation/anti-friction coatings of the pipeline including insulation of butt welded joint;

process solutions for automation, leak-detection and/or corrosion control systems (if any);

.2 layouts of intercept valves;

.3 bracelet anode attachment points;

.4 diagram of pipe joint insulation;

.5 connection points to standpipes of fixed offshore platforms (spool pieces) or subsea manifolds;

.6 shore approaches and crossings with previously constructed pipelines, sea channels (fairways) and subsea cables;

.7 requirements for ensuring safe operation;

.8 specifications of equipment, products and materials.

2.3.2.5 The design of the subsea pipeline system shall include a construction management plan:

technical background on construction management plan including methods of laying and burial in the seabed (if any);

technical background on route crossing and shore approach design (if any);

logistics scheme of delivering pipes and materials;

layout of land plot;

route plans and route crossing plans (if any);

longitudinal profiles of routes and longitudinal profiles of route crossings (if any).

2.3.2.6 The subsea pipeline design shall contain the technical requirements for equipment, products and materials including:

- steel pipes, bends and fittings;
- flexible pipes (if any)
- corrosion-protection/thermal insulation coating of steel pipes;
- insulation of pipe joints;
- internal anti-friction coating of pipes (if any);
- pipeline ballasting (weight coatings and/or weights, if any)
- galvanic anodes or cathodic protection station (if any);
- automation, leak-detection and/or corrosion control systems (if any);
- flanged joints of the types used;
- magnetic markers.

2.3.2.7 Subsea pipelines may not be operated in the internal sea waters and in the territorial sea in accordance with [7] unless an Oil Spill Response Plan (emergency response plan) is available, which is approved in accordance with the established procedure and in according to which measures are planned and taken for spill prevention and response. The Oil Spill Prevention and Response Plan may be an integral part of the design documentation of the subsea pipeline. Oil Spill Prevention and Response Plan that is available and implemented by the owner/operator is a mandatory requirement when accepting the pipeline in operation to the RS class.

2.3.2.8 Documentation on risk analysis shall be prepared in compliance with Section 10, Part I "Subsea Pipelines" of the SP Rules. It is allowed to perform risk analysis for the subsea pipeline through the stages of the offshore field development project design including within the framework of the development of the Industrial Safety Declaration of Hazardous Production Facilities.

2.3.2.9 Upon review of the subsea pipeline design the Register shall issue a conclusion letter, with indication of the following:

- a list of regulatory documents, for compliance with which the design documentation was reviewed at the customer's request in addition to the SP Rules;

- the RS comments upon the results of the design documentation review with indication of elimination monitoring method;

- possibility of assigning the RS class with its indication;

- a list of the reviewed technical documentation with notes on the review results;

- information on the approval by RS of materials, structures, arrangements and products other than those required by the SP Rules, provided they are as effective as those specified by the SP Rules.

2.3.3 Detailed design documentation.

2.3.3.1 In order to implement technical and process solutions specified in the design documentation on the offshore pipeline system facilities in the process of pipeline construction, detailed design documentation containing text documents, design drawings, specifications of equipment and products, process flow diagrams and procedures used for the construction and testing of the subsea pipeline shall be developed.

2.3.3.2 Detailed construction and process documentation is developed based on the offshore pipeline system design approved by the Register and the relevant competent supervisory bodies. In this case, the RS comments, which were indicated in the RS conclusion letter as subject to elimination at the detailed design stage, shall be taken into account in the detailed design documentation.

2.3.3.3 Detailed construction and process documentation shall be subject to the RS approval prior the construction of a subsea pipeline and the commencement of technical supervision during its construction.

2.3.3.4 Documentation on steel pipes and pipeline.

2.3.3.4.1 The technical documentation to be submitted shall contain the data on materials, geometric dimensions, techniques and procedures used for steel pipe manufacture including welding (for welded pipes). The following shall be submitted for the RS review (the scope of the detailed design documentation for manufacture of materials and products, as well as construction of pipelines is provided in the relevant sections of the SP Guidelines):

.1 specifications and procedures for manufacture of steel pipes with indication of types and scope of tests and non-destructive testing (NDT) including base metal and welded joints;

.2 welding procedures including repair welding in manufacture of welded pipes and welding of butt girth welds with indication of the methods and scope of non-destructive testing;

.3 drawings of plans and longitudinal profiles of pipelines;

.4 drawings of bends, T-joints and reducers;

.5 drawings of spool pieces;

.6 drawings of pre-developed trenches and pits;

.7 general layout plan.

.8 installation diagram of magnetic markers.

2.3.3.4.2 The following procedures and calculations shall be submitted together with the drawings:

.1 procedure for laying the linear section of the subsea pipeline;

.2 procedure for laying in the vicinity of the landfall or crossing with other pipelines/subsea cables;

.3 procedure for pipeline string joining (tie-in);

.4 necessary information for determination of external loads (forces and moments) due to wind, currents, waves, ice formations and other parameters including accidental loads (caused by trawl nets, anchors, etc.) to be taken into account in the pipeline strength analysis;

.5 calculation of the pipe wall nominal thickness for appropriate load combinations;

.6 pipeline strength analysis during laying with assigned safe parameters for waves, currents and wind;

.7 calculations to confirm the seismic resistance of subsea pipeline;

.8 calculations of subsea pipeline burial depth for the ice exaration areas;

.9 calculations of strength of spool pieces and flanged joints;

.10 calculations of permissible free-spanning pipelines at the stage of construction, hydraulic testing and operation.

Documentation on pipeline ballasting:

.1 calculation of subsea pipeline buoyancy (buoyant force), check of on-bottom and/or floating-up stability;

.2 design drawings of the weight coating and/or ballast weight construction;

.3 ballasting calculation for the subsea pipeline when using concrete coated pipes.

Documentation on valves and their drives:

.1 arrangement plan for shut-off and safety valves;

.2 documentation and test reports on valves that confirm their suitability for the media to be transported and anticipated operational conditions;

.3 documentation on fastenings for flanged joints and gaskets;

.4 diagram of the pipeline valves remote control.

2.3.3.7 Documentation on flanged joints.

Documentation on flanges submitted for the RS review shall contain the following:

.1 number of flanges of specific type of each size and pressure class within the design;

.2 applied design standard and verification assessment of strength for taking up the design forces;

.3 material grade, type of billets;

.4 product geometry (e.g. nominal or internal diameter, minimum neck wall thickness, thickness and diameter of flange body, projections and grooves on contact surface, treatment of contact surfaces, deviations from the circular shape of section including required tolerances), dimensions of connected pipe;

.5 heat treatment conditions after manufacture;

.6 requirements for scope and test procedures of type (pilot) specimen and specified during manufacture;

.7 requirements for non-destructive testing and hydraulic tests;

.8 surface conditions at supply, coatings or painting.

2.3.3.8 Documentation of bends and fittings.

Documentation on bends submitted for the RS review shall contain the following:

.1 number of bends of specific type of each size within the design and applied manufacture standard;

.2 material grade, type of billets;

.3 specification and certificates for billet material indicating data on chemical composition, heat treatment, mechanical properties, dimensional inspection and non-destructive testing;

.4 bend geometry (e.g. nominal or internal diameter, minimum wall thickness, bending radius, bending angle, lengths of straight sections on bend edges, treatment of ends, deviations from the round section shape including required tolerances);

.5 heat treatment conditions after manufacture, if applicable;

.6 requirements for the scope and methods of testing for bend metal specimens;

.7 requirements for non-destructive testing and hydraulic testing;

.8 surface conditions at supply, coatings or painting.

The following information on fittings shall be additionally submitted:

.1 methods and parameters of forming (forging, stamping, casting), welding, machining;

.2 welding procedure and chemical composition of weld metal including repair by welding.

Documentation on laying the pipeline:

.1 laying methods and process flow diagrams with indication of basic parameters;

.2 procedures for preparing trenches and pits, forming of backfilling of trenches and pits;

.3 design of crossings with previously laid subsea pipelines and cables;

.4 calculations of pipeline strength during seabed

burial and design of crossings with previously laid subsea pipelines and cables.

2.3.3.10 Documentation on automated control, alarm, corrosion monitoring and leak-detection systems:

.1 diagrams of automated control systems and specifications for their design and manufacture including test programs;

.2 list of parameters to be monitored with the relevant types of sensors and devices, and their characteristics specified;

.3 certificates for instrumentation and other components of the systems.

2.3.3.11 Documentation on corrosion protection and insulation including thermal insulation:

.1 specifications for the application of corrosion-protection coatings and insulation;

.2 scheme of corrosion-protection coating and insulation;

.3 insulation schemes of welded pipe joints;

.4 instructions on repair of insulated surface of the pipeline.

Documentation on electrochemical protection of pipeline:

.1 cathodic protection scheme (anodes arrangement) or galvanic anode protection;

.2 specifications for cathodic protection station (if any);

.3 determination of weight of anodes or galvanic anodes;

.4 documentation on electrical insulating joints and/or flanges.

2.3.3.13 Detailed design documentation review by the Register is required for carrying out technical supervision during construction of a subsea pipeline, manufacture of materials and products for it and for assignment of the RS class based on the survey results of a subsea pipeline under construction.

2.3.4 As-built documentation.

2.3.4.1 When the Register provides services on classification of subsea pipelines built without the RS technical supervision based on 1.4.4.3, Part I "Subsea Pipelines" of the SP Rules, as-built documentation shall be reviewed and approved by the Register in addition to design and detailed design documentation for construction of a subsea pipeline.

2.3.4.2 As-built documentation is prepared by the contractor carrying out construction of the subsea pipeline based on Order of the Federal Environmental, Industrial and Nuclear Supervision Service of Russia (Rostekhnadzor) No. 1128 of December 26, 2006 [8].

2.4 GENERAL PRINCIPLES OF SUBSEA PIPELINE DESIGN

In the design process, the most appropriate location for the pipeline structure under water shall be selected considering the following:

- safety of operation, ecology, cost of construction, production effectiveness, etc.;
- selection of pipe material, protective coating and electrochemical protection;
- buckling stability and lateral stability of the structure considering the effect of underwater currents, wave particle flow and buoyancy forces;
- providing of pipe integrity and flow area;
- corrosion and erosion protection;
- welding and non-destructive testing during production and installation;
- diagnostics and monitoring;
- process conditions of transferring hydrocarbons and other media at high internal pressure;
- strength and stability of cylindrical sheaths of pipelines, bends and fittings;
- other technological and environmental aspects (refer to Fig. 2.4).

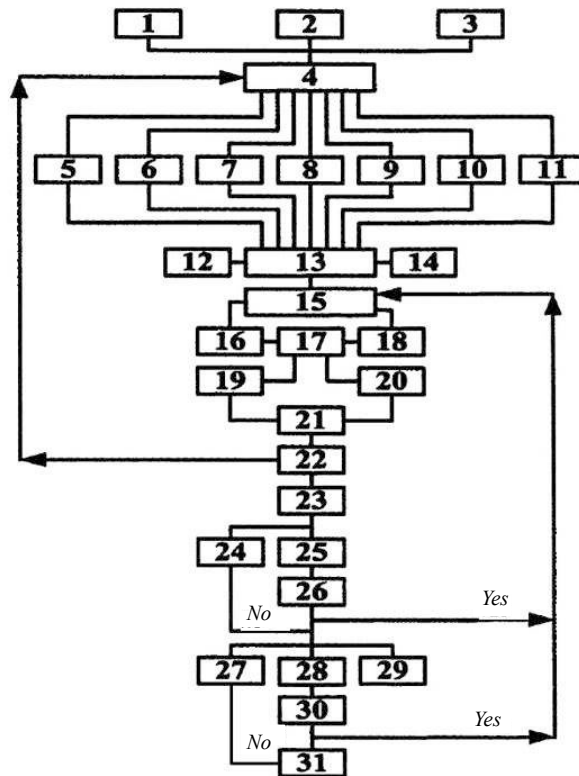

Fig. 2.4 General principles of designing subsea pipelines [13]:

- 1 — conditions of water area; 2 — rules and regulations; 3 — initial design data;
- 4 — technical and economic indicators of pipeline; 5 — construction and installation; 6 — process conditions;
- 7 — flow diagram; 8 — axial section; 9 — routing; 10 — construction monitoring; 11 — service;
- 12 — environmental parameters; 13 — hazards; 14 — economic activities in water area; 15 — risk analysis;
- 16 — probabilities; 17 — risk; 18 — damage; 19 — environmental damage; 20 — damage to process operations;
- 21 — risk criteria; 22 — introduction of amendments to design; 23 — laying requirements;
- 24 — selection of protective soil layer over pipeline; 25 — non-buried pipeline; 26 — natural burial;
- 27 — temporary storage of soil; 28 — construction of trench; 29 — washout; 30 — natural washout; 31 — backfilling

All the issues specified above shall be reflected in the regulatory and technical instruments (regulations, norms, rules, standards, guidelines, instructions, etc.). However, as the practice of design shows, this is not always the case and is explained by the following:

.1 design standards reflect the already accumulated and analyzed experience in the design, construction and operation of pipelines. Introduction of new technologies, expansion of the range of operating parameters, construction in unique natural and climatic conditions, use of new materials and equipment require continuous introduction of amendments to regulatory documentation that occur in practice, but only after accumulation and generalization of relevant experience;

.2 some issues are rather difficult for specifying simple engineering methods or there are no national and foreign references related to these issues (e.g. calculation of stress-strain state of the pipeline sheath during laying to great depths);

.3 many technical solutions do not have rigorous scientific substantiation and require special-purpose, theoretical and experimental studies.

However, even very well-studied issues (e.g. calculating the wall thickness of a pipeline for the effect of internal pressure) cannot be considered resolved. The standards of different countries provide for the use of different values of the same coefficients (reliability and safety factors) in similar design models, which occur due to different approaches to assessing the most appropriate level of safety, quality of pipe manufacture, construction works, operation specifics and cost parameters.

This issue becomes more relevant when there is a need or opportunity to select one or another foreign design standards due to the lack of national regulatory documents (e.g. during design of the offshore section of the Russia — Turkey gas pipeline under the Blue Stream Project in 1998 — 2000). The feasibility study for the construction of the gas pipeline was carried out based on the DNV Rules for Subsea Pipeline Systems, 1981. In 1996, a new edition of these rules, which provided the basis of the basic and detailed design of the offshore section of the gas pipeline was issued.

At the same time, deviations from regulatory design methods imposes additional responsibility on the designer for the correct decision made and requires conducting special studies to determine the actual levels of reliability, safety, durability and other parameters of these critical engineering structures [13].

2.5 SPECIFICS OF MULTIPHASE SUBSEA PIPELINE DESIGN

2.5.1 Subsea pipelines are the integral part of the offshore oil and gas field facilities, since the well fluid transportation (or already prepared products depending on the adopted technological scheme) to the onshore facilities and offloading terminals is performed by pipeline transportation (refer to 2.1-2). An exception to this is, for example, the development of the Prirazlomnoye oil field on the shelf of the Pechora Sea, where all the processes — drilling, oil production, storage, oil offloading to tankers and re-injection into injection wells are carried out from the Prirazlomnaya ice-resistant stationary platform located in 80 km from the coastline, with a design production level of 5 million tons per year of oil offloaded to tankers.

Many offshore field development projects include multiphase well fluid pipelines, which are the main pipeline transportation facilities since other pipelines (gas-lift or water pipelines) are auxiliary. Generally, such pipelines are in operation not from the first years of field operation, but after the established terms for changeover to a mechanized production method using gas lift and the need to increase the well fluid pressure by re-injecting water.

Selection of such an alternative of the well fluid transportation is also determined by economic feasibility, since it reduces the cost of the offshore platform construction in connection with the transfer of the main oil and/or gas treatment operations to the onshore facilities.

The field development project, in accordance with which a set of technological and technical measures will be implemented for the rational use of a subsoil sites for hydrocarbon extraction, is developed in addition to the sections specified in 2.3.1 related to linear and other offshore field facilities, e.g. offshore fixed platforms. A field development project shall be approved by a committee established by the Federal

Subsoil Resources Management Agency, and is not subject to review by the Register. General requirements for a field project development are specified in GOST 32359-2013 [19]. For determining operation modes of an offshore field subsea pipeline system, special attention shall be paid to the following:

- performance of drilling operations, methods of well fluid penetration and well development;
- in-field production and well production system;
- well fluid pressure maintenance system.

Thus, thermal and hydraulic calculations shall be carried out in the process of designing a multiphase subsea pipeline, to determine the most appropriate parameters for well fluid transportation. Technological indicators of field development for maximum oil and/or gas production and the physical and mechanical properties of oil, gas and water, which are accepted in accordance with a field development project, are assigned as initial data.

For gas fields, to avoid formation of liquid plugs, which may prevent pipeline and shore oil/gas and condensate treatment facilities from normal operation, conditions shall be established to ensure uninterrupted multiphase flow. In such case, special attention shall be paid to transitional modes of pipeline operation under the conditions of variable temperature-pressure and flow parameters.

2.5.2 Hydraulic calculations of a multiphase pipeline shall be carried out considering production indicators, physical and chemical properties of oil, gas and water, as well as rheological properties of the transported products of deposits in winter and summer periods.

Thermal and hydraulic calculations of pipelines are performed based on the following initial data:

- field development indicators of year-by-year operation (annual production of oil, condensate, water, and gas at the deposits under development);
- technical conditions for the connection of a multiphase pipeline to the facilities;
- composition and properties of the transported media (component composition of oil, condensate, water, gas from the deposits under development; their physical and chemical properties; gas factor and water cut in wells; flow rates of oil, condensate, water, gas in wells);
- values of wellhead pressure in wells;
- initial temperature of the products in wells;
- minimum and maximum temperature of seabed soil in winter and summer periods accordingly;
- design parameters of the pipeline (diameter and wall thickness of pipes, length, availability of insulation coatings, location on the seabed soil).

2.5.3 Upon calculation results for a multiphase pipeline with specified design parameters transporting well fluid from all production wells the following shall be specified according to each year of operation:

- oil, condensate, water and gas flow rates;
- water cut;
- initial pressure and temperature (for winter and summer periods);
- end pressure and temperature (for winter and summer periods);
- product transportation velocity (for winter and summer periods).

2.5.4 Multiphase pipelines transport a complex, constantly changing mixture of reservoir hydrocarbon fluids and other gaseous, liquid, and solid jointly flowing substances with different flow rates. The main approach to the simulation of hydrodynamic regimes in multiphase pipelines is the model of two fluids, from which it follows that the flow consists of two phases — as a rule, liquid and gas [14]. For such a model of a two-phase gas-liquid flow, four main hydrodynamic flow regimes are possible (refer to Fig. 2.5.4-1).

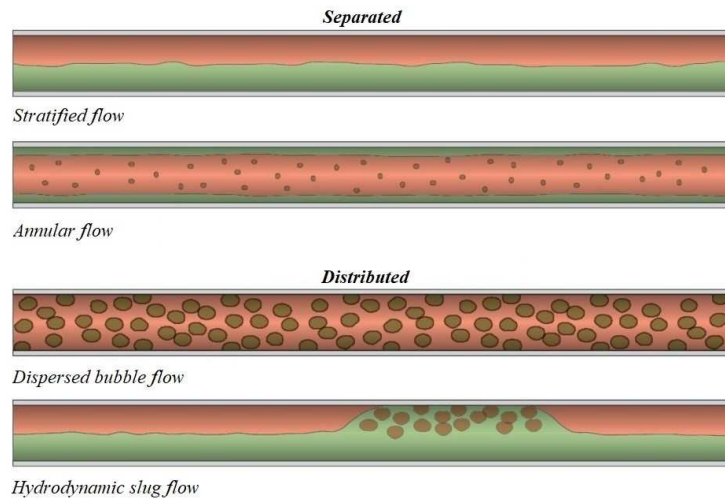

Fig. 2.5.4-1 Main hydrodynamic regimes of two-phase gas-liquid flow [14]

Simplified standard solutions for two-phase gas-liquid flows are the so-called flow pattern maps (diagrams), i.e. horizontal flows, introduced by various researchers based on solutions of the equations of continuum mechanics, e.g. Mandhane flow pattern map (refer to Fig. 2.5.4-2).

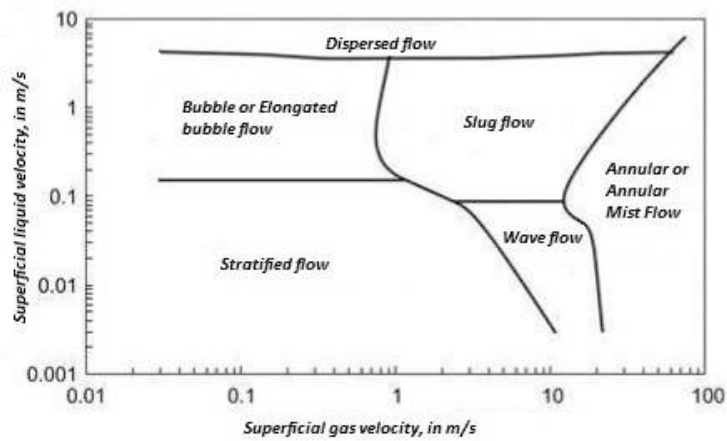

Fig. 2.5.4-2 Mandhane flow pattern map [15]

The superficial velocities of liquid or gas specified in the diagram are determined as the ratio of the liquid or gas volumetric flow rate to the total pipeline cross-sectional area according to the following formulae [15]:

$$U_{sl} = Q_l / A_f; \tag{2.5.4-1}$$

$$U_{sg} = Q_g / A_f \tag{2.5.4-2}$$

where U_{sl} = liquid superficial velocity, in m/s;
 U_{sg} = gas superficial velocity, in m/s;
 Q_l and Q_g = liquid and gas volumetric flow rate respectively, in m³/s;
 A_f = pipeline flow cross-sectional area, in m².

The currently applied software systems for modeling the movement of multicomponent fluid flows in pipelines provide a complete set of empirical and mechanistic methods for analyzing phenomena arising from the movement of multiphase fluid through pipes. For example, PIPEPHASE [16] contains a developed library of media parameters for simulating steady-state multiphase flows, and calculates the energy balance and thermodynamic characteristics. PIPEPHASE allows comprehensive modelling of oil and gas gathering and transporting networks for the field.

Schlumberger's PIPESIM 2017.2 software also offers modern modeling techniques for steady-state multiphase flow. This software allows performing calculations of a set of hydrodynamic conditions that make it difficult to optimize production: from the deposition of asphaltenes, wax and hydrates to carbon dioxide corrosion and erosion caused by the flow [14].

The OLGA software developed by Norwegian company SPT Group is among the most widely used dynamic multiphase flow simulators [14].

REFERENCES

1. Procedures of Laying of Submarine Cables and Pipelines in Internal Seawaters and Territorial Sea of the Russian Federation approved by the Resolution of the Government of the Russian Federation No. 68 of January 26, 2000.
2. Administrative regulations of the Federal Service for Supervision of Natural Resources (Rosprirodnadzor) for providing of state services for issuing permits for laying of subsea cables and pipelines in internal sea waters, territorial sea of the Russian Federation and on continental shelf of the Russian Federation approved by Order of the Ministry of Natural Resources No. 202 of June 29, 2012.
3. Law of the Russian Federation No. 2395-I of February 21, 1992 "On Subsoil".
4. Town-planning Code of the Russian Federation No. 190-FZ of December 29, 2004.
5. Resolution of the Government of the Russian Federation No. 87 of February 16, 2008 "Regulations on Composition of Design Documentation Sections and Requirements for Their Content".
6. Federal Law No. 116-FZ of July 21, 1997 "On Industrial Safety of Hazardous Production Facilities".
7. Federal Law No. 155-FZ of July 31, 1998 "On Internal Sea Waters, Territorial Sea and Contiguous Zone of the Russian Federation".
8. RD 11-02-2006 Requirements for the Composition and Procedure for Maintaining As-Built Documentation During Construction, Reconstruction, Overhaul of Capital Construction Facilities and Requirements for Acts of Examination of Works, Structures, Sections of Utilities.
9. SP 11-110-99 Architectural Supervision of the Construction of Buildings and Structures.
10. Vasiliev G.G., Goryainov Yu.A., Bespalov A.P. Construction of Offshore Pipelines. Moscow, Gubkin Russian State University of Oil and Gas, 2015.
11. Pipeline Transport of Highly Viscous and High-Melting Oil and Oil Products/N.A. Swarovskaya. Preparation, Transport and Storage of Well Products, Tomsk, Ed. TPU, 2004.
12. Yong Bai Subsea Pipelines and Risers, Elsevier Science, 2010.
13. Sea Oil. Pipeline Transport and Well Products Processing/Ed. A.M. Shammazov. — Saint-Petersburg: Nedra, 2006.
14. Multiphase Flow Simulation — Optimizing Field Productivity, Oilfield Review (Winter 2014/September 2015).
15. Offshore Pipelines: Design, Installation, and Maintenance, 2nd Edition. — Oxford: Gulf Professional Publishing, 2014.
16. PIPEPHASE Multiphase Flow in Networks, Schneider Electric Software, LLC.
17. Papusha A.N., Kazunin D.V. Dynamics of Multiphase Flow in Marine Pipelines (Institute Of Computer Science, Moscow, 2012.
18. Mansurov M.N., Lapteva T.I. Problems of Reliability and Repair of Subsea Pipelines for Oil and Gas Transport at Continental Shelf Development — Oil and Gas Territory, 2013.
19. GOST 32359-2013 Oil and Gas-Oil Fields. Rules for Reservoir Engineering.

3 GEOLOGICAL SURVEY

3.1 PROCEDURE AND DESCRIPTION OF SURVEY ALONG PIPELINE ROUTE

The average frequency of accidents at offshore pipelines is 0,3 — 0,4 accidents/year per 1000 km. The main causes of the accidents are corrosion of pipe metal (50 %), mechanical damage due to exposure to anchors, trawl boards, service vessels and barges (20 %) and natural processes (12 %) [18].

Among the accidents that caused by natural processes, it is necessary to specify accidents occurred as a result of geological processes (geological hazards), which pose a threat to the integrity of subsea pipeline structure (earthquakes, landslides, avalanches, turbid flows, exaration). Statistical data on the frequencies of hazardous initiating events is provided in [4].

Subsea systems are safer as compared to the production and preparation processes using permanently manned surface facilities (floating offshore oil-and-gas production units, platforms) from the point view of influence on the attending personnel. However, there are restrictions on the use of subsea production systems (SPS) in shallow waters of the freezing seas due to the possible damage to the underwater systems caused by hummock ridges and the difficulty to carry out maintenance and repair of facilities during the freeze-up period.

At the initial stages of engineering and geological study of the water area, a route or site is selected for construction of offshore installations [5], [14].

According to ISO 13623: 2017 [12], it is recommended to select and study the following geological hazards to select the safest route of the pipeline:

- earthquakes and their secondary effects (soil liquefaction, landslides, etc.);
- areas of highly dissected relief;
- landslide-hazardous areas of seabed;
- soil erosion;
- sediment migration;
- subsidence;
- weak bottom sediments;
- gas saturation of soil;
- abrasion.

In accordance with GOST R 54382-2011 [1] the following geological hazards are subject to study: earthquakes, soil liquefaction, seabed instability, turbid flows, erosion, subsidence, exaration, sea sediment growth, sand waves, rock outcrops, sediment accumulation, deep hollows.

According to STO Gazprom 2-3.7-576-2011 [13] geological hazards include the following: earthquakes, landslides, avalanches, mud streams, seabed subsidence, permanently frozen ground, gas-saturated and gas-hydrate-saturated soils, exaration, abrasion, migration of bottom sediments, boulders, rock outcrops.

In accordance with [7], when designing offshore pipeline systems, it is necessary to take into account such geological features and phenomena as very weak soils, mobile sand waves, boulder fields, exaration gouges (plow marks), coral rocks, pockmarks (conical crater-like depressions on the seabed surface resulting from incidental gas seepage) and gas vents.

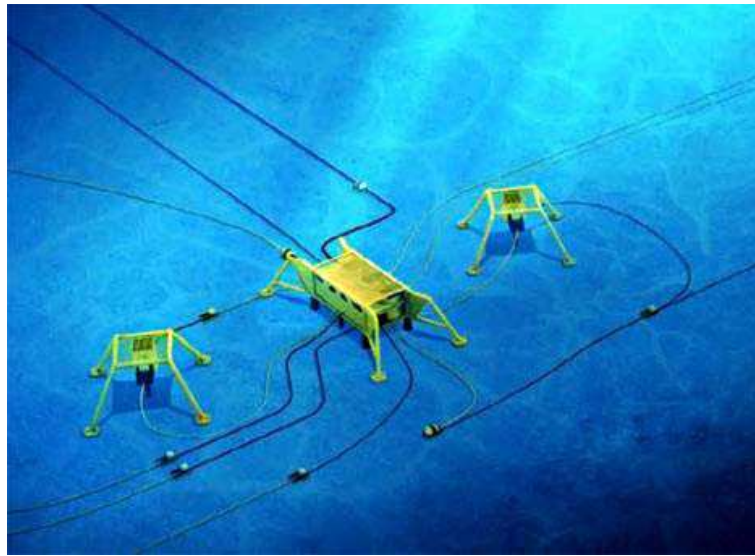

Fig. 3.1 Subsea production system (SPS) and subsea pipelines: manifold, production wells with subsea wellhead and protective structures and subsea pipelines [2]

3.2 GENERAL REQUIREMENTS FOR ENGINEERING AND GEOLOGICAL SURVEY

Engineering and geological surveys along the subsea pipelines routes is carried out in order to study the geological structure of seabed soils with engineering geological columns and profiles being plotted, statistical analysis performed using soil laboratory study results, standard and design characteristics of soils determined, design model of foundation soil constructed.

The sequence and procedure of the work performance are the following:

1. Engineering survey:
 - .1 drilling and sampling of seabed soils;
 - .2 navigation support;
 - .3 laboratory study of seabed soils;
 - .4 procedures for determining the physical properties of seabed soils;
2. Structure, composition and properties of seabed soils:
 - .1 structure of foundation soil profile;
 - .2 composition and physical properties of soils and engineering-geological elements;
 - .3 deformation and strength properties of soils.
3. Drawing up a report on works performed.

3.3 ENGINEERING AND GEOLOGICAL SURVEY ALONG PIPELINE ROUTE

3.3.1 In these Recommendations subsea pipeline route from the fixed offshore platform in the Caspian Sea to the landfall with the total length of the offshore part of the route equal to 145 km is taken as an example (refer to Fig. 1.2). The pipeline parameters are specified in Chapter 1.2 of these Recommendations. The requirements for engineering surveys and seabed soil parameters shall comply with the provisions of 8.2.2, Part I "Subsea Pipelines" of the SP Rules.

3.3.2 The marine engineering survey is carried out in accordance with SP 11-114-2004 [6]. In order to study the geological structure of the upper part of the soil profile, the conditions of soil occurrence depth and to determine their physical and mechanical properties, the seabed soil is sampled to a depth of 4 to 4,8 m and

provision is made for a total of 16 sampling stations along the route. Samples is taken by a vibro-piston core sampler from small hydrographic survey vessel GS-194 following the procedure specified below.

The vessel is navigated to the design sampling point and anchored, after which the bottom frame of the sampler lowered to the bottom at a given point. A vibration mechanism that provided the sampler penetration into soil is switched on using a control panel located on board the vessel.

To preserve the natural moisture content, the undisturbed (monolithic) core samples are immediately paraffined. The disturbed soil samples are sealed immediately in plastic bags.

On the pipeline route, 5 wells (5,9 — 11,6 m) are drilled from the PTS drilling pontoon, which is a catamaran-type non-propelled floating process platform equipped with a drilling derrick, a ZIF-650A drilling rig and anchor winches for positioning at the drilling location. In such case, the cable-tool drilling method is used; the wells are staked taking into account the results of seismic acoustic data interpretation.

The navigation and geodetic support provide for the preliminary planning of the location of sampling and drilling locations in accordance with the requirements of the design specification, as well as the subsequent navigation of the vessel to the target locations.

Field data is processed on board the support ship in accordance with SNiP 11-02-96 [16] and SP 11-114-2004 [6]. All operations for the selection, preservation, transportation and storage of samples (monolithic core samples) for laboratory studies are carried out in accordance with GOST 12071-2000 [17].

3.3.3 Laboratory studies of soils are carried out in accordance with the requirements of the design specification to determine the comprehensive characteristics of their composition, physical and mechanical properties.

The objectives of those studies include the following:

- determination of soil grading and physical properties according to GOST standards;
- determination of soil grading, plasticity limits and plasticity index of soils according to ASTM standards;
- determination of resistivity of soil samples;
- determination of carbonate, organic content and salt content of soil samples;
- rapid determination of undrained soil adhesion;
- determination of soil filtration factor;
- determination of strength and deformation properties of soils when tested in conditions of triaxial compression under static loads;
- determination of statistical characteristics, standard and design values of soil properties.

Results of laboratory studies of soils for wells to determine the composition and physical properties of soils and engineering-geological elements (EGE) according to GOST and ASTM are specified in Tables 3.3.3-1 and 3.3.3-2. In accordance with GOST 25100-95 "Soils. Classification" the following is identified along the route of the gas pipeline under study:

II class of natural dispersed soil:

group — cohesive; subgroup — sedimentary polymineral; type — clay soils; category — clay loam, silt, clay.

group — non-cohesive; subgroup — sedimentary polymineral; type — sandy soils; category — silty, fine, medium, large and gravelly sand.

3.3.4 According to the requirements of 8.2.2, Part I "Subsea Pipelines" of the SP Rules, the studied depth with the soil parameters determined shall be generally 6,0 — 8,0 m taking into account the specified depth of the pipeline in the trench. In case of any silts or soft soils, the drilling depth shall be increased by the depth of their layers. When implementing a subsea pipeline design, upon agreement with the Register, the seabed soil averages based on the previous engineering surveys and/or reference data may be used, provided that appropriate calculations have been performed at the detailed design stage using the soil parameters based on engineering and geological survey.

Particular attention shall be paid to the study of soft soils with bearing capacity insufficient for the safe laying and operation of the pipeline. It generally means under consolidated or normally consolidated, water-saturated silt, shells, peats, clay loams, fluid and fluid-plastic clays (in some cases, dynamically unstable water-saturated silty sands of low and medium density).

Table 3.3.3-1

EGE-2a — gravelly sand, heterogeneous grading, water-saturated, pebbly

Soil property		Unit of measurement	Number of determinations	Standard value	Variation factor	Design value	
						at $\alpha = 0,85$	at $\alpha = 0,95$
Natural moisture content, W		%	26	30,0	0,14		
Moisture level, S_r		unit fraction	—	1,01	—		
Density of soil particles, ρ_s		g/cm ³	26	2,75	0,03		
Density of soil of moisture content, ρ		g/cm ³	19	1,97	0,02	1,96	1,96
Dry soil density, ρ_d		g/cm ³	—	1,52	—		
Porosity factor, e		unit fraction	19	0,81	0,14		
Soil grading at particle size, in mm	1,0 — 0,5	%	26	16,20			
	0,5 — 0,25		26	10,68			
	0,25 — 0,1		26	9,69			
	< 0,1			3,09			
	0,1 — 0,05		20	5,96			
	0,05 — 0,01		20	0,81			
	0,01 — 0,005		20	0,49			
0,005 — 0,001	20	1,21					
Uniformity coefficient, C_u				16,1			

Table 3.3.3-2

EGE-5b — clay soils: flow silty clay sand

Soil property		Unit of measurement	Number of determinations	Standard value	Variation factor	Design value	
						at $\alpha = 0,85$	at $\alpha = 0,95$
Natural moisture content, W		unit fraction	93	28,8	0,11		
Liquid limit, W_L		%	93	23,4	0,11		
Plastic limit, W_P		%	93	18,6	0,12		
Plastic index, I_P		%	93	4,8	0,12		
Liquidity index, I_L		—	—	2,11	—		
Moisture level, S_r		unit fraction	—	0,98	—		
Density of soil particles, ρ_s		g/cm ³	93	2,69	0,02		
Density of soil of moisture content, ρ		g/cm ³	83	1,94	0,03	1,94	1,94
Dry soil density, ρ_d		g/cm ³	—	1,50	—		
Porosity factor, e		—	82	0,79	0,09		
Soil grading at particle size, in mm	1,0 — 0,5	%	42	0,62			
	0,5 — 0,25		45	1,32			
	0,25 — 0,1		45	27,26			
	< 0,1			—			
	0,1 — 0,05		45	43,87			
	0,05 — 0,01		45	8,25			
	0,01 — 0,005		45	3,04			
0,005 — 0,001	45	15,41					
Uniformity coefficient, C_u				27,1			

3.3.5 In general, the construction of the longitudinal profile of the subsea pipeline shall comply with the requirements of GOST 21.610-85 "System of building design documents. Gas supply. Outside gas pipelines. Working drawings". However, the specifics of the pipeline design as a subsea facility and the specific features of its routing including those related to laying it onto/into the seabed soil shall be taken into account. The main parameter, based on which the results of engineering surveys shall be presented, are the depth marks from the sea level including the distribution of seabed soils to the depths of sampling and drilling of design wells. The following is plotted and indicated on the longitudinal profile of the subsea pipeline:

- design deformations of seabed;
- boundaries between identified and expected EGEs;
- contacts between depositional sequences;

- amplitude anomalies;
- areas of probable gas accumulation in seabed soils (if any);
- distance between depth marks;
- staking-out;
- water depth at the design level in the Baltic height system — 28,0 m;
- absolute elevation of seabed surface;
- wave height of 1 % probability;
- average wave period;
- average wave length;
- angle between the normal to the pipeline center line and the direction of current;
- bottom velocity of current with waves of 1 % probability;
- designed pipeline with pipe bottom elevations;
- seabed soil sampling points and their numbers indicating a depth of EGE boundaries (from the seabed surface) and a length of selected soil cores;
- pipeline slope/section length;
- standard sizes of pipes used (technical characteristics of pipe to be laid);
- angles of right-of-way centerline, straight sections;
- length, in km;
- method of laying the pipeline;
- trench development method;
- backfilling method.

3.3.6 Determination of subsidence of offshore pipeline in seabed.

Determination of subsidence values of the subsea pipeline in the seabed is a very important element of the subsea pipeline design since this parameter affects the design values of wave and current effects on the pipeline, and, in some cases (in case of soft soils), the pipeline strength. The initial data are the Young's moduli and Poisson's ratios of the layers (transverse deformation), and their thicknesses. A depth of the lower underlying layer is not specified. Resulting characteristics C_1 and C_2 are the soil bearing (stiffness) ratio of the elastic base at compression and shear respectively.

The calculation results for the pipeline under consideration (refer to Fig. 1.2) with the soil properties according to Tables 3.3.3-1 and 3.3.3-2 are specified in Fig. 3.3.6 and Table 3.3.6. According to the calculation results based on procedure specified in 3.3.7, the obtained subsidence is within the allowable values, which may be taken as the allowable pipeline buckling provided that its strength is ensured.

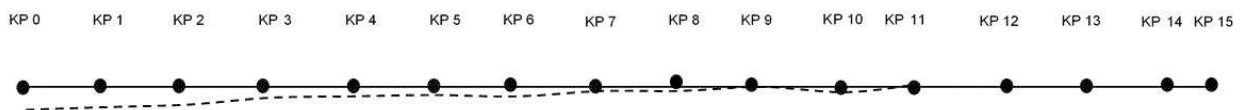

Fig. 3.3.6 Subsidence of subsea pipeline

Table 3.3.6

Values of subsea pipeline subsidence

KP, No.	Area, No.	C_1 , in kN/m ³	C_2 , in kN/m	Subsidence, in cm
0	0 — 1	3479	231	11,5
1	1 — 2	3479	231	10,5
2	2 — 3	3475	231	10,0
3	3 — 4	3469	231	8,0
4	4 — 5	3460	231	6,0
5	5 — 6	3440	231	4,5
6	6 — 7	3430	230	4,2
7	7 — 8	3418	230	3,5
8	8 — 9	3418	230	2,5
9	9 — 10	3400	230	1,5
10	10 — 11	3350	229	1,0
11	11 — 12	3316	229	1,0
12	12 — 13	3274	229	0,75
13	13 — 14	3274	229	0,5
14	14 — 15	3159	228	0,0
15		0,0		

3.3.7 Strength assessment of foundation soil along pipeline route.

In accordance with 8.2.2, Part I "Subsea Pipelines" of the SP Rules, the geological engineering surveys shall obtain the necessary design characteristics of the soils taking subsea pipeline load for calculations of the following:

- subsidence and consolidation of the foundation soil;
- local contact stresses (if required);
- arranging trenches or soil stabilization;
- dynamic stability of soils under seismic, wave and ice loads.

The purpose of calculation the foundations for deformations is to restrict absolute or relative displacements to the limits, within which the normal operation of a subsea pipeline is ensured and its operational parameters are not reduced due to unacceptable total and non-uniform subsidence, rises, inclinations, changes in design levels and positions of structures, distortion of their joints, etc.). In this case, the strength of subsea pipeline is verified by calculation considering the forces that arise when the pipeline interacts with the foundation soil.

According to 5.6.5 of SP 22.13330.2011 [10], the calculation of the foundation for deformations is performed based on the following:

$$s \leq s_u \tag{3.3.7-1}$$

where

s = subsidence of foundation base (combined deformation of base and structure);

s_u = limit subsidence of foundation base (combined deformation of base and structure) established in accordance with 5.6.46 — 5.6.50 [10].

The design model of the base used to determine the combined deformation of the base and structure shall be selected in accordance with 5.1.6 [10]. Given average pressure p under the foundation bed not exceeding design soil resistance R (refer to 5.6.7 [10]), the deformations of the foundation base shall be calculated using a design model in the form of a linearly elastic semi-space (refer to 5.6.31 [10]) with the conditional limitation of depth H_c of the compressed layer (refer to 5.6.41 [10]).

For preliminary deformation calculations of the foundation bases for the structures of consequence classes II and III at average pressure p under the foundation bed not exceeding design soil resistance R (refer to 5.6.7 [10]), the design model in the form of a linearly elastic layer (refer to Appendix D [10]) may be used.

Using the design model in the form of a linearly elastic semi-space (refer to 5.6.6 [10]), foundation base subsidence s , in cm, is determined by the layer-by-layer summation method according to the formula

$$s = \beta \sum_{(i=1)}^n (\sigma_{zp,i} h_i) / E_i \quad (3.3.7-2)$$

where $\beta = 0,8$ — dimensionless factor;

$\sigma_{zp,i}$ = average value of vertical normal stress (hereinafter referred to as "the vertical stress") from the external load in the i -th layer of soil along the vertical that passes through the center of the foundation base (refer to 5.6.32 [10]), in kPa;

h_i = thickness of the i -th layer of soil, in cm, that is taken no greater than 0,4 times the foundation width;

E_i = deformation modulus of the i -th layer of soil along the primary loading branch, in kPa;

n = number of layers, into which the compressed layer of the base is broken down.

Distribution pattern of vertical stresses in a linearly elastic semi-space is provided in Fig. 3.3.7.

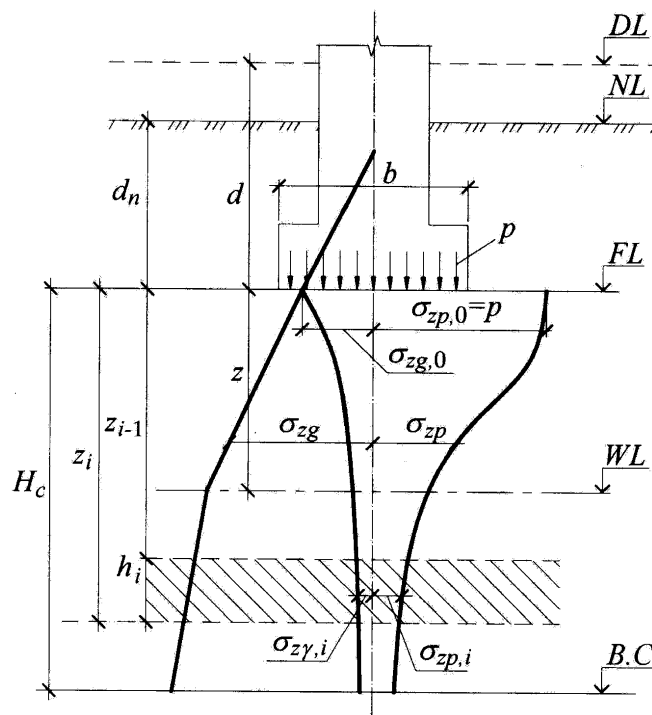

Fig. 3.3.7 Vertical stress distribution pattern in linearly elastic semi-space

The strength of the foundation soil (subsea pipeline foundation soil, including in trench) is also checked by determining the design resistance of the base soil. In accordance with 5.6.7 [10] when calculating the deformations of the foundation bases using the above design models, average pressure p under the foundation bed shall not exceed the design resistance R of the base soil determined by the formula

$$R = \frac{\gamma_{c1}\gamma_{c2}}{k} [M_{\gamma} b \gamma_{II} + M_q d_1 \gamma'_{II} + M_c c_{II}] \quad (3.3.7-3)$$

where γ_{c1} and γ_{c2} = service factors (refer to Table 5.4, [10]);

k = factor taken $k = 1$ if the soil strength properties (φ_{II} and c_{II}) are determined by direct tests, and $k = 1,1$ if soil strength properties are taken according to Appendix B [10];

M_{γ} , M_q , M_c = factors taken according to Table 5.5 [10];

b = width of foundation bed, in m (for the case considered, may be taken equal to the external diameter of the pipeline with coatings);

d_1 = foundation depth, in m (for the case considered, is taken equal to the value of subsea pipeline subsidence or the value of the trench depth);

γ_{II} = design specific weight (averaged in accordance with 5.6.10 [10]) of soils lying underneath the foundation bed, in kN/m^3 ;

γ'_{II} = design specific weight (averaged in accordance with 5.6.10 [10]) of soils lying above the foundation bed, in kN/m^3 ;

c_{II} = design specific cohesion of the soil lying directly under the foundation bed (refer to 5.6.10 [10]), in kPa.

The strength of the base may be determined using soil bearing ratio C_1 , which is calculated from the averaged values of the deformation modulus E_{soil} and the Poisson's ratio (transverse deformation) of soil ν determined according to Table 5.10 [10]:

$$C_1 = \frac{E_{soil}}{H_c(1-2\nu^2)}. \quad (3.3.7-4)$$

Soil bearing ratio C_2 is determined by the following formula:

$$C_2 = \frac{C_1 H_c^2 (1-2\nu^2)}{6(1+\nu)}. \quad (3.3.7-5)$$

Set of issues related to pipe and foundation soil interaction with subsea pipeline is sufficiently detailed in [19].

REFERENCES

1. GOST 54382-2011 Submarine Pipeline Systems. General Requirements.
2. Mironyuk S.G. Analysis of Geological Hazards and Risks in Construction of Offshore Pipelines and Subsea Production Complexes. Engineering protection, No.11, 2015.
3. Borodavkin P.P. Soil Mechanics in Pipeline Construction. Moscow: Nedra, 1986;
4. Onishchenko D.A. Risks Associated with Use of Subsea Technologies in Development of Shallow-Water Offshore Fields of the Obiskaya and Tazovskaya Bays//D.A. Onishchenko, I.E. Ibragimov, V.M. Nazerov. Development of Offshore Oil and Gas Fields: Status, Problems and Prospects: Proceedings Moscow, 2008.
5. Handbook on Engineering Survey for Design and Construction of Gas Pipelines on Shelf. Gazprom JSC. Moscow, 1996.
6. SP 11-114-2004 Engineering Survey on Continental Shelf for Construction of Offshore Oil and Gas Field Facilities//Gosstroy of Russia. Moscow: FGUP PNIIS, Gosstroy of Russia, 2004.
7. Rules and Guidelines Industrial Services. IV-Part 8. Pipelines. Chapter 1. Rules for Subsea Pipelines and Risers. Germanischer Lloyd Offshore and Industrial Services GmbH, 2004.
8. DNVGL-ST-F101 Submarine Pipeline System, 2017.
9. Recommendations on Composition and Organization of Pre-Investment Research in Gazprom JSC, 2008.
10. SP 22.13330.2011 Foundations of Buildings and Structures (Revised edition of SNiP 2.02.01-83).
11. ISO 19906: 2019 Petroleum and Natural Gas Industries. Arctic Offshore Structures.
12. ISO 13623:2017 Petroleum and Natural Gas Industries. Pipeline Transportation Systems.
13. STO Gazprom 2-3.7-576-2011 Design, Construction and Operation of Subsea Production Systems.
14. Astafyev S.V., Kalinin E.N. Polomoshnov A.M., Surkov G.A. Problems of the Choice of the Route of the Subsea Pipeline in the Conditions of the Shelf of Sakhalin Island.//Nature Protection, Monitoring and Arrangement of the Sakhalin Shelf. Yuzhno-Sakhalinsk. 2001, p.143-150.
15. Mironyuk S.G., Otto V.P. Gas-Saturated Marine Soils and Natural Hydrocarbon Gas Emission: Patterns of Distribution and Hazard to Engineering Structures. — Georisk, 2014, No. 2.
16. SP 47.13330.2016 (Revised edition of SNiP 11-02-96) Engineering Survey for Construction. General Provisions, 2016.
17. GOST 12071-2000 Soils. Selection, Packaging, Transportation and Keeping of Samples.
18. Samuseva E.A. Analysis of Danger of Offshore Pipelines to Quantitative Assessment of Risk of Accidents. STC of Industrial Safety Problems Research, 2011.
19. DNVGL-RP-F114 Pipe-Soil Interaction for Submarine Pipelines, 2017.

4 DESIGN LOADS ACTING ON SUBSEA PIPELINE

4.1 GENERAL REQUIREMENTS FOR DESIGN LOADS

The design loads (without taking into account accidental and emergency loads, external effects of third parties) acting on the subsea pipeline shall include external loads depending on the operating conditions, test loads and loads during pipeline installation. Design loads include the following:

- pipeline weight (in water and in air);
- internal pressure of transported medium;
- external water pressure with regard to water level changes due to tides and waves;
- seismic loads;
- current loads;
- wave loads;
- temperature effects.

According to 2.1.1, Part I "Subsea Pipelines" of the SP Rules, the design value of each of the above loads shall be multiplied by appropriate significance factor of load components $\gamma \geq 1,0$ taking into account the accuracy of determining any given design load and the stability of its action (refer to Table 4.1.1).

Table 4.1.1

Significance factors of load components γ

Type of load	γ
Weight of pipeline and auxiliary structures	1,1
Internal pressure:	
for gas pipelines	1,1
for oil- and petroleum product pipelines	1,15
External water pressure with regard to water level changes due to tides and waves	1,1
Pipeline crowning/burial soil pressure in trench	1,4
Pipeline icing in case the media with temperature below zero are transported	1,4
Seismic	1,1
Current	1,1
Wave	1,15
Wind (for above-water sections)	1,1
Temperature	1,0

4.2 DESIGN PRESSURE

Design pressure in the pipeline p_0 , in MPa, is determined according to 2.2, Part I "Subsea Pipelines" of the SP Rules (numerical values of the parameters correspond to the sample calculation specified above):

$$p_0 = (p_i - p_{g \min}) + \Delta p = 8,0 \text{ MPa} \quad (4.2-1)$$

where $p_i = 8,0 \text{ MPa}$ — internal operating pressure in the pipeline;

$p_{(g \min)}$ = minimum external hydrostatic pressure on the pipeline, in MPa;

Δp = additional design pressure, in MPa, taking account of touch-up pressure of the transported medium in the pipeline and/or pressure of a hydraulic impact in the pipeline, which is characteristic for pipelines transporting fluid or two-phase medium. When transporting gaseous media, the design pressure is taken to be equal to the maximum working pressure ($\Delta p = 0$).

The minimum external hydrostatic pressure on the pipeline depends on a depth of the water area and wave characteristics (hereinafter, the numerical values of the parameters are specified for the design case under consideration) and is determined by the following formula:

$$p_{g \min} = \rho_w g (d_{\min} - h_w / 2) 10^{-6} = 1010 \cdot 9,8 (9,6 - 4,9 / 2) 10^{-6} = 0,071 \text{ MPa} \quad (4.2-2)$$

where $\rho_w = 1010 \text{ kg/m}^3$ — density of sea water;
 $g =$ gravity acceleration, in m/s^2 ;
 $d_{\min} = 9,6 \text{ m}$ — the lowest still water level along the pipeline route, in m, taking into account tides and storm surge effects with 10^{-2} 1/year probability;
 $h_w = 4,9 \text{ m}$ — design wave height on the pipeline design section, in m, with 10^{-2} 1/year probability.

Where the value of the minimum external hydrostatic pressure on the pipeline (due to changes in water level and wave height) is not exceeding 0,1 MPa (in this case, 0,071 MPa), it may not be taken into account in the design pressure.

4.3 DETERMINATION OF LOADS DUE TO EFFECTS OF CURRENTS AND WAVES

The loads due the effects of currents and waves (the latter shall be taken into account at depths approximately equal to or smaller than the wave lengths) for the pipelines not buried into the seabed soil shall be determined based on the engineering survey data, which, among other things, shall provide the direction of the currents and the so-called wave-hazardous directions (directions of the wave front) for the pipeline route or its individual sections (refer to Fig. 4.3.1-1).

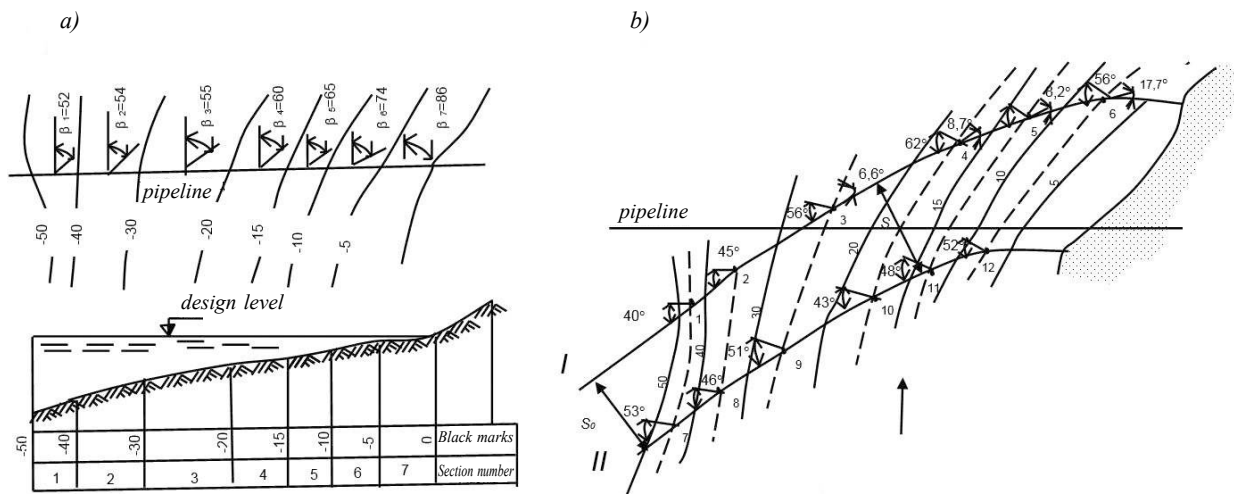

Fig. 4.3.1-1 Design model to determine components of force impact on pipeline:
 a — current effect pattern; b — chart of wave front propagation

To determine the design loads due to the effects of current and waves, the direction of their action depending on a section of the pipeline route shall be determined. The direction of the current and wave velocities relative to the sections between KPs of the pipeline route, as well as an angle between the velocity vector and the normal to the pipeline in the specified section is provided in Fig. 4.3.1-2.

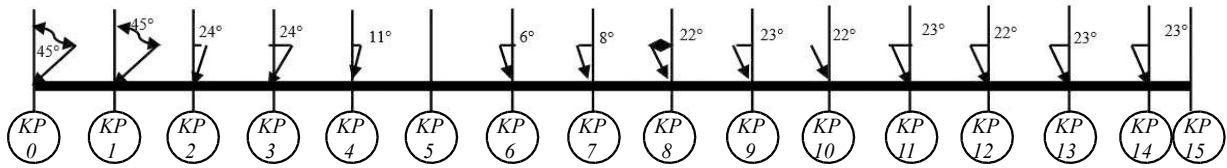

Fig. 4.3.1-2 Direction of current/wave velocities relative to sections of subsea pipeline route

The data on the direction of current/wave velocity relative to sections of subsea pipeline route is specified in Table 4.3.1-1.

Table 4.3.1-1

Direction of current/wave velocities relative to sections of subsea pipeline route

KP, No.	0	1	2	3	4	5	6	7	8	9	10	11	12	13	14	15
Angle, deg.	45	45	24	24	11	0	15	15	27	27	27	27	27	27	27	0

Values of linear loads: horizontal $F_{c,h}$, vertical $F_{c,v}$ and total F_c due to current, in N/m, are determined by the following formulae:

$$F_{c,h} = c_x \frac{\rho_w V_c^2}{2} D_a; \quad (4.3.1-1)$$

$$F_{c,v} = c_z \frac{\rho_w V_c^2}{2} D_a; \quad (4.3.1-2)$$

$$F_c = \sqrt{F_{c,h}^2 + F_{c,v}^2} \quad (4.3.1-3)$$

where $V_c = 0,68$ m/s — design current velocity projected on the normal to the pipeline axis at the depth of pipeline installation, in m/s, and determined for the given geographical region with 10^{-2} 1/year probability based on the engineering survey;

c_x, c_z = pipeline resistance factors;

D_a = pipeline outside diameter, in m.

According to 2.5.2, Part I "Subsea Pipelines" of the SP Rules, resistance factor c_x of a pipeline lying on the seabed is determined from the diagram in Fig. 4.2.1-3 proceeding from the Reynolds number Re and the relative roughness of external pipe surfaces (corrosion protection or weight coating), which is determined by the following formula (numerical values of the parameters correspond to the sample calculation specified above):

$$Re = V_c D_a / \nu = 0,68 \cdot 0,35 / 1,2 \cdot 10^{-6} \approx 2 \cdot 10^5 \quad (4.3.1-4)$$

where $\nu = 1,2 \cdot 10^{-6}$ m²/s — kinematic water viscosity;

c_z = resistance factor of pipeline lying on seabed;

ρ_w = sea water density, in kg/m³;

D_a = pipeline outside diameter, in m.

In addition, the values of pipeline resistance factors c_x and c_z depend on the position of the pipeline relative to the seabed (refer to 2.5.3, Part I "Subsea Pipelines" of the SP Rules).

The calculation results of the loads acting on the sections between KPs along the route of the non-buried subsea pipeline due to current are provided in Table 4.3.1-2.

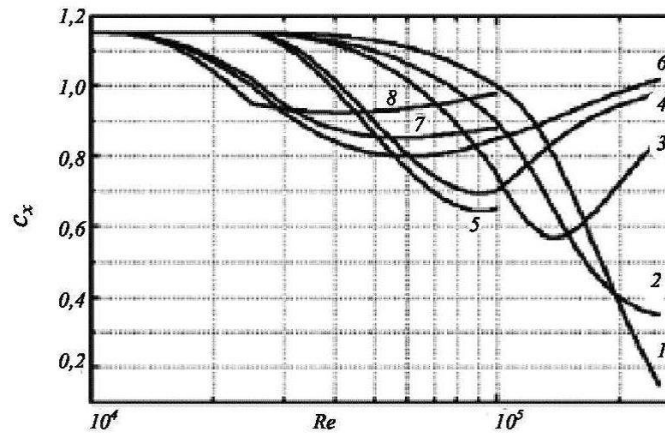

Fig. 4.3.1-3 Diagram of dependence of factor c_x on Reynolds number and relative roughness k of pipeline surface:
 1 — $k = 0$; 2 — $k = 5,0 \cdot 10^{-4}$; 3 — $k = 2,0 \cdot 10^{-4}$; 4 — $k = 4,0 \cdot 10^{-3}$; 5 — $k = 5,0 \cdot 10^{-3}$; 6 — $k = 7,0 \cdot 10^{-3}$;
 7 — $k = 9,0 \cdot 10^{-3}$; 8 — $k = 2,0 \cdot 10^{-2}$

Table 4.3.1-2

Loads acting on subsea pipeline due to current

KP, No.	α , in deg.	$\cos \alpha$	$V \cos \alpha$, in m/s	c_x	c_z	$F_{c,h}$, in N/m	$F_{c,v}$, in N/m	F_{c} , in N/m
0	45	0,707	0,481	0,4	0,8	16,341	32,682	36,539
1	45	0,707	0,481	0,4	0,8	16,341	32,682	36,539
2	24	0,914	0,622	0,4	0,8	27,310	54,621	61,068
3	24	0,914	0,622	0,4	0,8	27,310	54,621	61,068
4	11	0,999	0,679	0,4	0,8	32,626	65,253	72,955
5	0	1,000	0,680	0,4	0,8	32,692	65,383	73,101
6	15	0,966	0,657	0,4	0,8	30,506	61,013	68,214
7	15	0,966	0,657	0,4	0,8	30,506	61,013	68,214
8	27	0,891	0,606	0,4	0,8	25,953	51,907	58,033
9	27	0,891	0,606	0,4	0,8	25,953	51,907	58,033
10	27	0,891	0,606	0,4	0,8	25,953	51,907	58,033
11	27	0,891	0,606	0,4	0,8	25,953	51,907	58,033
12	27	0,891	0,606	0,4	0,8	25,953	51,907	58,033
13	27	0,891	0,606	0,4	0,8	25,953	51,907	58,033
14	27	0,891	0,606	0,4	0,8	25,953	51,907	58,033
15	0	1,000	0,680	0,4	0,8	32,692	65,383	73,101

Horizontal linear wave load $F_{w,h}$, in N/m, on the pipeline is determined by the formula

$$F_{w,h} = \sqrt{F_{w,z}^2 + F_{w,i}^2} \quad (4.3.1-5)$$

where $F_{w,z}$ = linear load due to resistance forces, in N/m;

$$F_{w,z} = c_d \frac{\rho_w V_w^2}{2} D_a; \quad (4.3.1-6)$$

$F_{w,i}$ = linear load due to inertia forces, in N/m;

$$F_{w,i} = c_i \frac{\pi \rho_w a_w}{2} D_a^2; \quad (4.3.1-7)$$

V_w = design wave particle velocity projected onto the normal to the pipeline axis at the depth of pipeline installation, in m/s (refer to Appendix 1 to this Section);

a_w = wave particle acceleration projected onto the normal to the pipeline axis at the depth of pipeline installation, in m/s^2 (refer to Appendix 1 to this Section);

ρ_w, D_a = determined in accordance with Formulae (4.3.1-1) — (4.3.1-4);

c_d, c_i = resistance factors of undulatory motion of water particles.

Depending on their design characteristics, parameters of the subsea pipeline and its route, the loads due to the combined effects of waves and currents are determined in accordance with 2.6, Part I "Subsea Pipelines" and Appendix 2 to this Section, which take into account Keulegan-Carpenter number KC and the relative roughness of the external pipe surface.

Keulegan-Carpenter number KC is determined by the formula

$$KC = V_w \tau / D_a \quad (4.3.1-8)$$

where $\tau = 8,4$ s — wave period for the water area considered.

Diagrams to determine the resistance factors of undulatory motion of water particles depending on Keulegan-Carpenter number KC and the relative roughness of the surface of the pipeline according to [9] are specified in Figs. 1-1 and 1-2 of Appendix 2.

Vertical linear wave load $F_{w,v}$, in N/m, is determined by the formula

$$F_{w,v} = c_v \frac{\rho_w V_w^2}{2} D_a \quad (4.3.1-9)$$

where c_v = resistance factor of undulatory motion of water particles determined by the following formula [9]:

$$\begin{cases} c_v = 5,05 & \text{at } 0 \leq KC < 5,335 \\ c_v = 1,3 - 0,105 \frac{KC - 80}{KC^{0,5}} & \text{at } 5,335 \leq KC < 80 \\ c_v = -KC \cdot 0,001667 + 1,4333 & \text{at } KC \geq 80 \end{cases} \quad (4.3.1-10)$$

The calculation results of the wave effect on the subsea pipeline selected as an example are provided in Table 4.2.1-3.

Table 4.3.1-3

Loads on offshore pipeline due to wave effect

KP, No.	Depth, in m	V_w , in m/s	a_w , in m/s ²	KC	c_d	c_i	c_v , in N/m	$F_{w,s}$, in N/m	$F_{w,is}$, in N/m	$F_{w,hs}$, in N/m	$F_{w,v}$, in N/m
0	11,0	1,93	1,34	46,32	0,65	1,80	1,82	427,95	234,38	487,93	1198,25
1	10,0	2,01	1,39	48,24	0,62	1,80	1,78	442,73	243,13	505,09	1271,08

DETERMINATION OF VALUES OF WAVE PARTICLE VELOCITIES AND ACCELERATIONS IN BOTTOM LAYER

1. The components of wave particle velocity and acceleration in bottom layer: $V_{w,x}$, $V_{w,z}$, $a_{w,x}$, $a_{w,z}$ are determined by Tables 1 — 4 depending on the following:

- h — seawater depth in way of the pipeline section under consideration, in m;
- H — wave height with 1 % probability per year, in m;
- τ — wave period with 1 % probability per year, in s.

The intermediate values of the velocity and acceleration components are determined by linear interpolation.

2. The values of H and τ are determined on the basis of a hydrometeorological engineering survey lengthwise of the subsea pipeline route. The RS Reference Data on Wind and Wave Conditions may be used for specifying the wave height and period with 10^{-2} /year probability for those regions of sea water areas (pipeline route sections) wherein these values were determined.

The design values of velocities V_w and accelerations a_w are determined by the following formulae:

$$V_w = \sqrt{V_{w,x}^2 + V_{w,z}^2}; \tag{2-1}$$

$$a_w = \sqrt{a_{w,x}^2 + a_{w,z}^2}. \tag{2-2}$$

Table 1

Horizontal component of velocity $V_{w,x}$ in m/s

Seawater depth $h = 10$ m					
Wave period, τ , s	Wave height H , in m				
	1	2	3	4	5
5	0,24	0,48	0,72	0,96	1,11
7	0,37	0,74	1,10	1,45	1,75
9	0,43	0,88	1,32	1,74	2,11
11	0,47	0,98	1,48	1,95	2,35
13	0,51	1,06	1,60	2,10	2,52
15	0,53	1,13	1,70	2,22	2,65
Seawater depth $h = 20$ m					
Wave period, τ , s	Wave height H , in m				
	1	3	6	8	10
5	0,051	0,168	—	—	—
7	0,163	0,492	0,996	1,315	1,514
9	0,235	0,709	1,417	1,863	2,248
11	0,275	0,841	1,690	2,224	2,692
13	0,301	0,932	1,890	2,488	3,011
15	0,319	1,004	2,050	2,695	3,254
Seawater depth $h = 30$ m					
Wave period, τ , s	Wave height H , in m				
	1	3	6	10	15
5	0,010	0,037	—	—	—
7	0,075	0,229	0,479	0,834	—
9	0,145	0,437	0,881	1,471	2,065
11	0,191	0,575	1,156	1,916	2,744
13	0,219	0,665	1,343	2,230	3,205
15	0,237	0,727	1,481	2,470	3,551

Table 1 — continued

Seawater depth $h = 40$ m					
Wave period, τ , s	Wave height H , in m				
	1	5	10	15	20
5	0,002	0,018	—	—	—
7	0,034	0,182	0,418	—	—
9	0,091	0,462	0,951	1,436	—
11	0,138	0,694	1,393	2,073	2,629
13	0,169	0,852	1,708	2,533	3,246
15	0,189	0,962	1,939	2,877	3,697
Seawater depth $h = 50$ m					
Wave period, τ , s	Wave height H , in m				
	1	10	15	20	25
5	0,001	—	—	—	—
7	0,015	0,205	—	—	—
9	0,057	0,609	0,953	—	—
11	0,101	1,027	1,552	2,050	2,344
13	0,133	1,345	2,014	2,650	3,183
15	0,155	1,576	2,357	3,099	3,746
Seawater depth $h = 70$ m					
Wave period, τ , s	Wave height H , in m				
	5	10	20	25	30
7	0,017	0,049	—	—	—
9	0,111	0,243	—	—	—
11	0,272	0,557	1,177	1,476	—
13	0,427	0,860	1,744	2,177	2,565
15	0,546	1,096	2,196	2,730	3,226
Seawater depth $h = 100$ m					
Wave period, τ , s	Wave height H , in m				
	5	10	20	25	30
7	0,002	0,006	—	—	—
9	0,026	0,060	—	—	—
11	0,104	0,216	0,488	0,642	—
13	0,218	0,442	0,922	1,177	1,435
15	0,330	0,663	1,345	1,693	2,042
Seawater depth $h = 125$ m					
Wave period, τ , s	Wave height H , in m				
	5	10	20	25	30
7	—	0,001	—	—	—
9	0,008	0,018	—	—	—
11	0,046	0,097	0,230	0,312	—
13	0,123	0,250	0,533	0,691	0,858
15	0,216	0,436	0,893	1,133	1,379
Seawater depth $h = 150$ m					
Wave period, τ , s	Wave height H , in m				
	5	10	20	25	30
9	0,002	0,006	—	—	—
11	0,020	0,043	0,108	0,151	0,193
13	0,068	0,140	0,305	0,402	0,507
15	0,141	0,285	0,589	0,752	0,923

Table 2

Vertical component of velocity $V_{w,z}$ in m/s

Seawater depth $h = 10$ m					
Wave period, τ , s	Wave height H , in m				
	1	2	3	4	5
5	0,04	0,08	0,11	0,14	0,16
7	0,04	0,07	0,11	0,14	0,16
9	0,03	0,06	0,09	0,12	0,15
11	0,03	0,06	0,09	0,12	0,14
13	0,02	0,05	0,08	0,11	0,14
15	0,02	0,05	0,08	0,11	0,13
Seawater depth $h = 20$ m					
Wave period, τ , s	Wave height H , in m				
	1	3	6	8	10
5	0,008	0,026	—	—	—
7	0,014	0,042	0,081	0,101	0,111
9	0,014	0,041	0,079	0,100	0,117
11	0,012	0,037	0,072	0,093	0,110
13	0,011	0,033	0,066	0,087	0,105
15	0,010	0,030	0,062	0,083	0,101
Seawater depth $h = 30$ m					
Wave period, τ , s	Wave height H , in m				
	1	3	6	10	15
5	0,002	0,006	—	—	—
7	0,006	0,019	0,038	0,060	—
9	0,008	0,023	0,046	0,073	0,094
11	0,008	0,023	0,044	0,071	0,095
13	0,007	0,021	0,041	0,066	0,091
15	0,006	0,019	0,038	0,061	0,087
Seawater depth $h = 40$ m					
Wave period, τ , s	Wave height H , in m				
	1	5	10	15	20
5	—	0,003	—	—	—
7	0,003	0,014	0,030	—	—
9	0,005	0,023	0,046	0,065	—
11	0,005	0,025	0,049	0,069	0,083
13	0,005	0,024	0,047	0,067	0,082
15	0,005	0,022	0,044	0,063	0,079
Seawater depth $h = 50$ m					
Wave period, τ , s	Wave height H , in m				
	1	10	15	20	25
7	0,001	0,015	—	—	—
9	0,003	0,029	0,043	—	—
11	0,004	0,035	0,051	0,064	0,069
13	0,004	0,035	0,051	0,065	0,075
15	0,003	0,034	0,049	0,062	0,073

Table 2 — continued

Seawater depth $h = 70$ m					
Wave period, τ , s	Wave height H , in m				
	5	10	20	25	30
7	0,001	0,003	—	—	—
9	0,005	0,011	—	—	—
11	0,009	0,018	0,036	0,043	—
13	0,011	0,021	0,041	0,050	0,056
15	0,011	0,022	0,042	0,050	0,058
Seawater depth $h = 100$ m					
Wave period, τ , s	Wave height H , in m				
	5	10	20	25	30
9	0,001	0,003	—	—	—
11	0,003	0,007	0,015	0,019	—
13	0,005	0,011	0,021	0,026	0,031
15	0,006	0,012	0,024	0,030	0,035
Seawater depth $h = 125$ m					
Wave period, τ , s	Wave height H , in m				
	5	10	20	25	30
9	—	0,001	—	—	—
11	0,002	0,003	0,007	0,009	—
13	0,003	0,006	0,012	0,015	0,018
15	0,004	0,008	0,016	0,020	0,024
Seawater depth $h = 150$ m					
Wave period, τ , s	Wave height H , in m				
	5	10	20	25	30
11	0,001	0,001	0,003	0,004	—
13	0,002	0,003	0,007	0,009	0,011
15	0,003	0,005	0,010	0,013	0,016

Table 3

Vertical component of acceleration $a_{w,x}$, in m/s^2

Seawater depth $h = 10$ m					
Wave period, τ , s	Wave height H , in m				
	1	2	3	4	5
5	0,30	0,60	0,90	1,17	1,33
7	0,32	0,64	0,94	1,22	1,45
9	0,29	0,58	0,86	1,13	1,37
11	0,26	0,52	0,80	1,07	1,32
13	0,23	0,49	0,77	1,04	1,29
15	0,21	0,47	0,75	1,02	1,27
Seawater depth $h = 20$ m					
Wave period, τ , s	Wave height H , in m				
	1	3	6	8	10
5	0,064	0,211	—	—	—
7	0,146	0,439	0,881	1,149	1,300
9	0,163	0,485	0,950	1,230	1,460
11	0,155	0,463	0,905	1,178	1,416
13	0,142	0,427	0,851	1,119	1,364
15	0,129	0,395	0,808	1,078	1,326

Table 3 — continued

Seawater depth $h = 30$ m					
Wave period, τ , s	Wave height H , in m				
	1	3	6	10	15
5	0,013	0,046	—	—	—
7	0,067	0,205	0,429	0,741	—
9	0,101	0,304	0,609	1,005	1,372
11	0,108	0,324	0,643	1,046	1,459
13	0,105	0,314	0,621	1,009	1,426
15	0,098	0,294	0,585	0,961	1,381
Seawater depth $h = 40$ m					
Wave period, τ , s	Wave height H , in m				
	1	5	10	15	20
5	0,003	0,023	—	—	—
7	0,030	0,163	0,374	—	—
9	0,064	0,322	0,660	0,985	—
11	0,079	0,393	0,782	1,145	1,421
13	0,081	0,404	0,797	1,159	1,456
15	0,079	0,391	0,770	1,123	1,426
Seawater depth $h = 50$ m					
Wave period, τ , s	Wave height H , in m				
	1	10	15	20	25
5	0,001	—	—	—	—
7	0,013	0,184	—	—	—
9	0,040	0,424	0,661	—	—
11	0,058	0,582	0,874	1,141	1,282
13	0,064	0,639	0,945	1,226	1,447
15	0,065	0,640	0,942	1,220	1,453
Seawater depth $h = 70$ m					
Wave period, τ , s	Wave height H , in m				
	5	10	20	25	30
7	0,015	0,044	—	—	—
9	0,078	0,170	—	—	—
11	0,155	0,318	0,668	0,833	—
13	0,206	0,414	0,832	1,031	1,203
15	0,228	0,454	0,898	1,105	1,292
Seawater depth $h = 100$ m					
Wave period, τ , s	Wave height H , in m				
	5	10	20	25	30
7	0,001	0,005	—	—	—
9	0,018	0,042	—	—	—
11	0,059	0,123	0,279	0,365	—
13	0,105	0,213	0,444	0,566	0,688
15	0,138	0,277	0,560	0,703	0,845
Seawater depth $h = 125$ m					
Wave period, τ , s	Wave height H , in m				
	5	10	20	25	30
7	—	0,001	—	—	—
9	0,005	0,013	—	—	—
11	0,026	0,055	0,131	0,178	—
13	0,059	0,121	0,257	0,334	0,413
15	0,091	0,183	0,373	0,473	0,575

Table 3 — continued

Seawater depth $h = 150$ m					
Wave period, τ , s	Wave height H , in m				
	5	10	20	25	30
9	0,002	0,004	—	—	—
11	0,011	0,025	0,062	0,086	—
13	0,033	0,068	0,148	0,194	0,244
15	0,059	0,119	0,246	0,315	0,386

Table 4

Vertical component of acceleration $a_{w,z}$, in m/s^2

Seawater depth $h = 10$ m					
Wave period, τ , s	Wave height H , in m				
	1	2	3	4	5
5	0,05	0,10	0,15	0,18	0,21
7	0,03	0,07	0,11	0,14	0,17
9	0,03	0,05	0,09	0,12	0,15
11	0,02	0,05	0,08	0,11	0,14
13	0,02	0,04	0,07	0,10	0,13
15	0,01	0,04	0,07	0,10	0,13
Seawater depth $h = 20$ m					
Wave period, τ , s	Wave height H , in m				
	1	3	6	8	10
5	0,010	0,033	—	—	—
7	0,013	0,039	0,074	0,089	0,103
9	0,010	0,029	0,057	0,075	0,091
11	0,007	0,023	0,048	0,064	0,080
13	0,006	0,019	0,042	0,058	0,074
15	0,005	0,017	0,039	0,054	0,069
Seawater depth $h = 30$ m					
Wave period, τ , s	Wave height H , in m				
	1	3	6	10	15
5	0,002	0,007	—	—	—
7	0,006	0,017	0,035	0,055	—
9	0,005	0,016	0,033	0,050	0,068
11	0,004	0,013	0,026	0,042	0,061
13	0,003	0,011	0,022	0,037	0,055
15	0,003	0,009	0,019	0,033	0,050
Seawater depth $h = 40$ m					
Wave period, τ , s	Wave height H , in m				
	1	5	10	15	20
5	—	0,003	—	—	—
7	0,002	0,013	0,028	—	—
9	0,003	0,017	0,033	0,046	—
11	0,003	0,015	0,028	0,040	0,050
13	0,002	0,012	0,024	0,035	0,045
15	0,002	0,010	0,020	0,031	0,041

Table 4 — continued

Seawater depth $h = 50$ m					
Wave period, τ , s	Wave height H , in m				
	1	10	15	20	25
7	0,001	0,013	—	—	—
9	0,002	0,021	0,031	—	—
11	0,002	0,020	0,030	0,036	0,041
13	0,002	0,017	0,025	0,032	0,039
15	0,001	0,015	0,022	0,029	0,035
Seawater depth $h = 70$ m					
Wave period, τ , s	Wave height H , in m				
	5	10	20	25	30
7	0,001	0,003	—	—	—
9	0,004	0,008	—	—	—
11	0,005	0,011	0,021	0,025	—
13	0,005	0,011	0,020	0,024	0,027
15	0,005	0,009	0,017	0,021	0,025
Seawater depth $h = 100$ m					
Wave period, τ , s	Wave height H , in m				
	5	10	20	25	30
9	0,001	0,002	—	—	—
11	0,002	0,004	0,009	0,011	—
13	0,003	0,005	0,011	0,013	0,015
15	0,003	0,005	0,010	0,013	0,015
Seawater depth $h = 125$ m					
Wave period, τ , s	Wave height H , in m				
	5	10	20	25	30
9	—	0,001	—	—	—
11	0,001	0,002	0,004	0,005	—
13	0,001	0,003	0,006	0,008	0,009
15	0,002	0,003	0,007	0,009	0,010
Seawater depth $h = 150$ m					
Wave period, τ , s	Wave height H , in m				
	5	10	20	25	30
11	—	0,001	0,002	0,003	—
13	0,001	0,002	0,003	0,004	0,005
15	0,001	0,002	0,004	0,006	0,007

DETERMINATION OF FACTORS TO CALCULATE WAVE LOADS¹

1. Drag and inertia factors c_d and c_i for wave particle flow perpendicular to pipeline sections shall mainly depend on the Keulegan-Carpenter number KC , the relative roughness k of the pipeline surface, and shall be calculated according to the diagrams in Figs. 1-1 and 1-2.

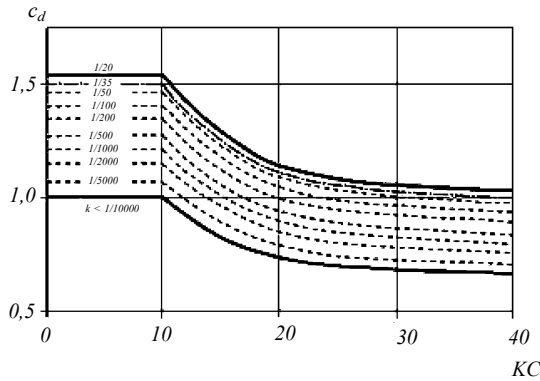

Fig. 1-1 Factor c_d in relation to the Keulegan-Carpenter number, KC , and relative roughness, k , of the pipeline surface

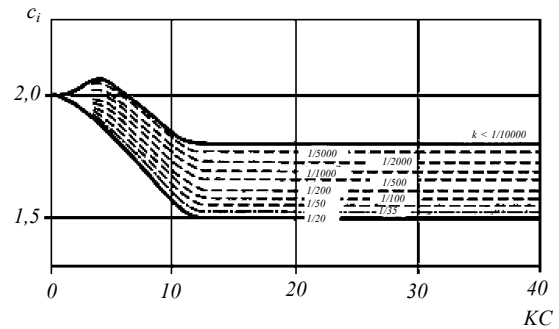

Fig. 1-2 Factor c_i in relation to the Keulegan-Carpenter number, KC , and relative roughness, k , of the pipeline surface

The Keulegan-Carpenter number KC shall be determined by the formula:

$$KC = V_w \tau / D_a \quad (1)$$

where V_w = water particle velocity, in m/s (refer to 2.6.2, Part I "Subsea Pipelines" of the SP Rules);
 τ = wave period, in s (refer Appendix 5);
 D_a = refer to Formulae (2.5.1-1), (2.5.1-2) and (2.5.1-3), Part I "Subsea Pipelines" of the SP Rules, in m.

2. For pipelines lying at distance d , in m, (refer to Fig. 2) above the seabed, c_d and c_i factors are determined by the formulae:

$$c_d(d/D_a) = c_d + (c_{db} - c_d) e^{-2,5d/D_a}, \quad (2-1)$$

$$c_i(d/D_a) = c_i + (c_{ib} - c_i) e^{-2,5d/D_a} \quad (2-2)$$

$$\text{where } \begin{cases} c_{db} = 1,8 + 0,136KC & \text{at } 0 \leq KC \leq 5; \\ c_{db} = 1,25 + 2,14 \cdot 10^{-9}(KC - 160)^4 & \text{at } KC > 5 \end{cases} \quad (2-3)$$

$$\begin{cases} c_{ib} = 3,3 - 0,0375KC & \text{at } 0 \leq KC \leq 8; \\ c_{ib} = 1,742KC^{-0,267} & \text{at } KC > 8. \end{cases} \quad (2-4)$$

3. For partially buried pipelines the influence of the burial depth Δ (refer to Fig. 2) on the c_d and c_i factors shall be determined in accordance with Fig. 3.

¹Appendix is prepared according to the regulations of a recognized classification society and is a recommendation only.

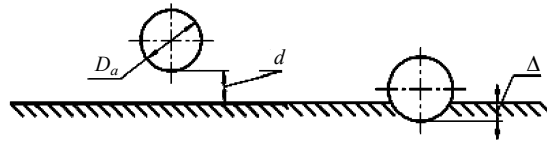

Fig. 2 Diagram of a pipeline lying at distance near the seabed

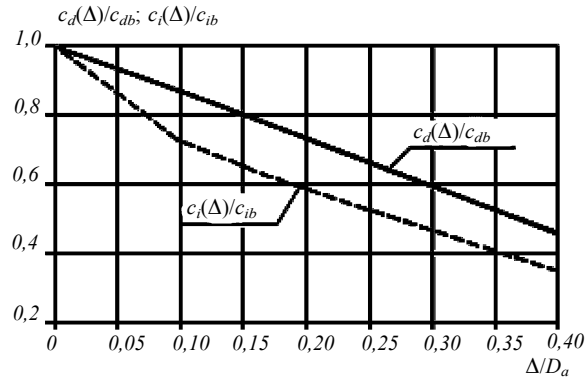

Fig. 3 c_d and c_i factor ratio in relation to the relative pipeline burial Δ/D_a

4. For pipelines located in open trenches (refer to Fig. 4), the influence of trench depth δ_t , in m, and slope S_t on c_d and c_i factors is determined in accordance with Table 4.

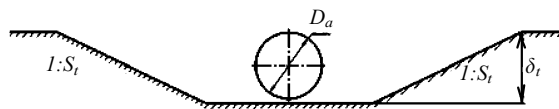

Fig. 4 Diagram of a pipeline in open trenches

Table 4

Influence of open trenches on c_d and c_i factors

δ_t/D_a	0,5	1,0	1,0
S_t	5	5	3
$c_d(\delta_t, S_t)/c_{db}$	0,8	0,7	0,6
$c_i(\delta_t, S_t)/c_{ib}$	0,9	0,8	0,75

5. Factor c_v , shall be determined from the formulae:

$$\begin{cases} c_v = 5,05 & \text{at } 0 \leq KC \leq 5,335 \\ c_v = 1,3 - 0,105 \frac{(KC - 80)}{KC^{0,5}} & \text{at } 5,335 < KC \leq 80 \\ c_v = -KC \cdot 0,001667 + 1,4333 & \text{at } KC > 80 \end{cases} \quad (5)$$

6. The influence of a small distance d , m, between pipeline section and the sea bottom on the near bottom lift factor c_v shall be determined by the formula:

$$c_v(d/D_a) = c_v e^{-2,5d/D_a} \tag{6}$$

7. For partially buried pipelines the influence of the burial depth Δ , in m, on c_v factor shall be determined from Fig. 7.

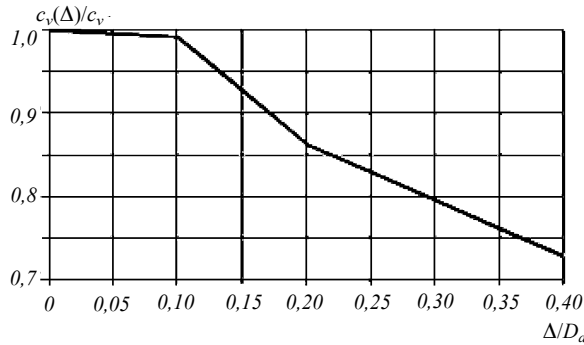

Fig. 7 $c_v(\Delta)/c_v$ factor in relation to the relative pipeline burial Δ/D_a

8. For pipelines in open trenches, the influence of trench depth δ_t , in m, and slope S_t on c_v factor shall be determined in accordance with Table 8.

Table 8

Influence of open trenches on c_v value

δ_t/D_a	0,5	1,0	1,0
S_t	5	5	3
$c_v(\delta_t, S_t)/c_v$	0,85	0,7	0,65

9. In case of combined linear current and wave loads the c_{db} , c_{ib} , c_v factors are corrected depending on the design current velocity and design wave particle velocity — ratio β (refer 2.5 and 2.6, Part I "Subsea Pipelines" of the SP Rules), which is equal to $\beta = V_c/V_w$, in accordance with Fig. 9-1 to 9-3.

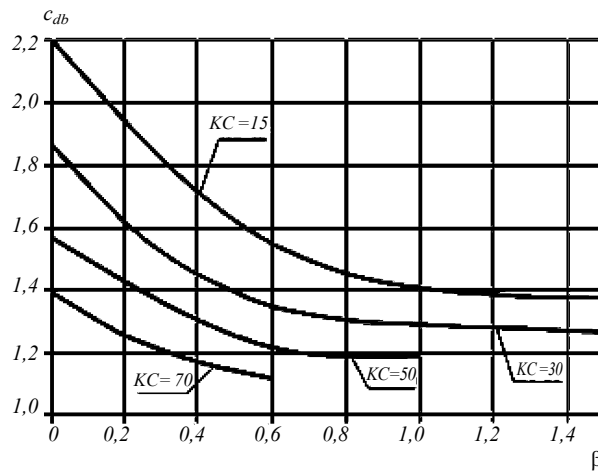

Fig. 9-1 Factor c_{db} in relation to factor β

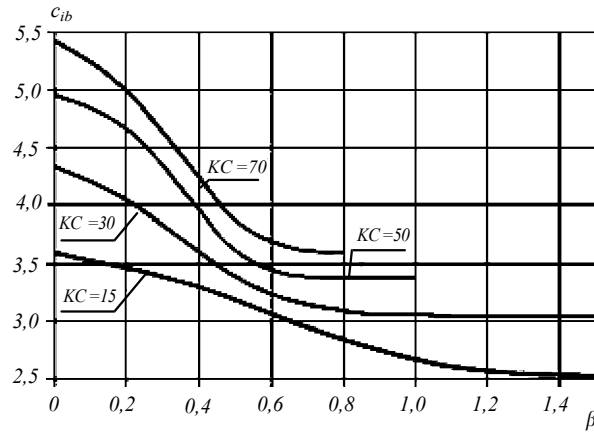

Fig. 9-2 Factor c_{ib} in relation to factor β

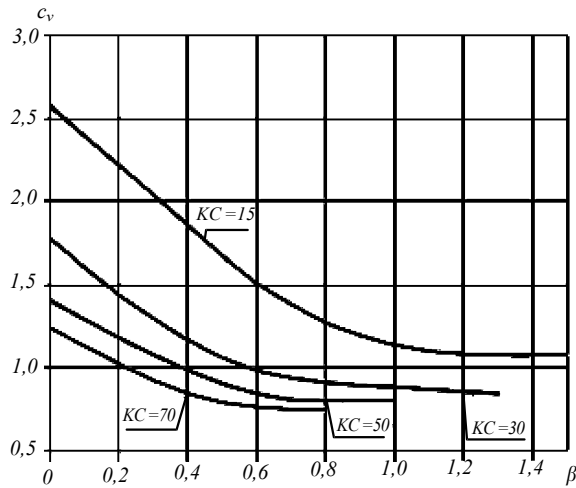

Fig. 9-3 Factor c_v in relation to factor β

The resultant $c_{db}(\beta)$ and $c_{ib}(\beta)$ values will be true for subsea pipelines lying at distance d , in m, above the seabed, for partially buried pipelines and pipelines in open trenches.

REFERENCES

1. Borodavkin P.P., Berezin V.L., Shadrin O.B. Submarine Pipelines. Moscow, Nedra, 2004.
2. Borodavkin P.P. Offshore Oil and Gas Facilities. Parts 1 and 2. Moscow, Nedra, 2006.
3. Goryainov Yu.A., Vasilyev G.G., Fedorov A.S. et al. Offshore Pipelines. Moscow, Nedra, 2001.
4. GOST R 54382-2011 Oil and Gas Industry. Submarine Pipeline Systems. General Requirements.
5. SP 11-102-97 Engineering and Environmental Survey for Construction.
6. SP 36.13330.2012 Trunk Pipelines. Revised edition of SNIIP 2.05.06-85*.
7. SP 86.13330.2012 Trunk Pipelines. Revised edition of SNIIP III-42-80*.
8. Papusha A.N. Designing of Offshore Submarine Pipeline: Calculation for Strength, Bending and Stability of Offshore Pipeline in Mathematica — Moscow: Gubkin Russian State University of Oil and Gas, 2006.
9. Rules and Guidelines Industrial Services. IV — Part 8. Pipelines. Chapter 1. Rules for Subsea Pipelines and Risers. Germanischer Lloyd Offshore and Industrial Services GmbH, 2004.

5 STRENGTH OF SUBSEA PIPELINES

The strength analysis of subsea pipelines shall be based on classical or semi-empirical procedures and numerical methods that take into consideration the combination of actual design loads, boundary conditions and resistance parameters of pipes deviating from regular round shape.

5.1 DETERMINATION OF THE STEEL PIPELINE WALL THICKNESS

Selection of the steel subsea pipeline wall thickness, which is one of the most important design stages, shall be based on the necessity to ensure the pipeline strength (stability) and required safety level.

The calculations shall be made for the most unfavorable combination of possible loads.

The wall thickness of the steel pipeline shall be determined based on the following conditions:

local strength of the pipeline characterized by the maximum values of hoop stresses;
adequate local buckling of the pipeline.

The wall thickness of the steel pipeline based on local strength shall be determined by the formula (numerical values of the parameters correspond to the sample calculation specified above):

$$t_c = (\gamma p_0 D_a) / (2\sigma\varphi) + c_1 + c_2 = (8,0 \cdot 350) / (2 \cdot 209,51 \cdot 0,9) + 1,0 + 0,75 = 9,17 \text{ mm} \quad (5.1-1)$$

where

p_0 = design pressure in pipeline, in MPa;

D_a = pipeline outside diameter, in mm;

σ = permissible stress of pipe material, in MPa,

$\gamma = 1,1$ — significance factor of load components due to internal pressure for gas pipelines according to Table 2.1.1, Part I "Subsea Pipelines" of the SP Rules.

Permissible stress σ shall be taken by the least of the values for the selected pipe material specified below (steel X52). In such case, pipeline class G3 is assigned for seismically active regions and ice-resistant standpipes, which determines a higher level of the strength factors in terms of yield stress and tensile strength, which are assigned according to Table 3.2.5, Part I "Subsea Pipelines" of the SP Rules.

$$\sigma = \min(R_e / n_e; R_m / n_m) = \min(358 / 1,22; 55 / 1,91) = \min(209,51; 28,27) = 209,51 \text{ MPa} \quad (5.1-2)$$

where

$R_e = 358$ — minimum yield strength of the pipe metal, in MPa;

$R_m = 455$ — minimum tensile strength of the pipe metal, in MPa;

$n_e = 1,22$ — strength factor in terms of yield stress;

$n_m = 1,91$ strength factor in terms of tensile stress;

$\varphi = 0,9$ — strength factor determined depending on the pipe manufacturing method in accordance with 3.2.4, Part I "Subsea Pipelines" of the SP Rules;

$c_1 = 1,0$ — corrosion allowance, in mm;

$c_2 = 0,75$ — allowance to compensate for negative manufacturing tolerance for seamless steel pipes of the diameter specified, in mm.

In accordance with the technical specifications for the supply of pipes or the relevant applicable standard (e.g. GOST 8732-78 "Seamless hot-deformed steel pipes"), the nominal wall thickness of the offshore pipeline t_n is 12,0 mm. Given this wall thickness, a weight of 1 m of the pipe is 100,32 kg.

Total maximum stresses in the pipeline σ_{\max} , in MPa, caused by the internal and external pressures, longitudinal forces (e.g. due to thermal expansion and/or elastic bending of the pipeline sections), as well as the external loads shall not exceed the permissible stresses:

$$\sigma_{\max} = \sqrt{\sigma_x^2 + \sigma_{hp}^2 - \sigma_x \sigma_{hp} + 3\tau^2} \leq k_\sigma R_e \quad (5.1-3)$$

where

σ_{hp} = total hoop stresses, in MPa;

$$\sigma_{hp} = (p_0 D_{int})/t_n = (8 \times 326)/12 = 217,3 \text{ MPa} \quad (5.1-4)$$

where p_0 = design pressure in the pipeline, in MPa, determined by Formula (4.2-1);
 D_{int} = 326 mm — internal diameter of the pipe;
 t_n = 12,0 mm — nominal pipe wall thickness;
 σ_x = total longitudinal stresses, in MPa;

$$\sigma_x = \mu \sigma_{hp} - \alpha E \Delta t = 0,3 \cdot 217,3 - 11,6 \cdot 10^{-6} \cdot 204570 \cdot 50 = -53,46 \text{ MPa} \quad (5.1-5)$$

where μ = 0,3 — coefficient of lateral deformation of steel (Poisson's ratio);
 α = $11,6 \cdot 10^{-6}$ — lineal expansion coefficient of the pipe metal, in deg^{-1} ;
 E = 204570 MPa — modulus of elasticity (Young's modulus), in MPa;
 Δt = 50 °C — design temperature difference during gas transportation considering the minimum ambient temperature (sea water at the seabed surface);
 σ_{hp} = total hoop stresses, in MPa, determined by Formula (5.1-4);
 τ = tangential (shear) stresses, in MPa, due to shear forces from current and waves determined by the following formula:

$$\tau = M_t / W_p + Q / F \quad (5.1-6)$$

where M_t = $Q(D_a/2 + \delta_s/6)$ — torsional moment, in N·m, due to eccentric effect of current on the pipeline, which results from its partial subsidence into seabed soil to value of δ_s ;
 δ_s = 0,105 m — seabed soil subsidence value to KP No. 1 (refer to Table 3.3.6);
 W_p = $0,5n(D_a - t_n)2t_n$ — torsional section modulus of pipe cross-section, in m^3 ;
 Q = total design shear forces from current and waves, in N, acting at KP No. 1 per unit length of a pipeline (refer to Table 4.2.1-2 and 4.2.1-3) equal to Fg used when verifying pipeline stability on seabed (refer to Table 6.1);
 Q = 16,341 + 505,09 = 521,43 N;
 F = $\pi(D_a - t_n)t_n$ — pipe cross section area, in m^2 .

Tangential (shear) stresses considering the values of M_t , W_p and F are equal to:

$$\tau = \frac{Q(2D_a + \delta_s/3 - t_n)}{(\pi(D_a - t_n)^2 t_n)} 10^{-6} = \frac{521,43(2 \cdot 0,35 + 0,105/3 - 0,012)}{(3,14(0,35 - 0,012)^2 \cdot 0,012)} 10^{-6} = 0,087577 \text{ MPa};$$

k_σ = 0,727 — strength factor in terms of total stresses determined according to Table 3.2.6, Part I "Subsea Pipelines" of the SP Rules;
 R_e = minimum yield stress of the pipe metal, in MPa, determined by Formula (5.1-2).

Thus, total maximum stresses in the pipeline in accordance with Formula (5.1-3), in MPa, do not exceed permissible stresses:

$$\sigma_{\max} = \sqrt{53,46^2 + 217,3^2 - 53,46 \cdot 217,3 + 3 \cdot 0,0876^2} \leq 0,727 \cdot 358; \quad (5.1-7)$$

$$\sigma_{\max} = 196,11 < 260,26.$$

Based on Formula (5.1-7) for the sample calculation under consideration, a conclusion can be made that the strength condition of the subsea gas pipeline with respect to the total stresses is satisfied.

5.2 APPLICATION OF SOFTWARE FOR PIPELINE STRENGTH TESTING

Being recently developed and widely used in the practice of designing, the software based on the numerical simulation modelling of the pipeline and the external conditions of its routing (e.g. SAGE Profile 3D developed by Fugro GeoConsulting, or OrcaFlex system developed by Orcina Ltd.) allows to determine the stress-strain state of the subsea pipeline in operation more accurately than by using engineering methods. Generally, such software shall be designed for two- and three-dimensional simulation modelling of the processes of laying, testing and operating the subsea pipelines based on a finite-element non-linear model of pipelines with rod-shaped thin-walled tubular finite elements.

The input parameters for such software shall be the following:

length of design finite element of pipeline;
seabed profile a 3D grid or 2D profile format;
soil properties along the pipeline route;

pipeline characteristics: outside diameter, wall thickness, strength class, presence/absence of external corrosion-protection, insulating and weight coatings and their characteristics (density, thickness, water-saturation);

temperature conditions of the pipeline and ambient temperature (dependence of temperature change may be both linear and non-linear);

density of transported product, internal pressure in the pipeline (dependence of pressure change may be both linear and non-linear).

The algorithm of such programs shall take into account the non-linear pipe bending and non-linear soil response: bearing capacity, axial and horizontal resistance to friction. The external loads on the pipeline shall include the pipe self-weight, lay tension during installation, concentrated loads (e.g. galvanic anodes), distributed loads (e.g. currents and wave effects), specified displacements (e.g. seabed profile), as well as the internal and external pressures and temperature distribution. The topography of the seabed shall be based on the results of engineering survey along the pipeline route in a 3D grid or 2D profile format.

The interaction of the pipeline with the marine soil shall be simulated for the cases of laying the pipeline without burial (this determines the subsidence of the pipeline in the soil) and with the burial in the seabed soil. When laying on top of the seabed soil, the parameters of free spans of the pipeline shall be determined at the laying, hydraulic testing and operation stages.

Separately, the issue shall be considered to provide the strength of the subsea pipeline when it is buried in the seabed soil with the use of various types of pipe-burying devices (movement the pipeline from the seabed soil surface to the trench of a certain design depth with excessive bending stresses being prevented).

The software used in the design process of subsea pipelines under the RS technical supervision shall be approved by the Register with issue of a Type Approval Certificate for Software (form 6.8.5).

REFERENCES

1. Borodavkin P.P., Berezin V.L., Shadrin O.B. *Subsea Pipelines*. Moscow, Nedra, 2004.
2. Borodavkin P.P. *Offshore Oil and Gas Facilities. Parts 1 and 2*. Moscow, Nedra, 2006.
3. Goryainov Yu.A., Vasilyev G.G., Fedorov A.S. et al. *Offshore Pipelines*. Moscow, Nedra, 2001.
4. Vasiliev G.G., Goryainov Yu.A., Bepalov A.P. *Construction of Offshore Pipelines*. — Moscow, Gubkin Russian State University of Oil and Gas, 2015.
5. GOST R 54382-2011 Oil and Gas Industry. *Submarine Pipeline Systems. General Requirements*.
6. SP 36.13330.2012 *Trunk Pipelines*. Revised edition of SNiP 2.05.06-85*.
7. SP 86.13330.2012 *Trunk Pipelines*. Revised edition of SNiP III-42-80*.
8. Papusha A.N. *Designing of Offshore Submarine Pipeline: Calculation for Strength, Bending and Stability of Offshore Pipeline in Mathematica* — Moscow: Gubkin Russian State University of Oil and Gas, 2006.

6 BALLASTING OF SUBSEA PIPELINES

6.1 BALLASTING OF PIPELINES NOT BURIED INTO SEABED SOIL

Ballasting of the subsea pipeline is required for ensuring positive buoyancy compensation and on bottom stability by creating resistance to current and wave induced horizontal and vertical forces, as well as for ensuring protection against impacts during transportation, installation and operation.

Weight coating for ballasting and mechanical protection of pipelines shall be approved by the Register and comply with the following requirements:

sufficient density and thickness to provide necessary negative buoyancy to the pipeline;

sufficient mechanical strength to withstand damage during pipe transportation, installation and operation;

sufficient durability, chemical and mechanical resistance to the sea water.

Calculation of the ballast required and spacing between the single ballast weights for the pipelines non-buried into the seabed soil shall be made based on the conditions for creating negative buoyancy to the pipeline, wave and current induced displacement resistance, as well as taking into account vertical forces occurring in curved sections of the pipeline.

The required weight of submerged ballast Q_b , in kN/m, is determined by the formula (numerical values of the parameters correspond to the sample calculation specified above):

$$Q_b \geq \frac{F_g}{f_{fr}} k_{st} + (F_v + q_u + q_z) k_e - Q_p \quad (6.1-1)$$

where $f_{fr} = 0,25$ — friction coefficient (refer to Formula (6.1.7), Part I "Subsea Pipelines" of the SP Rules);
 $k_e = 1,25$ — pipeline floating-up stability factor (refer to Formula (6.1.7), Part I "Subsea Pipelines" of the SP Rules);
 $k_{st} = 1,3$ — pipeline shear stability factor (refer to Formula (6.1.7), Part I "Subsea Pipelines" of the SP Rules);
 $q_u = 0$ — vertical force occurring during elastic bending of pipelines in vertical plane, in kN/m;
 $q_z = 0$ — vertical force occurring during lateral tensile pull in curved pipeline, in kN/m;
 F_g — total horizontal component of force action of waves and current determined in accordance with Section 4 of these Recommendations, in kN/m;

$$F_g = F_{c,h} + F_{w,h}; \quad (6.1-2)$$

F_v = total vertical component of wave- and current induced force determined in accordance with Section 4 of these Recommendations, in kN/m;

$$F_v = F_{c,v} + F_{w,v}; \quad (6.1-3)$$

Q_p = submerged pipe weight per unit length considering weight of corrosion protection and insulation (without weight of transported medium and wall thickness allowance for corrosion), kH/m;

$$Q_p = P - F_A = m \cdot g - \rho_w \cdot g \cdot V = 100,32 \cdot 9,8 - 1010 \cdot 9,8 \cdot 0,0962 = 0,31 \text{ kN/m} \quad (6.1-4)$$

where P = weight of 1 m of pipeline in the air at wall thickness of 12 mm;
 F_A = Archimedes force acting on 1 meter of pipeline.

Calculation results of the ballasting of the subsea pipeline are provided in Table 6.1.

Table 6.1

Ballasting calculation of non-buried subsea gas pipeline

KP, No.	$F_{c,h}$, in kN/m	$F_{w,h}$, in kN/m	F_g , in kN/m	$F_{c,v}$, in kN/m	$F_{w,v}$, in kN/m	F_v , in kN/m	Q_p , in kN/m	Q_b , in kN/m
0	0,0163	0,488	0,504	0,0327	1,198	1,231	0,31	2,421
1	0,0163	0,505	0,521	0,0327	1,271	1,304	0,31	2,552
2	0,0273		0,027	0,0546		0,055	0,31	-0,177
3	0,0273		0,027	0,0546		0,055	0,31	-0,177
4	0,0326		0,033	0,0653		0,065	0,31	-0,151
5	0,0327		0,033	0,0654		0,065	0,31	-0,151
6	0,0305		0,031	0,0610		0,061	0,31	-0,162
7	0,0305		0,031	0,0610		0,061	0,31	-0,162
8	0,0260		0,026	0,0519		0,052	0,31	-0,184
9	0,0260		0,026	0,0519		0,052	0,31	-0,184
10	0,0260		0,026	0,0519		0,052	0,31	-0,184
11	0,0260		0,026	0,0519		0,052	0,31	-0,184
12	0,0260		0,026	0,0519		0,052	0,31	-0,184
13	0,0260		0,026	0,0519		0,052	0,31	-0,184
14	0,0260		0,026	0,0519		0,052	0,31	-0,184
15	0,0327		0,033	0,0654		0,065	0,31	-0,151

Values of vertical forces q_u and q_s are determined by the procedure agreed with the Register taking into account parameters of subsea pipeline route section (length and camber of the pipeline elastic deflection if there are free spans along the pipeline route).

To determine vertical forces q_u and q_s (refer to Formula (6.1.7), Part I "Subsea Pipelines" of the SP Rules), which reduce the resultant of the vertical forces on subsea pipeline and, therefore, reduce the friction force that prevents subsea pipeline displacement due to the effects of waves and currents it is preferable to follow the relevant calculation recommendations [1 — 3].

When determine the above parameters, the following shall be taken unto account:

vertical forces occurring when subsea pipelines are laid in the route sections with concavity (saddle shaping), which parameters (length l and bend deflection f) are determined during engineering survey;

concavity parameter of the route section — radius R_1 determined by length l and bend deflection f shall not exceed the value specified in 8.2.1.6, Part I "Subsea Pipelines" of the SP Rules;

value of tensile force in the subsea pipeline that contributes to the occurrence of the vertical forces errored on the safe side may be taken equal to the tensile force when laying from the pipelayer;

when laying from the pipelayer at the tensile forces on the route section with concavity, the vertical forces are determined as sum $q_u + q_s$ provided that the subsea pipeline is considered as a beam with fixed ends.

In the specified example where there are no vertical forces, the calculation results show that the pipeline weight is not sufficient since it is subject to the effect of excessive buoyant forces in seawater (positive buoyancy).

The required outside radius of the concrete coating of the pipeline shall be determined as follows:

$$V = \frac{Q_b \times 100/g}{\rho_{con}} = \pi(R_{con}^2 - R_H^2)L. \tag{6.1-5}$$

Then, the outside radius of the concrete coating is determined by the following formula:

$$R_{con} = \sqrt{\frac{(Q_b \times 100/g)/\rho_{con}}{\pi L} + R_H^2} = \sqrt{\frac{(2,55 \times 100/9,8)/2700}{\pi \times 1} + 0,175^2} = 0,248 \text{ m}. \tag{6.1-6}$$

Then, a thickness of the concrete coating will be equal to:

$$t = R_{con} - R_H = 0,248 - 0,175 = 0,073 = 7,3 \cong 8 \text{ cm}.$$

In such case, the weight coating thickness is taken equal to 8,0 cm. For structural considerations, the subsea pipeline shall be provided with the 8-cm thick weight coating of reinforced concrete with a density of 2700 kg/m³ over its entire length.

Where a weight of the weight coating for 1 lin. m of the subsea pipeline is equal to 2,55 kN/m, the ballasting condition in accordance with Formula (6.1-1) will be fulfilled.

6.2 BALLASTING OF PIPELINES BURIED INTO SEABED SOIL

In the process of backfilling the subsea pipeline in the trench with soil or burying the pipeline previously laid on the seabed soil, the backfilling soil is mixed with water that provides the possibility of the soil turning into free-flowing state with a density much higher than the seawater density (up to 1600 kg/m³), which may also result in floating-up of the pipeline. In such case, the resistance of liquefied soil to shear is practically non-existent; on the other hand, the pipeline located in the trench is not affected by currents and waves. In this case, the stability condition of the subsea pipeline in the trench in terms of floating-up is determined as follows [4]:

$$\frac{4(Q_{pipe} + Q_{ins} + Q_p)}{\pi D_{out}^2} \geq k_e \rho_s \quad (6.2-1)$$

where Q_{pipe} = weight per unit length of a pipeline in the air, in kg/m;
 Q_{ins} = weight per unit length of insulation in the air, in kg/m;
 Q_p = weight of unit length of weight coating in the air, in kg/m;
 D_{out} = outside pipeline diameter taking into account insulation and weight coating, in m;
 ρ_s = density of liquefied soil (ratio of weight of solid soil particles, including a weight of water contained in it to their volume), in kg/m³, determined by the following formula:

$$\rho_s = \frac{\rho_{s.sk} \rho_w (1 + W)}{\rho_{s.sk} W + 1} \quad (6.2-2)$$

where $\rho_{s.sk}$ = soil skeleton density (ratio of weight of solid soil particles to their volume), in kg/m³;
 ρ_w = water density, in kg/m³;
 W = soil moisture content (ratio of water weight contained in soil pores to weight of solid soil particles), unit fraction.

REFERENCES

1. Borodavkin P.P., Berezin V.L., Shadrin O.B. Subsea Pipelines. Moscow, Nedra, 2004.
2. Borodavkin P.P. On the Issue of Stabilizing the Position of Underwater Pipelines for Transporting Oil and Gas. *Drilling and Oil*, 2008, No. 7 — 8.
3. Borodavkin P.P., Berezin V.L. Construction of Main Pipelines. Moscow, Nedra, 1977.
4. Borodavkin P.P. Offshore Oil and Gas Facilities. Parts 1 and 2. Moscow, Nedra, 2006.
5. Kapustin K.Ya., Kamyshev M.A. Construction of Offshore Pipelines. Moscow, Nedra, 1982.
6. Popova A.I., Vishnevskaya N.S. Concrete Weight Coated Pipes for Construction of Main Gas Pipeline Systems. Ukhta, UGTU, 2013.
7. Samoilo B.V., Kim B.I., Zonenko V.I., Klenin V.I. Construction Of Underwater Pipelines. Moscow, Nedra, 1995.
8. ISO 21809-5:2017 Petroleum and Natural Gas Industries — External Coatings for Buried or Submerged Pipelines Used in Pipeline Transportation Systems — Part 5: External Concrete Coatings.
9. STO Gazprom 2-2.2-334-2009 Repair and Construction of Main Gas Pipelines in Waterlogged and Boggy Areas, on Underwater Crossings with Application of Coated Pipes.
10. Zabela K.A. Elimination of Underwater Oil Pipeline Failures. Moscow, Nedra, 1986.
11. Melikov S.V., Lupasko K.N. Development of International Regulatory Framework for Design and Construction of Subsea Pipelines with Concrete Coating. *Pipeline Transport*, 2015, No. 1(47).
12. Filatov A.A., Topilin A.V., Veliyulin I.I. et al. Procedure of Calculation for Strength and Stability of Subsea Transitions of Concrete Pipes in Their Construction and Repair. *Special Issue Of Gas Industry Magazine*, 2015.
13. Popova A. Pipes for Offshore Pipeline Systems. LAP Lambert Academic Publishing, 2014.

7 LAYING OF SUBSEA PIPELINES

7.1 GENERAL

The main method of subsea pipeline construction in sea water areas is pipeline laying with the use of special pipe-laying vessels/barges (PLV), that allow constructing pipelines that comply with the required operating parameters of product transportation at significant depths in waves and with sufficient operation performance.

Approximately 70 % of PLVs use the method of pipeline tie-in on a horizontal firing line with further laying of this pipeline on the seabed over a stinger under tension. In this case, the pipeline section from the stinger to the point of contact with the seabed soil takes form of the *S*-curve. Such laying method is *S*-method of subsea pipeline laying [1] — refer to Fig. 7.1-1. In some cases, when the stinger length is insufficient (or when the use of sufficiently long stinger is impossible in shallow waters), additional buoyancy devices may be used to support the pipeline to be laid.

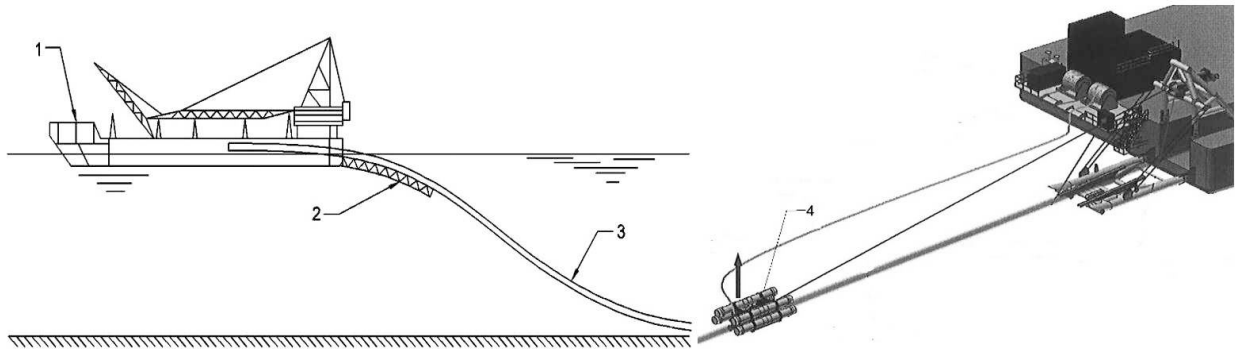

Fig. 7.1-1 *S*-method of subsea pipeline laying:
 1 — pipe-laying vessel/barge, 2 — stinger, 3 — pipeline, 4 — buoyancy device

The *S*-method has limitations for sea depth that depend on diameter and wall thickness of subsea pipelines. Generally, such method is applied for laying pipelines with diameters of up to 1220 mm at depths of up to 300 — 350 m and with diameters of up to 800 mm at depths of up to 700 m at a laying rate of 3 — 5 km/day [1].

To lay pipelines at depths exceeding the values specified above, *J*-method is applied with bending of the pipeline from the PLV to the point of contact with the seabed soil along the *J*-curve — refer to Fig. 7.1-2. Pipeline tie-in is performed on a vertical (or near-vertical) ramp, to which prefabricated pipe lengths are welded in pairs.

The main difference of *J*-method compared to *S*-method of laying is the absence of stinger and vertical position of the upper pipeline end in the process of laying at deep waters, that eliminates bending stresses in the upper end of the pipeline (refer to Fig. 7.1-3, *a*). Thus, two significant opposite bending moments are acting when applying *S*-method: the pipeline bends over the stinger on its departure (overbend) and sags near the point of contact with the seabed (buckling) having a point on its submerged length where curvature of the pipeline alternates its sign and the bending moment is equal to zero (refer to Fig. 7.1-3, *b*).

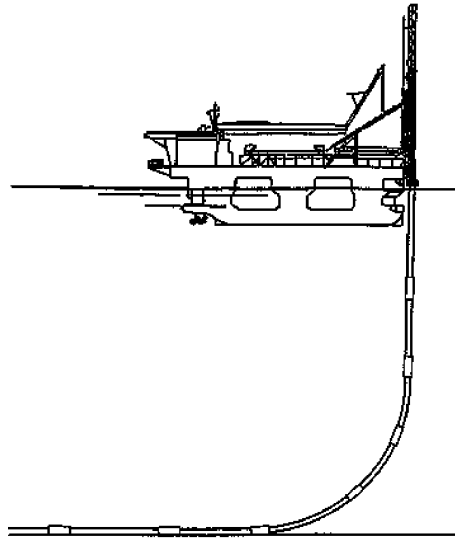

Fig. 7.1-2 *J*-method of subsea pipeline laying [1]

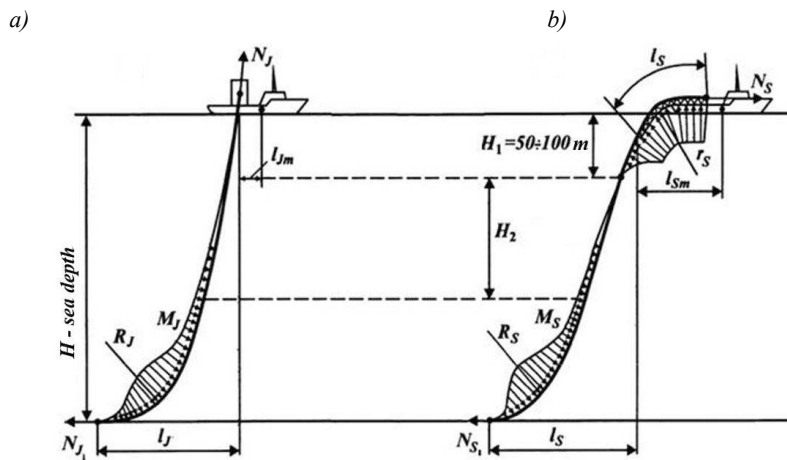

Fig. 7.1-3 Bending moment diagrams when laying pipelines by different methods [1]:
a — *J*-method; *b* — *S*-method

According to the analysis of characteristics of PLVs, that are currently used for *S*-method of laying in relatively shallow waters specific for Russian offshore oil-and-gas fields [1], non-propelled PLVs (barges) are quite effective. Non-propelled barges are positioned and moved in the process of pipeline laying using an anchor positioning system and repositioning of the anchors (refer to Fig. 7.1-4).

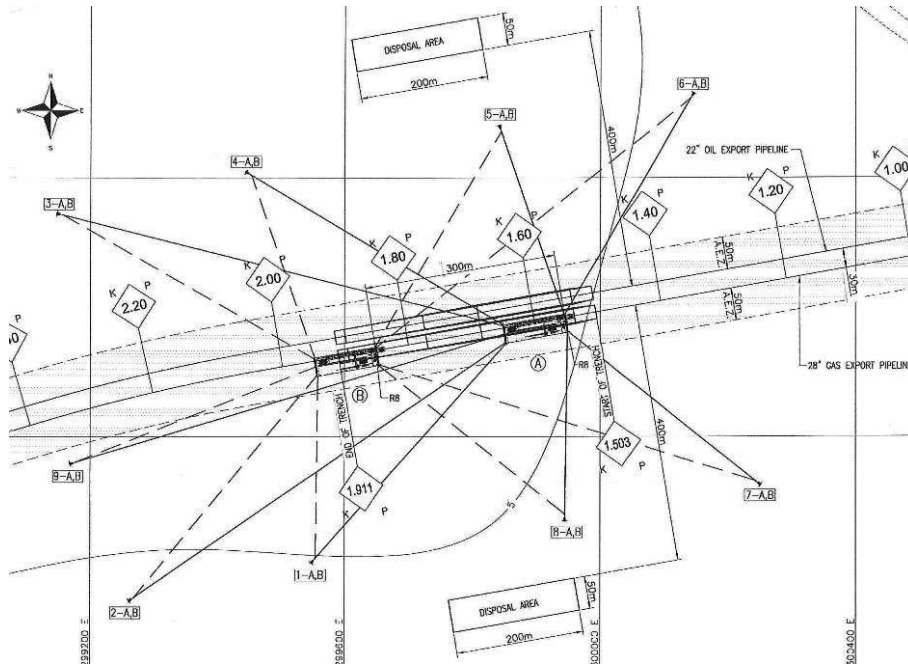

Fig. 7.1-4 Movement of a pipe-laying barge along the pipeline route using an anchor positioning system

Other methods of subsea pipeline laying are specified in 8.5, Part I "Subsea Pipelines" of the SP Rules and may be applied depending on particular characteristics of water areas, pipeline routes, production facilities of a contractor, etc.

7.2 STATIC STRENGTH CALCULATION OF THE PIPELINE TO BE LAID

This Chapter specifies an example of static calculation of a subsea pipeline laid from the SULEYMAN VEZIROV PLV (Reg. No. 743746, flag/owner — Azerbaijan), carried out on based on the calculation method specified in [2]. A concrete coated pipeline with parameters defined in sample calculations provided in the relevant Sections of these Recommendations: $\varnothing 350 \times 12$ mm, steel grade X52, concrete coating thickness — 80 mm.

Main particulars of the SULEYMAN VEZIROV PLV are as follows: $L \times B \times D \times d = 107 \times 24 \times 7,0 \times 3,48$ m. Stinger dimensions are as follows: length $l_s = 35,0$ m, curvature radius r_s is adjustable between 283 and 396 m.

The subsea pipeline is laid by *S*-method, some of the geometrical parameters are specified in Fig. 7.2-1.

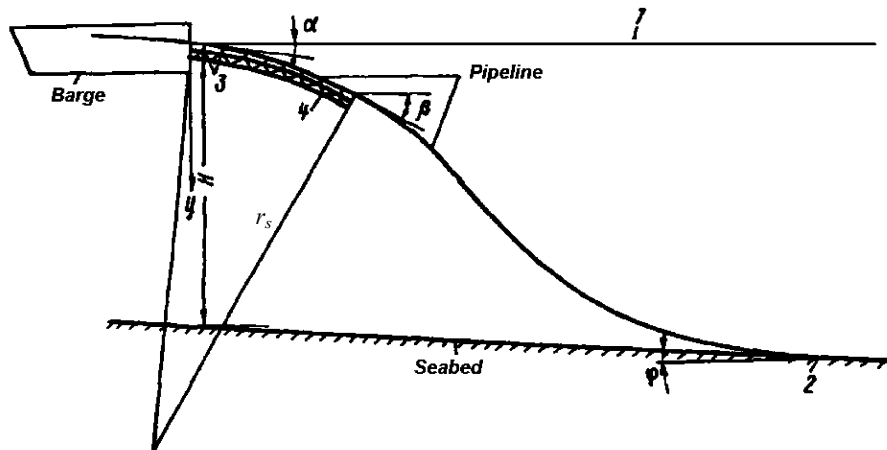

Fig. 7.2-1 Geometrical parameters of pipeline laying by *S*-method:

- 1 — water surface; 2 — point of contact with the seabed; 3 — roller supports;
 4 — stinger; $\alpha = 14^\circ = 0,244$ rad. — angle of the stern part of the firing line (initial stinger angle);
 β — pipeline departure angle from the stinger; φ — seabed slope angle; r_s — stinger radius

The pipeline length adjoining the stinger is curved with a stinger curvature radius r_s , while the stinger is considered as a rigid structure fitted with roller supports. Mathematically, the elastic bending of the pipeline is modeled as a continuous tubular beam. Fixed points of this beam are defined as a hinge-fixed support in the point of contact with the seabed and as movable hinges at roller supports of the stinger.

Loads acting on a pipeline bending over a stinger with a length of l_s are as follows:

self-weight of a pipeline (defined as a uniformly distributed load m taking into account weight of the concrete coating);

water pressure on pipeline walls (buoyancy force);

pipe tension N produced by the PLV tensioners.

Only the metal pipe is considered for the strength calculation. The concrete ballast coating is only considered as an additional weight load. However, the concrete coating itself shall be verified for maximum tensile strain based on the limitation condition for the width of lateral cracks in the tensile area of the concrete coating, e.g. based on [4] and [5]. Besides, in case the concrete coating does not cover the entire length of a pipe, but only its middle part, excluding 400 — 500 mm at each pipe end, it results in concentration of bending stresses in the zone of welded joints. To eliminate these effects, in some cases, with significant thickness and weight of the concrete coating, it is recommended to provide coating with ring slots [6].

According to the conditions of maximum allowable elastic bending of the pipeline taking into account its tension, the stinger curvature radius r_s shall be verified. The value of the radius shall exceed the minimum value of r_{min} , determined by the following formula:

$$r_s \geq \frac{EJ}{W([\sigma] - N/F)} = r_{min} \quad (7.2-1)$$

where J = moment of inertia of the metal pipe, in m^4 ;
 E = 204570 MPa — modulus of steel elasticity (Young's modulus);
 W = section modulus of the metal pipe, in m^3 ;
 $[\sigma]$ = 260 MPa — permissible stress (refer to Section 5 of these Recommendations)
 N = 45t = 0,441 MN — pipeline tension force on the PLV;
 F = cross-section area of the metal pipe, in m^2 .

$$J = \frac{\pi}{64} (D_a^4 - D_{int}^4) = \frac{\pi}{64} (0,35^4 - 0,326^4) = 0,000181 \text{ m}^4 \quad (7.2-2)$$

where $D_a = 0,35$ m and $D_{int} = 0,326$ m — outer and internal diameters of the metal pipe accordingly;

$$F = \frac{\pi}{4} (D_a^2 - D_{int}^2) = \frac{\pi}{4} (0,35^2 - 0,326^2) = 0,0127 \text{ m}^2; \quad (7.2-3)$$

$$W = \frac{\pi}{32D_a} (D_a^4 - D_{int}^4) = \frac{\pi}{32 \cdot 0,35} (0,35^4 - 0,326^4) = 0,00104 \text{ m}^3. \quad (7.2-4)$$

According to Formula (7.2-1), the value of curvature radius r_s is equal to:

$$r_s \geq \frac{(204570 \cdot 0,000181)}{0,00104(260 - (0,441/0,0127))} = 158 \text{ m}. \quad (7.2-5)$$

Thus, the stinger radius r_s may be taken equal to its minimum value for the specified PLV, i.e. 283 m.

Support reactions on the stinger are determined by the condition that the bending moment M_s , in kNm, in any section of the pipeline on the stinger is determined by its radius and rigidity of the pipeline:

$$M_s = EJ/r_s = (204570 \cdot 0,000181)/283 = 0,131 \text{ MH}_M = 131 \text{ kNm}. \quad (7.2-6)$$

Maximum support reaction on the hinged support of the stinger (on the first roller support after the stern part of the firing line) R_0 , in kN, is equal to [2]

$$R_0 = \frac{1}{\sin \varepsilon} \{M_s/r_s + N(1 - \cos \varepsilon) + mr_s[\sin \theta_1 \cdot \varepsilon + (\cos \theta_1 - \cos \alpha)] - \frac{qr_s}{2} (\sin \theta_1 \cdot \varepsilon - \sin \alpha \cdot \sin \beta)\} \quad (7.2-7)$$

where $\beta = \alpha + l_s/r_s \cdot 57,3^\circ = 14 + 35/283 \cdot 57,3^\circ = 21,1^\circ = 0,368$ rad. — pipeline departure angle from the stinger;
 $\varepsilon = S/r_s = 2/283 = 0,007$ рад. = $0,41^\circ$ ($S = 2$ m — distance between roller supports of the stinger) — increment of pipeline angle between roller supports;
 $\theta_1 = \alpha + \varepsilon = 14^\circ + 0,41^\circ = 14,41^\circ = 0,251$ rad. — change of pipeline angle after the first roller support;
 $m = 3890$ N/m — coated pipeline weight per unit length in the air;
 $q = 2015$ N/m — coated pipeline buoyancy force in water.

In such case, the reaction on the first roller support of the stinger R_0 , in kN, shall be taken equal to:

$$R_0 = \frac{1}{\sin 0,007} \{131/283 + 441(1 - \cos 0,007) + 3,890 \cdot 283[\sin(0,251 \cdot 0,007) + (\cos 0,251 - \cos 0,244)] - \frac{2,015 \cdot 283}{2} [\sin(0,251 \cdot 0,007) - \sin 0,244 \cdot \sin 0,007]\} = 3659 \text{ kN}. \quad (7.2-8)$$

Other force values of pipeline laying from the SULEYMAN VEZIROV PLV and geometry of the S-curve of the subsea pipeline in question for its static strength calculation may be determined based on [2] and [3].

Bending radius of the laying pipeline from the point of pipeline departure from the stinger (from the point of curvature reversal) to the point of contact with the seabed shall not be less than the value determined by Formula (7.2-1). In such case, the main parameters to determine bending radius of the pipeline (and the length of its free span accordingly) are the sea depth in the area of pipeline laying and

the geometry of stinger — its radius, length and initial angle. For example, in case of shallow waters and long stingers, when the point of pipeline departure from the stinger coincides with the point of curvature reversal, the length of pipeline free span l is determined by the following formula:

$$l = \frac{H - h_s}{1 - \cos \beta} \sin \beta \quad (7.2-9)$$

where H = sea depth in the area of pipeline laying;
 $h_s = r_s(1 - \cos(l_s/r_s))$ = distance of the end support of the stinger from the PLV waterline;
 β = pipeline departure angle from the stinger.

7.3 PIPELINE STRENGTH CALCULATION DURING PLV MOTIONS

When verifying pipeline strength during laying from PLVs, the effects of waves and currents on the PLV due to dynamic loads acting on both the PLV hull and directly on the subsea pipeline bending over the stinger shall be taken into account. These loads shall be into account to perform the following:

- strength analysis of anchor lines when positioning and moving the PLV along the pipeline route;
- strength verification of the pipeline to be laid with dynamic movements of stinger during motions of the PLV;
- strength verification of the pipeline to be laid with direct effect of waves and current.

Based on [2] motion amplitudes of SULEYMAN VEZIROV in irregular waves may be determined in accordance with Fig. 7.3-1.

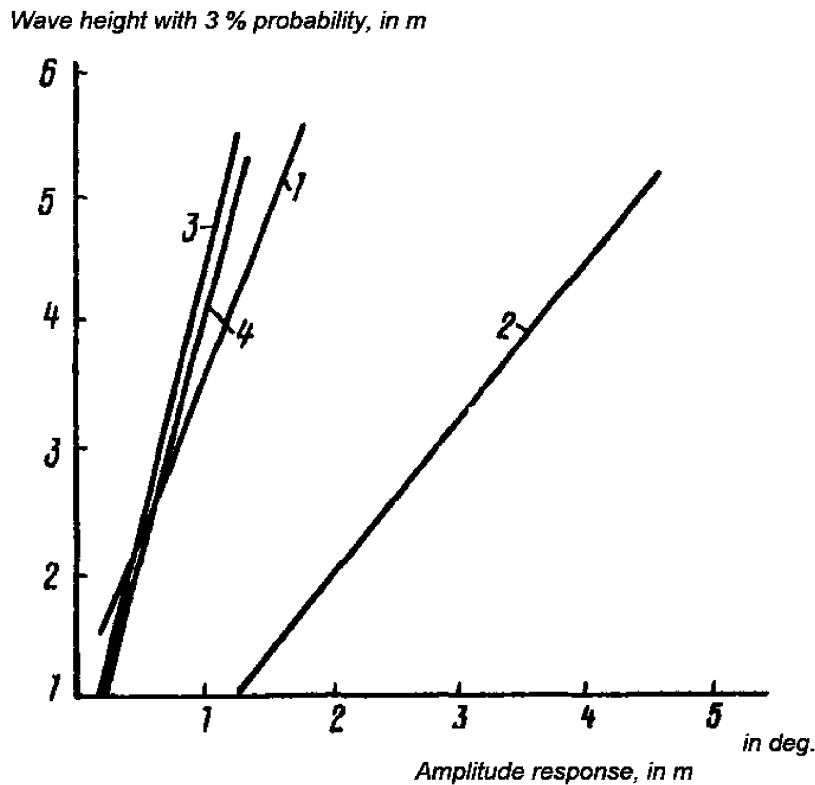

Fig. 7.3-1 Motion amplitudes of SULEYMAN VEZIROV in irregular waves with 3 % probability [2]:
 1, 2 — pitch (ψ) and roll (θ); 3, 4 — sway (a_y) and heave (a_z)

In accordance with Fig. 7.3-1, maximum motion amplitudes of this PLV when wave heights with 3 % probability do not exceed 2,5 m are as follows:

$$\begin{aligned} a_g &= 0,55 \text{ m;} \\ a_v &= 0,61 \text{ m;} \\ \psi &= 0,65^\circ \text{ (0,011 rad.);} \\ \theta &= 2,4^\circ \text{ (0,042 rad.).} \end{aligned}$$

In such case, heave amplitude response of the end roller support of the stinger G_{ev} taking into account location of the stinger and its length l_s shall be determined by the following formula:

$$G_{ev} = (L/2 + l_s)\psi + a_v + k\theta = (107/2 + 35)0,011 + 0,61 + 10 \cdot 0,042 = 2,0 \text{ m} \quad (7.3-1)$$

where $k = 10 \text{ m}$ — distance of stinger from the PLV centerline;
 $L = 107 \text{ m}$ — length of the PLV;
 $l_s = 35 \text{ m}$ — stinger length.

Sway amplitude response of the end support of the stinger is determined by formula

$$G_{eg} = a_g + h_s\theta = 0,55 + 2,83 \cdot 0,042 = 0,67 \text{ m} \quad (7.3-2)$$

where $h_s = 2,83 \text{ m}$ = distance of the end support of the stinger from the PLV waterline (refer to Formula (7.2-9)).

Thus, the pipeline string between the end roller support of the stinger and the point of contact with the seabed during laying is in forced oscillations with amplitudes determined by Formulae (7.3-1) and (7.3-2), and with a frequency of sea waves.

Verification of pipeline strength during motions of the PLV and effects of current on pipeline to be laid is specified in [2] and includes the following stages:

- generating an equation for forced oscillations of the pipeline;
- determining the natural frequency of the pipeline and check for off-resonance;
- determining the bending moment of the pipeline in vertical plane and the shearing force due to the PLV motions;
- determining the bending moment of the pipeline in horizontal plane due to current effects.

Stressed state of the subsea pipeline string in the process of laying shall be determined by the effects of bending moments, weight load, and tension force:

- in vertical plane — from pipeline's self-weight load taking into account the buoyancy force in water and the dynamic moment due to the PLV motions;
- in horizontal plane — from the effect of current and the dynamic moment resulting from PLV motions;
- hoop stresses due to hydrostatic water pressure.

The above loads acting on the subsea pipeline during its laying are used to verify the pipeline strength based on the total stress values in accordance with 8.5.6.6, Part I "Subsea Pipelines" of the SP Rules.

7.4 SPECIFICS OF STRESS-STRAIN STATE CALCULATION OF A PIPELINE INSTALLED BY S-LAY METHOD

To determine stress-strain state of pipelines during their laying on the seabed in national and foreign references an approximate differential equation for beam deflection, which is only valid for S-laying in shallow waters is generally used due to the assumption that tilt angles of pipeline sections are small. When angles and bends are large, a exact differential equation for beam deflection shall be used.

In general, the exact differential equation for beam deflection is as follows:

$$M(x) = EI \frac{d^2y/dx^2}{[1 + (dy/dx)^2]^{3/2}} \quad (7.4-1)$$

where $M(x)$ = bending moment in an arbitrary point x of the beam;
 E = modulus of the material elasticity;
 I = moment of inertia of a cross section;
 y = deflection.

This is a nonlinear second order differential equation difficult for integration. The exact deflection curve resulted from solving this equation is an elastic curve. However, this results in certain difficulties with assignment of design bending moments from all the external loads.

Alternatively, to determine the stress-strain state of subsea pipeline during its laying, a calculation method based on modern computer technologies and methods of solving appropriate boundary problems of deformable rigid body mechanics, in particular, the calculation in Mathematica symbolic computation environment may be applied [7].

7.5 APPLICATION OF STRENGTH ANALYSIS SOFTWARE OF A SUBSEA PIPELINE DURING ITS LAYING

Strength analysis software of a subsea pipeline during its laying (e.g. OFFPIPE program developed by R.C. Malahy, Jr. et al.) shall be based on finite element nonlinear simulation of the pipeline to be laid and shall provide for static and dynamic analyses of the pipeline laying process depending on water depth and tensile forces, with various configurations of supports of the PLV firing line and stinger taking into account methods of its attachment and buoyancy, including *S*-lay and *J*-lay methods.

The applied software shall provide static and dynamic analyses of initiation, abandonment/recovery of pipeline laying, raising/lowering of pipelines to the seabed using cables and buoyancy elements. In such case, the dynamic effects on the PLV due to wind, current, and sea waves, including regular and irregular waves of various directions shall be taken into account. Parameters of the PLV motions (roll, pitch, and yaw) and deflections of the PLV from the pipeline route may be taken into account.

Seabed shall be modeled as a continuous elastic-plastic foundation with the specified 3D seabed surface profile, which is determined based on engineering survey. Soil friction coefficients may be specified for both lateral and longitudinal pipe displacements.

In addition to stress-strain state analysis of the pipeline, span length and free span geometry of the pipeline to be laid during raising/lowering of the pipeline, the seabed response in the point of contact with the seabed and parameters of free spans of laid pipelines on the stages of laying, hydraulic tests and pipeline operation shall be determined.

Input data for the software packages of subsea pipeline laying numerical simulation shall include at least the following:

- length of design finite element of the pipeline;
- characteristics of the steel pipeline (diameter, wall thickness, thickness and density of insulation and concrete weight coating, pipe weight in the air and its submerged weight);
- yield strength and elasticity modulus of the pipeline steel;
- characteristics of the PLV (locations and characteristics of roller supports of roller beds and tensioners, characteristics of stinger);
- profile and characteristics of the seabed (soil friction coefficient, vertical and transverse resistance);
- sea depth, adopted parameters of wind, current and wave effects.

7.6 SYSTEMS FOR SUBSEA PIPELINE BURIAL INTO THE SEABED

Burial of subsea pipelines into the seabed soil is required due to a number of reasons, the main of which is the presence of ice gauging in the seabed due to its gouging by ice formation keels. Requirements for pipeline burial depth (or depth of trenches for pipeline laying) shall comply with the requirements of 8.3, Part I "Subsea Pipelines" of the SP Rules. To implement such a method of subsea pipeline construction, the use of post-trenching machines is recommended to perform trenching a pipeline and its backfilling without involvement of divers (diverless process) immediately after (in fact — simultaneously, with an insignificant delay) laying of the specified pipeline section (refer to Fig. 7.6-1).

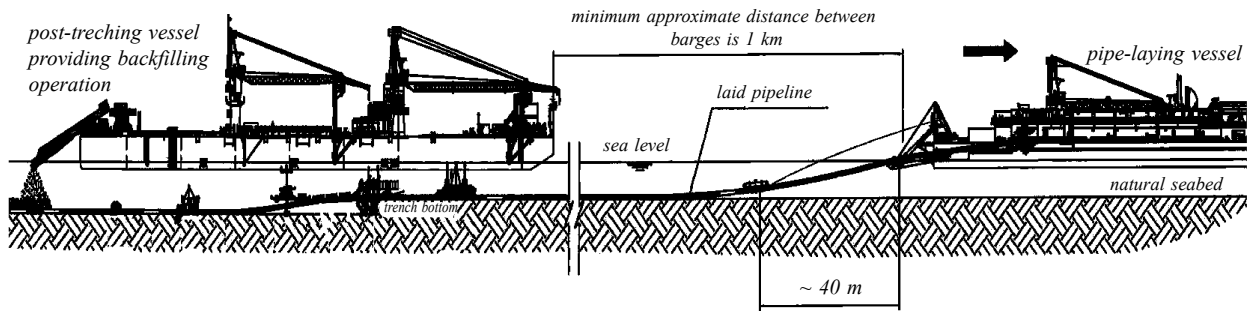

Fig. 7.6-1 Combined laying and post-trenching of a subsea pipeline with backfilling (CASTORO-12 and CASTORO-16 trenching barges of Saipem S.p.A., Italy)

Fig. 7.6-2 illustrates an example of a power-driven post-trenching system developed by Saipem S.p.A. for installation on the CASTORO-16 post-trenching barge (refer to Fig. 7.6-1). This system includes at least two units. The first unit (trenching sled) (in the direction of trenching) is intended for trenching under the pipeline using two helical blade cutting tools coupled with two DN 400 mud hoses of the dredging pump station installed on the vessel. Trenching sled is driven by 1-MW hydraulic drive and provides trench depth of up to 3,7 m. Trenching sled requires application of an additional pulling unit, as a rule, of a track type. The second unit (suction unit) is intended for correction of the trench profile and provided with a track drive with 350 kW hydraulic drive, a mud hose of dredging pump station, and tools to monitor the trench profile and the pipeline position, including guide rollers moving along the pipeline. Total capacity of the system is 3600 m³/h.

The above-mentioned system may be provided with backfilling unit intended for backfilling of the pipeline laid into the trench using the spoil material removed from the trench (the system to store and supply spoil and water mixture for backfilling shall be installed onboard the vessel, to which this system is structurally connected).

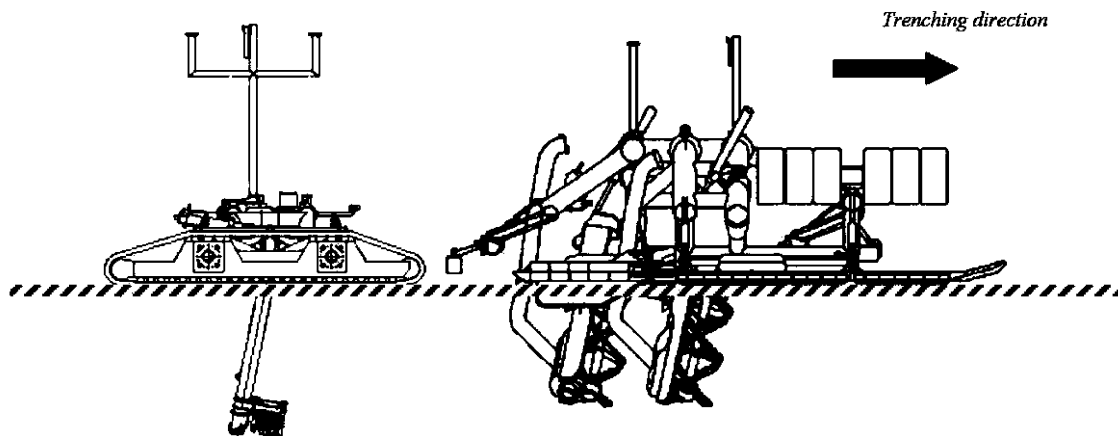

Fig. 7.6-2 Post-trenching system developed by Saipem S.p.A.

Fig. 7.6-3 illustrates the system developed by Saipem S.p.A. provided with sliding buoys to support the pipeline avoiding overstress when placing it to the trench profile, combined with track driving unit.

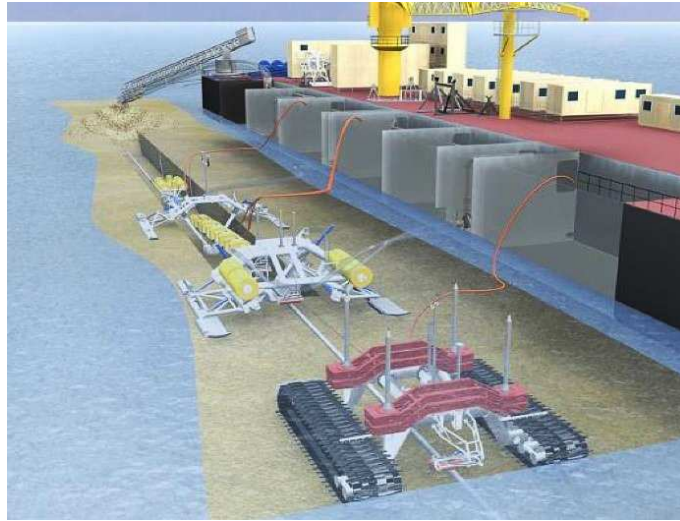

Fig. 7.6-3 Combined system for post-trenching and backfilling of a subsea pipeline developed by Saipem S.p.A.

It shall be taken into account that this combined system provides not only dredging a trench with predefined parameters and safe placing of a previously laid subsea pipeline, but also backfilling the pipeline using the spoil material removed from the trench. In such case, the loss of backfilling soil in the process of its excavation and supply back to the trench is about 20 %.

The technologies specified in Section 10 may be used for pipeline trenching.

REFERENCES

1. Marine Pipe-Laying Vessels. — Saint-Petersburg: FSUE Krylov State Research Center, 2016.
2. R 412-81 Recommendations for Design and Construction of Subsea oil and Gas Pipelines. — Moscow: VNIIST, 1981.
3. R 537-84 Guidelines on Laying and Burying of Pipelines in Reservoirs and Large Rivers. — Moscow: VNIIST, 1984.
4. Concept of Strength Analysis of Main pipelines for Underwater Passages Made of Concrete Coated Pipes. — News of Machine Building Industry, 2015, No.7, p. 11 — 16.
5. GOST R 54382-2011 Oil and Gas industry. Submarine Pipeline Systems. General Requirements.
6. Strain-Stress State Analysis of Pipelines Made of Concrete Coated Pipes with Ring Slots. — Gas industry, 2017, No.11, p. 68 — 73.
7. Papusha A.N. Designing of Offshore Submarine Pipeline: Calculation for Strength, Bending and Stability of Offshore Pipeline in Mathematica — Moscow: Gubkin Russian State University of Oil and Gas, 2006.
8. Borodavkin P.P., Berezin V.L., Shadrin O.B. Submarine Pipelines. Moscow: Nedra, 2004.
9. Borodavkin P.P. Offshore Oil and Gas Facilities. Parts 1 and 2. —Moscow: Nedra, 2006;
10. Vasiliev G.G., Goryainov Yu.A., Bespalov A.P. Construction of Offshore Pipelines. — Moscow, Gubkin Russian State University of Oil and Gas, 2015.
11. Kapustin K.Ya., Kamyshev M.A. Construction of Offshore Pipelines. — Moscow: Nedra, 1982.
12. Vlasov A.A. Technical Operation of Dredging Fleet. — Moscow: Transport, 1986.
13. Yong Bai. Subsea Pipelines and Risers, Elsevier Science, 2010.

8 ELECTROCHEMICAL PROTECTION OF SUBSEA PIPELINE

8.1 INITIAL DATA FOR CALCULATION OF ELECTROCHEMICAL PROTECTION OF PIPELINES

Electrochemical methods of protection against corrosion of underwater parts of steel structures of marine hydraulic structures are based on the cathodic polarization of metal to be protected by external electric current (cathodic protection) or by current of galvanic anodes (galvanic anode system).

The main parameters of electrochemical protection are the electrode potential of the structure and the current density on the protected surface.

Data required for calculation of the electrochemical protection of the pipeline and the numerical values of these parameters for the sample calculation is provided in Table 8.1.

Table 8.1

Data for calculation of electrochemical (sacrificial) protection of pipeline

Outside diameter of pipeline, in mm	350
Pipe wall thickness, in mm	12
Pipeline length, in km	145
Sea depth, in m	11,2
Thickness of concrete weight coating, in mm	80
Maximum product temperature in pipeline, in °C	50
Type of galvanic anode	Bracelet
Aluminum-based galvanic anode alloy	AP4N
Design temperature of galvanic anode, in °C (for non-buried pipeline, it is taken to be equal to average temperature of seawater)	11
Galvanic anode efficiency factor u	0,8
Pipe length L_{tot} , in m	12
Average destruction (damage) ratio of external factory corrosion-protection coating f_{cm}	0,01625
Destruction ratio of external factory corrosion-protection coating at end of service life f_{cd}	0,0245
Average thickness of external factory corrosion-protection coating 3LPE t_{coat} , in mm	4,0
Protection potential of steel (with respect to silver chloride electrode) E_s , in V	-0,8
Potential of galvanic anode in closed circuit E_c , V	-1,05
Current density i_{cor} , in A/m ²	0,046
Density of galvanic-anode material AP4N ρ_0 , in kg/m ³	2800
Electrochemical capacity at specified current density and average annual temperature of seawater of 11 °C, ϵ , in A-h/kg	1300
Design service life of subsea pipeline t_f , years	33
Resistivity of seawater at average annual temperature of 11 °C, ρ , in Ohm-m	0,5

8.2 DETERMINATION OF TOTAL WEIGHT OF GALVANIC ANODES

The surface area of the pipeline protected by galvanic anodes is equal to:

$$A_c = \pi D_a L_{tot} = 3,14 \cdot 0,35 \cdot 145000 = 159355 \text{ m}^2 \quad (8.2-1)$$

where $L_{tot} = 145000$ m length of protected pipeline section;
 $D_a =$ outside diameter of steel pipe, in m.

The required current for the pipeline for the service life of the galvanic anodes is determined by the following formula:

$$I_{cm_tot} = A_c \cdot i_{cor} \cdot f_{cm} = 159355 \cdot 0,046 \cdot 0,01625 = 119,1 \text{ A} \quad (8.2-2)$$

where $i_{cor} = 0,046$ A/m² — design current density at average annual water temperature of 11 °C (refer to Table 8.4-2);
 $f_{cm} = 0,01625$ — average destruction (damage) ratio of insulating coating determined by Formula (8.4-1) and Table 8.4-4 for a pipeline with concrete weight coating, corrosion-protection coating 3LPE, heat-shrinkable sleeves (HSS) at pipe joints and without fillers of field joint.

The total weight of galvanic anodes is determined by the following formula:

$$M = \frac{l_{cm} \cdot t_f \cdot 8760}{u \cdot \varepsilon} = \frac{119,1 \cdot 33 \cdot 8760}{0,8 \cdot 1300} = 33110 \text{ kg} \quad (8.2-3)$$

where t_f = service life of pipeline, years;
 ε = electrochemical capacity (refer to Table 8.1);
 $u = 0,8$ — galvanic anode efficiency factor.

8.3 CALCULATION OF NUMBER AND PRELIMINARY GEOMETRY OF GALVANIC ANODES

Based on the relevant procedure [6], a number of the galvanic anodes and their preliminary geometry may be determined.

A number of galvanic anodes is calculated for the specified spacing:

$$N = CEIL(L_{tot}/L) = CEIL(145000/12 \cdot 15) = 805 \text{ pcs.} \quad (8.3-1)$$

where $CEIL$ = function of rounding up to the whole number from the value obtained as a result of the calculation;
 L = product length of one pipe ($L = 12,0$ m) by the specified spacing (spacing of galvanic anodes is taken to be $5 \div 25$, in this case — 15).

Weight of one galvanic anode M_{tot} is determined by the following formula:

$$M_{tot} = M/N = 33110/805 = 41,1 \text{ kg} \quad (8.3-2)$$

where M = total weight of the galvanic anodes, in kg;
 N = number of galvanic anodes.

Initial volume of galvanic anode V_i is determined by the following formula:

$$V_i = M_{tot}/\rho_0 = 41,1/2800 = 0,015 \text{ m}^3 \quad (8.3-3)$$

where M_{tot} = weight of the galvanic anode, in kg;
 ρ_0 = density of the galvanic anode material, in kg/m³.

Required length of galvanic anode L_a is determined by the formula:

$$L_a = \frac{V_i}{\pi/4[(D_{int} + 2t_a)^2 - D_{int}^2] - 2t_a \cdot gap} \quad (8.3-4)$$

where t_a = thickness of galvanic anode equal to a thickness of the concrete coating of 8 cm;
 $gap = 10$ cm — distance taken between the halves of the bracelet galvanic anode (generally, $5 \div 10$ cm);
 D_{int} = internal diameter of galvanic anode, in m;

$$D_{int} = D_a + 2t_{coat} = 0,35 + 2 \cdot 0,004 = 0,358 \text{ m} \quad (8.3-5)$$

where D_a — outside diameter of steel pipes, in m;
 $t_{coat} = 0,004$ m — average thickness of corrosion-protection and insulation coating (if the latter is used).

In such case, the required length of galvanic anode L_a is determined by the formula

$$L_a = \frac{0,015}{\pi/4[(0,358 + 2 \cdot 0,08)^2 - 0,358^2] - 2 \cdot 0,08 \cdot 0,06} = 0,15 \text{ m.} \quad (8.3-6)$$

Final wall thickness of galvanic anode t_{ef} is determined by the following formula:

$$t_{ef} = (1 - u)t_a = (1 - 0,8)0,08 = 0,016 \text{ m.} \quad (8.3-7)$$

The required current for the pipeline at the end of the galvanic anode service life according to Formula (8.2-2) is equal to:

$$I_{cftot} = A_c \cdot i_{cor} \cdot f_{cd} = 159355 \cdot 0,046 \cdot 0,0245 = 179,5 \text{ A}$$

where f_{cd} = destruction (damage) ratio of insulating coating at end of service life and determined by Formula (8.4-2) and Table 8.4-4 based on the corrosion-protection scheme specified for Formula (8.2-2).

The surface area of the galvanic anode at the end of the service life is determined by the following formula:

$$A_{af} = [\pi(D_{int} + 2t_{ef}) - 2gap]L_a = [\pi(0,358 + 2 \cdot 0,016) - 2 \cdot 0,10]0,15 = 0,153 \text{ m}^2. \quad (8.3-8)$$

Electrolytic resistance of the galvanic anode at the end of service life is determined by formula

$$R_{af} = 0,315\rho / \sqrt{A_{af}} = 0,315 \cdot 0,5 / \sqrt{0,153} \text{ Ohm} \quad (8.3-9)$$

where ρ = resistivity of seawater, in Ohm·m (refer to Table 8.1).

Galvanic anode current at the end of the service life I_{af} is determined by formula

$$I_{af} = \Delta E / R_{af} = (-1,05 + 0,8) / 0,402 = 0,62 \text{ A} \quad (8.3-10)$$

where ΔE = difference between the potential of galvanic anode in closed circuit and the protection potential of steel.

Final number of galvanic anodes N_f taking into account the galvanic anode current at the end of the service life is determined by the following formula and is equal to:

$$N_f = I_{cftot} / I_{af} = 178,5 / 0,62 = 288 \text{ pcs.} \quad (8.3-11)$$

The calculation is valid if a number of galvanic anodes taking into account the current at the end of service life determined by Formula (8.3-11) is fewer than that determined by Formula (8.3-1) for the selected spacing of galvanic anode installation, i.e. $N_f = 288 \text{ pcs.} < N = 805 \text{ pcs.}$

If a number of galvanic anodes determined based on the current value at the end of service life is greater, the spacing shall be reduced or a length of the galvanic anode increased and the calculation according to Formulae (8.3-1) — (8.3-11) performed again until the required number of galvanic anodes according to Formula (8.3-11) reaches the maximum number of galvanic anodes according to Formula (8.3-1), but not exceeds this value.

8.4 RECOMMENDATIONS FOR DESIGN OF GALVANIC ANODE SYSTEM

Galvanic anode layout on the subsea pipeline with concrete weight (ballasting) coating is provided in Fig. 8.4-1. It shall be noted that due to structural considerations, the outside diameter of the galvanic anode is selected equal to a diameter of concrete weight coating of the pipeline. Bracelet galvanic anode is installed on corrosion-protection or insulation coating at the stage of factory manufacture of pipes (generally, at the stage of applying concrete weight coating). To ensure installation of the galvanic anode, the thickness tolerances of the corrosion-protection and/or insulation coatings shall be taken into account, for which the positive tolerance of at least 0/+ 4 mm shall be specified for the inside diameter when manufacturing the galvanic anode and 0/+ 1 % of nominal inside diameter for the nominal size greater than 610 mm. In other cases, the requirements for galvanic anodes in terms of requirements for geometrical parameters and quality manufacture shall comply with the requirements of ISO 15589-2 [1].

In national practice, galvanic anodes made of aluminum-based alloy AP4N according to TS 5.394-11785-2001 are used most widely to protect subsea pipelines.

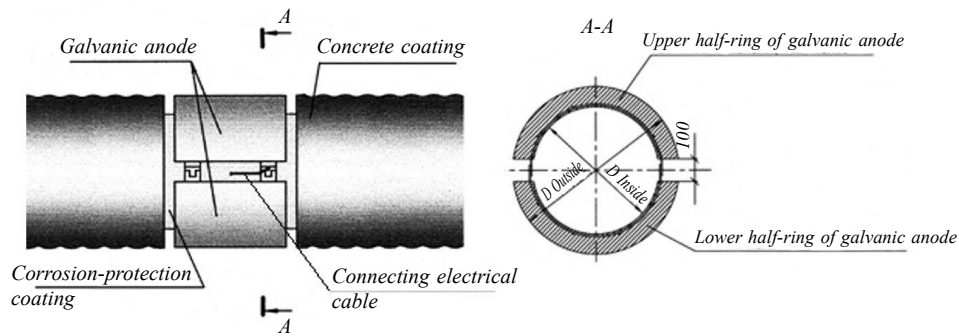

Fig. 8.4-1 Installation diagram of galvanic anode on concrete coated pipeline

It is necessary to provide reliable electric contact of the galvanic anode with the pipe body, which is done by installing connecting cables (usually, two on each side with the corrosion-protection coating being restored at the cable connection points), as well as sufficient shear strength of the galvanic anode attachment as the pipes fitted with galvanic anodes pass, when they are laid, through the actuator of the pipelay tensioner. The latter is achieved i.e. by pouring filler into the resulting gaps between the galvanic anode and concrete coating: bitumen polymer mastic, polyurethane compound, etc.

When using non-concrete coated pipes for the pipeline, the installation of galvanic anodes is usually carried out on the pipelayer at the locations of the process lines after the tensioning device. An installation diagram of the bracelet galvanic anode on a non-concrete coated pipe with the use of welded connecting plates with the mandatory restoration of corrosion-protection coating in their installation areas is shown in Fig. 8.4-2.

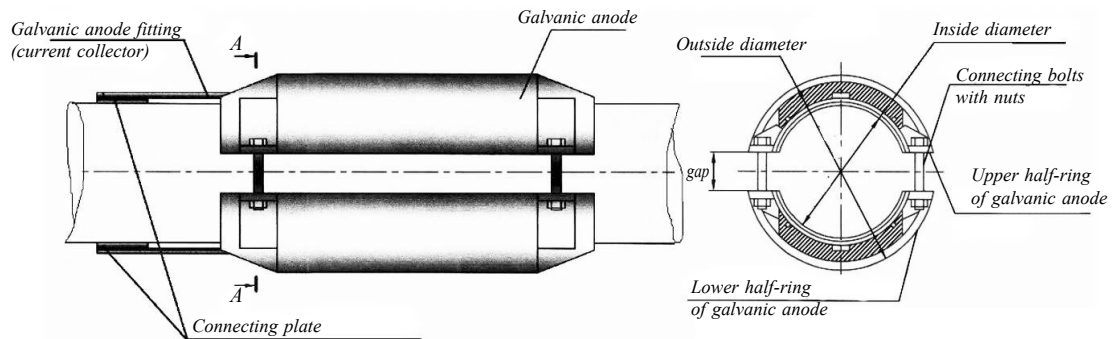

Fig. 8.4-2 Installation diagram of galvanic anode on non-concrete-coated pipeline

The required protection level of subsea pipelines is regulated by the protection potential that shall be equal to $-0,8$ V, and the maximum protection potential relative to the silver chloride electrode shall be equal to $-1,1$ V. Table 7.4-1 illustrates, according to [1], a difference in values of protection potentials for carbon steel pipelines buried and not buried into the seabed is specified in Table 8.4-1 [1].

Table 8.4-1

Protection potentials of offshore carbon steel pipelines

Pipeline location	Minimum negative potential, in V	Maximum negative potential, in V
Buried into the seabed soil	$-0,90$	$-1,10$
Non buried into the seabed soil	$-0,80$	$-1,10$

Another critical protection criterion is the protection current density. Protection current density is assigned in accordance with normative documents (e.g. [8], [10]). Values of protection current densities in different environmental conditions for subsea pipelines are specified in Table 8.4-2.

Table 8.4-2

Protection current densities in different environmental conditions for subsea pipelines

Mean protection current density, in mA/m ²	Conditions	Seawater depth, in m	Seawater temperature, in °C
30 — 140	without current	up to 20	5 — 30
90	moderate flow (up to 2 m/s)	up to 500	10 — 18
180	moderate flow (up to 2 m/s)	up to 1500	5 — 10
380	strong current (over 2 m/s)	all depths	2
300	moderate flow (up to 2 m/s)	up to 1500	-1 — 4

Thus, the design current densities depend on the seawater temperature, oxygen content and current velocity. For most applications in water depth of less than 500 m, the design current densities depend only on the seawater temperature, and the current densities for a non-buried pipeline shall correspond to those specified in Fig. 8.4-3 [1].

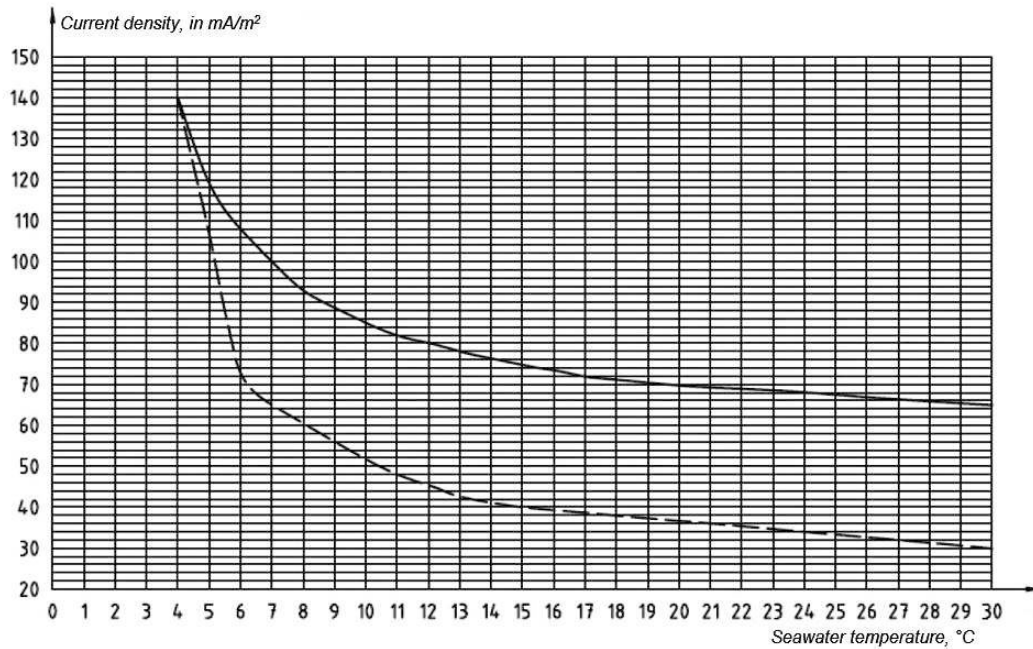

Fig. 8.4-3 Dependence of mean current density on seawater temperature

The lower current-density curve shall be used in case there are no significant changes in the oxygen content at the seawater depth and moderate seabed currents (up to 1 m/s). The upper curve is used when the oxygen content and significant velocities of the seabed currents are taken into account.

For fully buried pipelines, a design current density (mean and final) of 20 mA/m² shall be used irrespective of the oxygen content, seawater temperature or depth.

Pipelines operating at temperatures exceeding 25 °C on the outside surface of the pipe require adjustment of the design current density. Where the metal/ambient temperature increases, the design current densities shall be increased by 1 mA/m² for each degree Celsius above 25 °C up to 100 °C. In such case, a temperature of the galvanic anode surface shall be taken equal to the ambient temperature of the pipeline for non-buried pipelines. For buried pipelines, the surface temperature of the galvanic anodes shall be specified according to a temperature of transported medium.

For a coated pipeline, the protection current demand increases with time as the coating deteriorates. Sufficient cathodic protection capacity shall be provided to maintain protection as the coating deteriorates.

The mean coating breakdown factor f_{cm} is determined by the formula

$$f_{cm} = f_i + (0,5\Delta f \cdot t_f) \tag{8.4-1}$$

The final coating breakdown factor f_{cd} is determined by the formula

$$f_{cd} = f_i + (\Delta f \cdot t_f) \tag{8.4-2}$$

where f_i = initial coating breakdown factor at the beginning of the pipeline operation;
 Δf = average annual increase in the coating breakdown factor;
 t_f = design life of coating (pipeline), in years.

The coating breakdown factors for subsea pipelines without and with concrete weight coatings are provided in Tables 8.4-3 and 8.4-4 respectively [1].

Table 8.4-3

Corrosion-protection coating breakdown factors for subsea pipelines without concrete weight coating

Factory-applied coating type	Field joint coating type	f_i	Δf
FBE (fusion-bonded epoxy)	Heat-shrinkable sleeve (HSS)	0,080	0,0035
	FBE	0,060	0,0030
3LPE (three-layer polyethylene coating)	HSS	0,009	0,0006
	FBE	0,008	0,0050
	3LPE	0,007	0,0005
3LPP (three-layer polypropylene coating)	HSS	0,007	0,0003
	FBE	0,006	0,0002
	3LPP	0,005	0,0002
Heat insulation multi-layer coatings including PE, PP or PU	Thick multi-layer coatings including PE, PP, PU, HSS, or combination of these products	0,002	0,0001

Table 8.4-4

Corrosion-protection coating breakdown factors for subsea pipelines with concrete weight coating

Factory-applied coating type	Field joint infill	Field joint coating type	f_i	Δf
FBE (fusion-bonded epoxy)	no	HSS	0,045	0,0025
		FBE	0,035	0,0020
	yes	HSS	0,040	0,0020
3LPE (three-layer polyethylene coating)	no	HSS or FBE	0,008	0,0005
		3LPE	0,007	0,0003
	yes	HSS or FBE	0,004	0,0002
		3LPE	0,004	0,0002
3LPP (polypropylene coating) three-layer	no	HSS or FBE	0,008	0,0005
		3LPP	0,007	0,0003
	yes	HSS or FBE	0,004	0,0002
		3LPP	0,004	0,0002

For concrete coated pipelines with insulation, the coating breakdown factors shall be assigned according to Table. 8.4-3 in case of multi-layer insulation coatings.

REFERENCES

1. ISO 15589-2:2012. Petroleum, Petrochemical and Natural Gas Industries — Cathodic Protection of Pipeline Transportation Systems — Part 2: Offshore Pipelines.
2. GOST R 54382-2011 "Oil and Gas industry. Submarine Pipeline Systems. General Requirements".
3. DNVGL-RP-F103 Cathodic Protection of Submarine Pipelines.
4. DNVGL-RP-B401 Cathodic Protection Design.
5. RD 31.35.07-83 Guidelines for Electrochemical Anti-Corrosion Protection of Underwater Metal Structures of Offshore Hydroengineering Facilities.
6. Vasiliev G.G., Goryainov Yu.A., Bespalov A.P. Construction of Offshore Pipelines. Gubkin Russian State University of Oil and Gas, 2015.
7. VSN 009-88 Construction of Trunk and Field Pipelines. Means and Installation of Electrochemical Protection, 1990.
8. R Gazprom 9.2-015-2012. Requirements for Electrochemical Protection of Offshore Structures. Moscow, Gazprom JSC, 2014.
9. R Gazprom 9.2-038-2014. Procedure for Calculation of Cathodic Protection Parameters of Gazprom JSC Offshore Facilities (Pipelines, Port Facilities, Subsea Production Systems and Offshore Platforms), 2017.
10. R Gazprom 9.2-026-2014 Protection Against Corrosion. Guidelines for Organization of Electrochemical Protection of Gazprom JSC Offshore Pipelines.

9 RESULTS OF SAMPLE CALCULATIONS

Overall results of the calculations performed to determine design parameters of subsea pipeline and its route selected as a sample are provided in Table 9.1.

Table 9.1

Results of calculations to determine design parameters of subsea pipeline

Pipeline parameter	Value
Greatest pipeline subsidence into seabed soil	11,5 cm
Design pressure in pipeline	8,0 MPa
Greatest effect due to current	73,1 N/m
Greatest effect due to waves:	
horizontal load	505,09 N/m
vertical load	1271,08 N/m
Pipeline wall thickness	12 mm
Weight of ballasting coating for 1 lin. m in water	2,55 kN/m
Density of the concrete weight coating	2700 kg/m ³
Recommended type of galvanic anode and its material	Bracelet, aluminum alloy AP4N
Number of galvanic anodes required to protect pipeline	805 pcs.
Service life of pipeline (galvanic anode)	33 years
Spacing of galvanic anodes	180 m
Thickness of galvanic anode	80 mm
Outside diameter of galvanic anode	510 mm
Weight of galvanic anode	41 kg
Length of galvanic anode	150 mm

10 METHODS OF SHORE CROSSING BY SUBSEA PIPELINES

10.1 GENERAL REQUIREMENTS FOR SUBSEA PIPELINE SHORE CROSSING

During design of offshore pipeline systems, the construction facility is divided into the following construction areas according to work procedures and equipment: main, landfall wet sections and shore crossing (refer to Fig. 10.1-1).

On the main work site, pipe-laying vessels of generations III and IV capable of laying pipelines from depths of 20,0 m and deeper may be used. In landfall wet sections, pipe-laying vessels of generation II capable of laying approximately from the 5,0 m isobath may be used, and in shore crossing areas, laying is performed, as a rule, by pulling the pipeline using any given method.

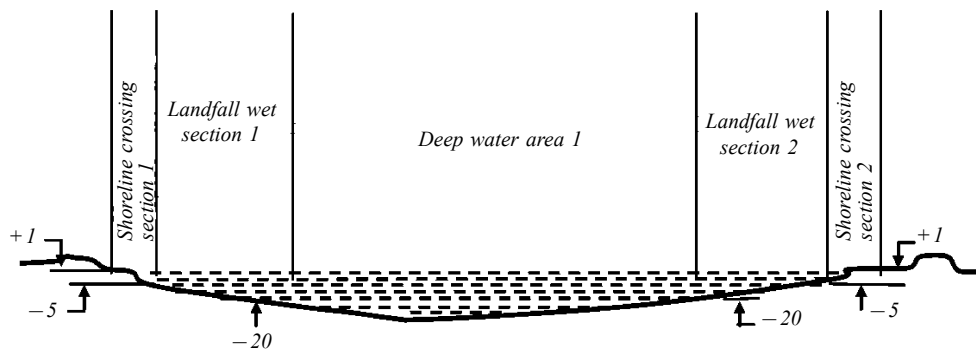

Fig. 10.1-1 Sections of offshore pipeline route [3]

In the construction of offshore pipelines, one of the most critical and labor-intensive areas of work is the shore crossing area. Construction work is characterized by engaging various types of construction equipment and applying various work procedures.

Currently, there is no regulatory documentation or methodological instructive regulations in the Russian Federation related to work performance at the subsea pipeline shore crossing, which leads to the fact that, during design implementation, the procedure taken for shore crossing is often unique to every project. The requirements for crossings of subsea pipelines with shorelines are specified in 8.2.4, Part I "Subsea Pipelines" of the SP Rules.

The following possible characteristic features for shore crossing shall be taken into account when selecting the shore crossing method:

- strong wave action on the site;
- soil erosion on the construction site (tides, currents);
- possible effect of ice formation keels in seabed exaration;
- economic activities (effect of fishery gear, anchors, etc.);
- need for additional measures to provide the pipeline stability.

All these specific features, as a rule, lead to the need for pipeline burial in the given section of the route.

When reviewing the specifics of landfalls, attention shall be paid to a boundary between offshore and onshore sections. Generally, the following is taken as such a boundary:

- flanged (or welded) connection of the first shut-off valve after the landfall;
- flanged (or welded) connection of an electrically insulating joint that electrically separates the onshore and offshore areas;
- flanged (or welded) connection of pig receiving/launching station.

10.2 METHODS OF SHORE CROSSING WHEN LAYING OFFSHORE PIPELINES

As a result of the analysis of shore crossings, the principal methods of shore crossing in construction of offshore pipelines include the following:

- pipeline laying in preliminarily excavated trench in the landfall wet sections and on the shore crossing section;
- using horizontal directional drilling method (HDD);
- using tunneling method.

A pipeline is laid in a trench using one of the following pull methods (Fig. 10.2-1):

- pipeline is mounted on a pipe-laying vessel and pulled ashore using a pipe-laying vessel winch and reverse pulley located on the shore;
- pipeline is mounted on pipe-laying vessel on the sea and then pulled ashore using winches on the shore;
- pipeline is mounted on the shore and pulled into the sea using pipe-laying vessels (or specialized watercraft: process platform, pontoon, etc.) equipped with winches.

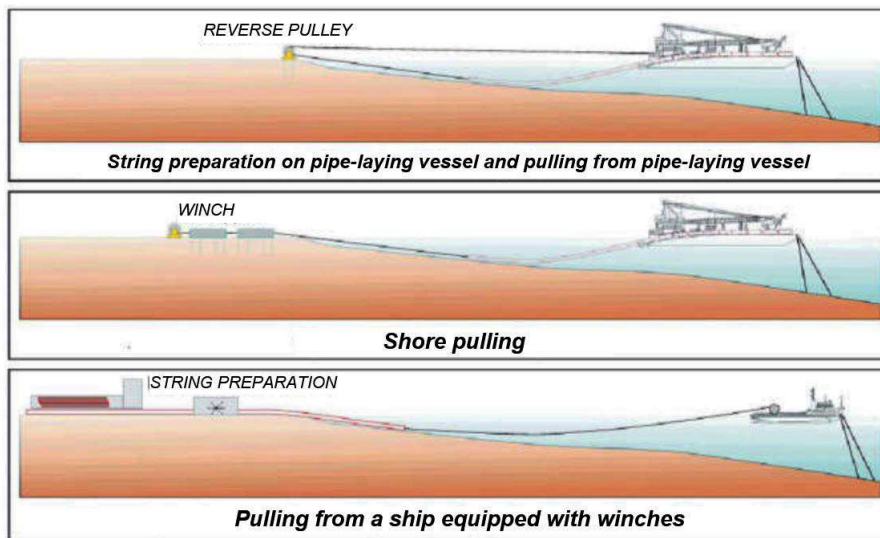

Fig. 10.2-1 Pipeline laying methods of pulling pipeline in construction of shore crossing [3]

Preparation of a trench and the installation by pulling from the shore in the inundated onshore section of subsea pipelines more than 8 km long in the northern part of the Caspian Sea. A pipeline string was formed on pipe-laying vessel, backfilling was performed by grab dredger.

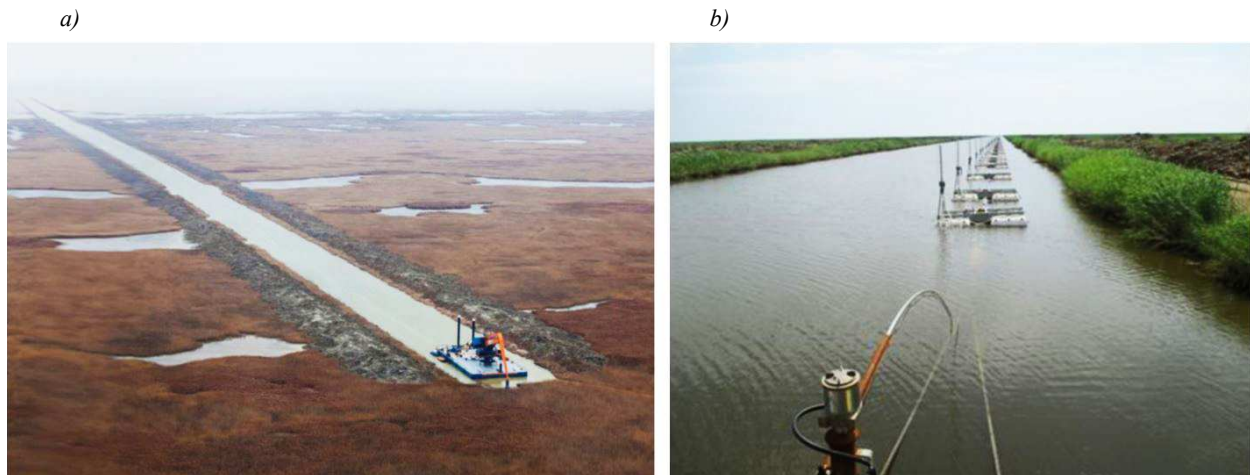

Fig. 10.2-2 Grab dredger Titan when trenching (a) and pulling afloat pipeline from shore (b)

Selection of trenching method depends on seabed soil properties (refer to Fig. 10.2-3).

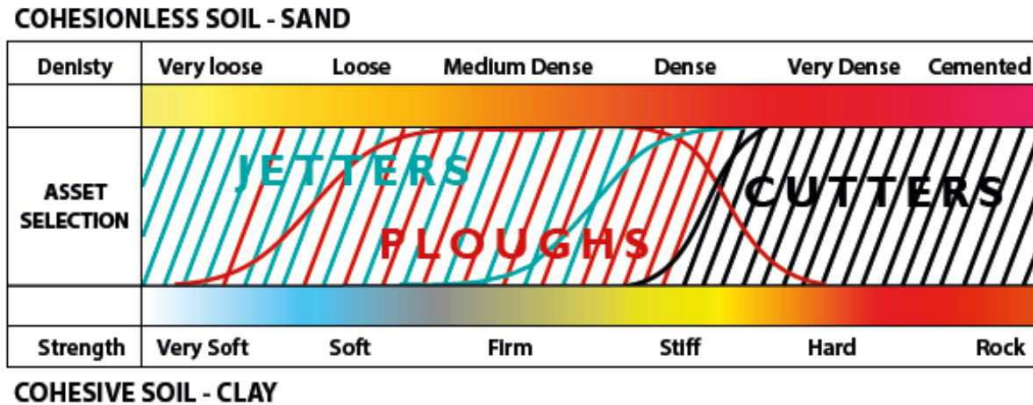

Fig. 10.2-3 Selection of trenching method [1]

In some cases, a cofferdam — a structure usually in the form of a sheet-pile wall that provides the integrity of the trench and protects the pipelines under construction against wave effects and trench washing-out — is constructed in the trench to install the subsea pipeline in the shoreline area (refer to Fig. 10.2-4). Upon completion of pipeline laying and backfilling, the entire cofferdam structure shall be dismantled.



Fig. 10.2-4 Cofferdam for pulling of pipeline on shore at the Kirinskoye field, Sakhalin Island

The route, the shore crossing area and the burial depth of the subsea pipeline into the seabed soil are selected so as to reduce the effect of tectonics on the operability and reliability of the pipeline.

Among the dynamic phenomena that occur in the sea ice cover, a special place is taken by large ice formations drift movement, which in interaction with the seabed, may result in its gouging, especially in the area of the subsea pipeline landfall. In water areas with seasonal ice cover (the freezing Caspian, Baltic, Okhotsk Seas, etc.) and on the marine Arctic shelf (the Barents, Pechora, Kara Seas, Baydaratskaya Bay, etc.), a depth of the subsea pipeline along the route, including in the shoreline crossing area shall meet the requirements of 8.3, Part I "Subsea Pipelines" of the SP Rules, where presence of ice gouging is revealed instrumentally (underwater TV survey, sonar survey, diver survey).

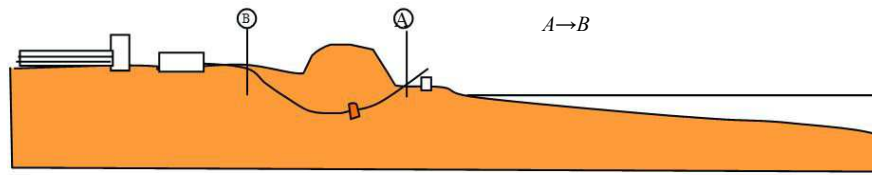

1. HDD on shore side with trenching in near-shore area

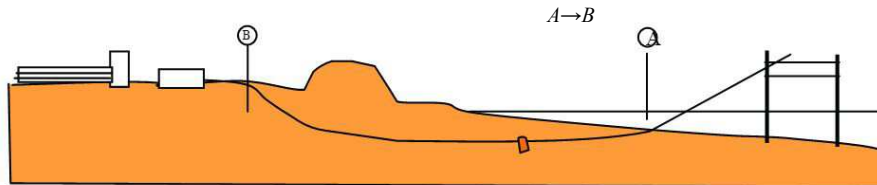

2. HDD from drilling rig installed on offshore drilling platform

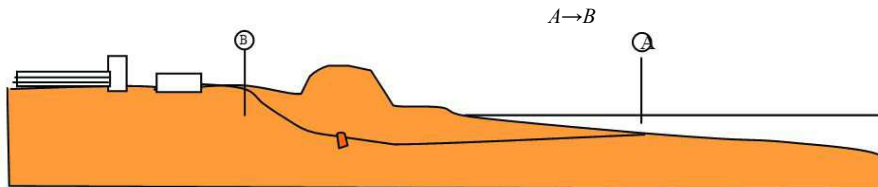

3. HDD from land towards offshore

Fig. 10.2-5 HDD methods at shoreline crossing [3]

In some cases, it is more appropriate to replace the open trench method on the site with the shoreline crossing using HDD method. The HDD method is used in cases where efficient earthworks cannot be performed due to geological conditions. This method makes it possible to cross the cliffed shore, as well as onshore facilities. The shore crossing that uses HDD is characterized by the least damage to the environment as compared to the open trench method. The above methods of pulling are also used when pulling a pipeline into a well prepared by using HDD or into a tunnel.

The construction of onshore sections of subsea pipelines using the HDD method is preferable when there are steep shores, strong currents and significant wave effects, which makes the construction of trenches for pipeline burial very difficult (refer to Fig. 10.2-5). In addition, the pipeline construction using the HDD method in the shore crossing area may also be caused by the presence of bedrock with ridges in the shore crossing areas that requires the pipeline burial and the need to lay the pipeline through a significant number of utilities.

Generally, the pipeline is laid in a protective casing when using the HDD method. For this purpose, a steel casing pipe can be used that is installed throughout the length of the HDD well. The protective casing ensures that there is no damage to or blockage of the pipeline during installation, and there is also no risk that the bore hole walls would collapse.

When using the HDD method, the following shall be taken into account:

- retention and removal of drilling mud;
- sectioning of corrosion-protection coating system of the pipeline with high resistance to abrasion and low surface friction;
- providing of the pipeline stability before pulling it into the drilled well.

REFERENCES

1. Decommissioning of Pipelines in the North sea region/Association Limited, trading as Oil & Gas UK, Aberdeen, 2013.
2. Recommendations for safety assessment of gas pipeline during design. Moscow: Gazprom JSC, 2000.
3. Vasiliev G.G., Goryainov Yu.A., Bespalov A.P. Construction of offshore pipelines. Moscow, Gubkin Russian State University of Oil and Gas, 2015;
4. SP 36.13330.2012 Trunk pipelines. Revised edition of SNIIP 2.05.06-85*.
5. SP 86.13330.2014 Trunk pipelines. Revised edition of SNIIP III-42-80*.
6. SP 108-34-97 Construction of underwater crossings.
7. DNVGL-ST-F101 Submarine Pipeline Systems, 2017.

11 METHODS OF SUBSEA PIPELINE CROSSING

11.1 REQUIREMENTS OF REGULATORY DOCUMENTS FOR SUBSEA PIPELINE CROSSING

This Section contains the requirements of national and international normative documents related to pipeline crossings, including subsea pipeline crossings with other pipelines and cables: SP 36.13330.2012 [4], SP 86.13330.2014 [5], SP 18.13330.2011 [10], GOST R 54382-2011 [6], GOST R ISO 13623: 2009 [7], DNVGL-ST-F101 [12], ABS [15], LR [16], ASME B31.4 [13], BS 8010:3 [14] (refer to Tables 11.1-1 and 11.1-2).

Table 11.1-1

Requirements for subsea pipeline crossing

National				
SP 36.13330.2012	SP 86.13330.2014	GOST R 54382-2011	SP 18.13330.2011	GOST ISO 13623:2009
Crossing angle of at least 60°. Clear distance between pipelines of at least 0,35 m	Laying of pipelines under construction by pulling under the existing utilities	Clear distance between pipelines of at least 0,3 m. Installation of supporting structures or gravel bed	Clear distance between pipelines is 0,2 — 0,4 m. Clear distance between pipelines and cables of at least 0,5 m.	Crossing angle is 90°. Installation of concrete mats and other structures to keep constant separation (where necessary)
International				
DNVGL-ST-F101	ABS	LR [16]	ASME B31.4-2016	
Crossings between pipelines and pipelines and cables shall be kept separated by a minimum vertical distance of 0,3 m. Assessment of possible electrical interferences and their consequences is required.	Vertical separation at crossings between new and existing pipelines shall be at least 1,0 ft (0,3 m) as required in ASME B31.4. The pipeline crossing profile shall be checked for local loads, operating and external loads. The stability of supports shall be checked for sliding and for overturning moment. Crossing design shall be also taken into account soil bearing capacity and the requirements for additional supports to minimize or avoid the creation of unsupported span.	In general, pipeline or cable crossing shall be avoided. Where a pipeline or cable crossing is essential, the operator of the pipeline or cable to be crossed shall be consulted and method, location and timing of the crossing shall be agreed upon by both operators. Possible interaction of the cathodic protection system of two pipelines shall be considered. The crossing shall be designed in such a manner that a physical separation between the two pipelines exists all times.	Pipeline crossings shall be designed to provide a minimum 12-in. (300 mm) separation between two utilities. Dielectric separation of the two pipelines shall be considered in design of pipeline crossings. Soil subsidence, scour and cyclic loads shall be taken into account considered in the design of pipeline crossings in order to ensure that the separation is maintained for the design life of both lines.	

Requirements for crossings of pipelines and cables non-buried and buried into the seabed soil developed based on comparative analysis of the above-mentioned documentation and experience of the design documentation review by RS are specified in 8.2.3, Part I "Subsea Pipelines" of the SP Rules.

Table 11.1-2

Requirements of international normative documents related to subsea pipeline crossings of other utilities

Crossing angle between utilities	at least 30° or, if possible, close to 90°
Clear distance between utilities	at least 0,3 m
To prevent damage, it is recommended to use hydraulic monitors for soil excavation in crossing area.	
Provision is made for laying designed pipelines underneath the existing pipelines by pulling them in prepared trench.	

11.2 EXAMPLES OF SUBSEA PIPELINE CROSSING CONFIGURATIONS

In regions with active development of underwater fields including the infrastructure development of a subsea pipeline system for various purposes (e.g. the North Sea, the Gulf of Mexico, etc.), crossing between the subsea pipeline routes cannot be avoided. The programs for decommissioning of offshore fields in such regions specify the structural solutions for the infrastructure development of the fields and provide certain crossing methods of underwater utilities [1], [2].

Examples of subsea pipeline crossing configurations depending on a depth of pipeline are specified in Figs. 11.2-1 and 11.2-2. Various options for a change in the configuration of pipelines are considered with the possibility of dismantling each of the crossing pipelines is taken into account, e.g. for disposal (the so-called pipeline sections of 3rd category — pipelines planned for decommissioning according to DNVGL-RP-F107).

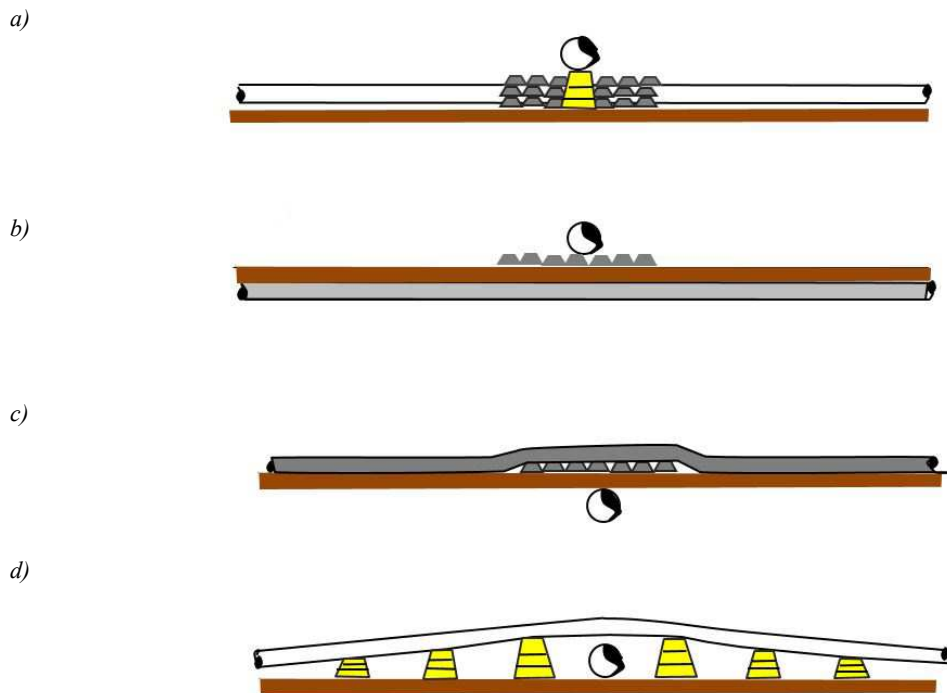

Fig. 11.2-1 Examples of subsea pipeline crossing configurations [1]:

- a* — non-buried pipeline crosses non-buried pipeline of 3rd category — dismantling (burial) is not possible;
- b* — non-buried pipeline crosses pipeline of 3rd category — with dismantling of 3rd category objects;
- c* — crossing of buried pipeline by 3rd category pipeline;
- d* — crossing by 3rd category pipeline of operating non-buried pipeline.

Crossings are usually constructed using flexible concrete mats, grout bags or special-purpose cast concrete structures. There shall be a minimum clearance between two pipelines at a crossing of 300 mm, and a concrete mat shall provide the required clearance and protection between the two pipes. The selection of other materials used for crossing construction depend on the required height of the pipeline crossing. For crossing of large diameter pipelines, special-purpose concrete structures are made.

Crossing of pipelines in temporarily inundated (flooded) areas or wetlands is allowed according to the provisions of the relevant normative documents [11]. A typical option of crossing in saturated wetland areas with segregation of topsoil (which may be characteristic of the landfall sections of subsea pipeline) is specified in Fig. 11.2-3. Construction equipment operating on wetland area is limited by operation period, technological overall dimensions required for trenching, manufacturing and laying of pipelines, backfilling of trench and time to restore the topsoil.

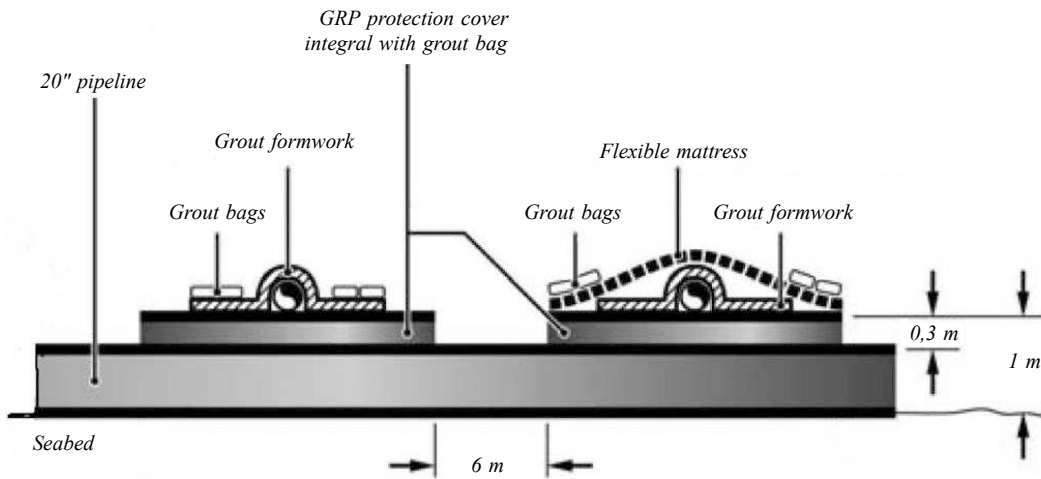

Fig. 11.2-2 Examples of structural solutions for subsea pipeline crossings [2]

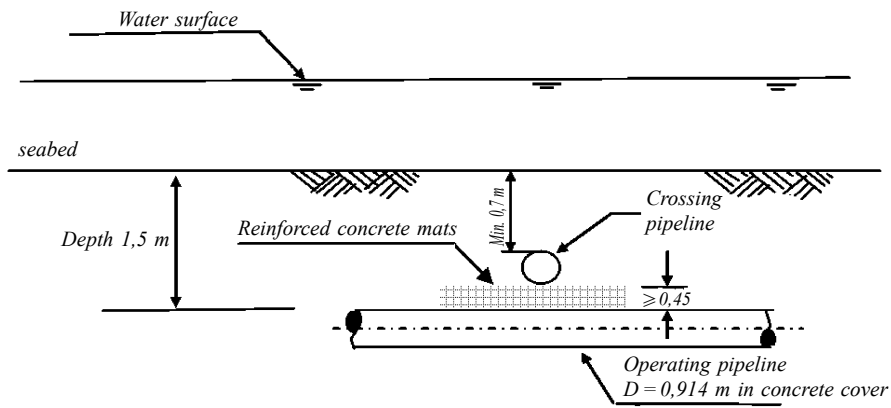

Fig. 11.2-3 Crossing of pipelines in flooded soil or wetland area

In areas where machines (mechanisms) are driven in water-saturated land or wetland to access the pipeline, the surface layer of soil shall be strong enough to construct temporary transport and installation routes. Diagram for laying the pipeline in such conditions is specified in Fig. 11.2-4 [4].

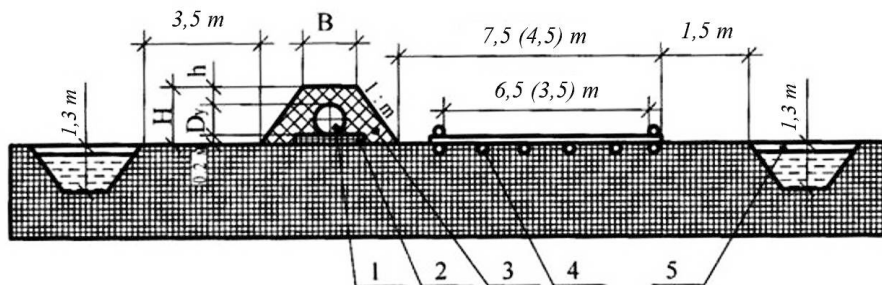

Fig. 11.2-4 Diagram of pipeline laying on surface of flooded soil or marshland:
 1 — pipeline; 2 — peat or brush matting; 3 — crowning of sand soil or peat; 4 — plank road; 5 — gutter trench

REFERENCES

1. Decommissioning of Pipelines in the North sea region/Association Limited, trading as Oil & Gas UK, Oil & Gas UK (Aberdeen), 2013.
2. DON-BP-001 Don Field Decommissioning Programme, BP, 2011.
3. DNVGL-RP-F116 Integrity management of submarine pipeline systems.
4. SP 36.13330.2012 Trunk pipelines. Revised edition of SNiP 2.05.06-85*.
5. SP 86.13330.2012 Trunk pipelines. Revised edition of SNiP III-42-80*.
6. GOST R 54382-2011 Oil and gas industry. Submarine pipeline systems. General requirements.
7. GOST R ISO 13623:2009 Petroleum and Natural Gas Industries. Pipeline Transportation Systems.
8. SP 115.13330.2016 Geophysics of Hazard Natural Processes. Revised edition of SNiP 22-01-95.
9. GOST 25100-2011 Soils. Classification.
10. SP 25.13330.2012 Soil bases and foundations on permafrost soils.
11. SNiP III-42-80 * Trunk pipelines (Section 9 "Laying of pipelines in special natural conditions").
12. DNVGL-ST-F101 Submarine Pipeline Systems, 2017.
13. ASME B31.4-2016 Pipeline Transportation Systems for Liquids and Slurries.
14. BS 8010-3:1993 Pipelines subsea: Design, Construction and Installation.
15. ABS Guide for Building and Classing Subsea Pipeline Systems, 2006 (Updated in February 2014).
16. Construction and Classification of Submarine Pipelines, Lloyd's Register, 2008.

12 REPAIR OF SUBSEA PIPELINES

Since the service life of the existing subsea pipeline systems in the Russian Federation increases, the issue of repairing subsea pipelines is becoming increasingly relevant in terms of improving the regulatory and technical framework and the development of methods and technology to carry out repair work at such facilities. The relevant normative base shall be improved in two directions:

.1 technical requirements for the implementation of the full range of possible repair work for subsea pipelines;

.2 standardization of the technical condition of subsea pipeline for the following purposes:

ranking the technical condition levels of pipeline depending on defect rate and forecast of pipeline service life with a defect of any given type;

selection of standard repair works that corresponds to the identified technical condition of the pipeline and standard defects;

planning of repair and diagnostic work, depending on the established level of technical condition for the purchase of equipment and materials, selection of contractors, etc.

Thus, the problem of repair and maintenance of subsea pipelines taking into account the above provisions is the key one to provide the uninterrupted functioning of the pipeline system with the required operating parameters throughout the design life. This integrated approach (pipeline integrity management) in accordance with ISO 19345-2 [14] is specified in Fig. 12.1.

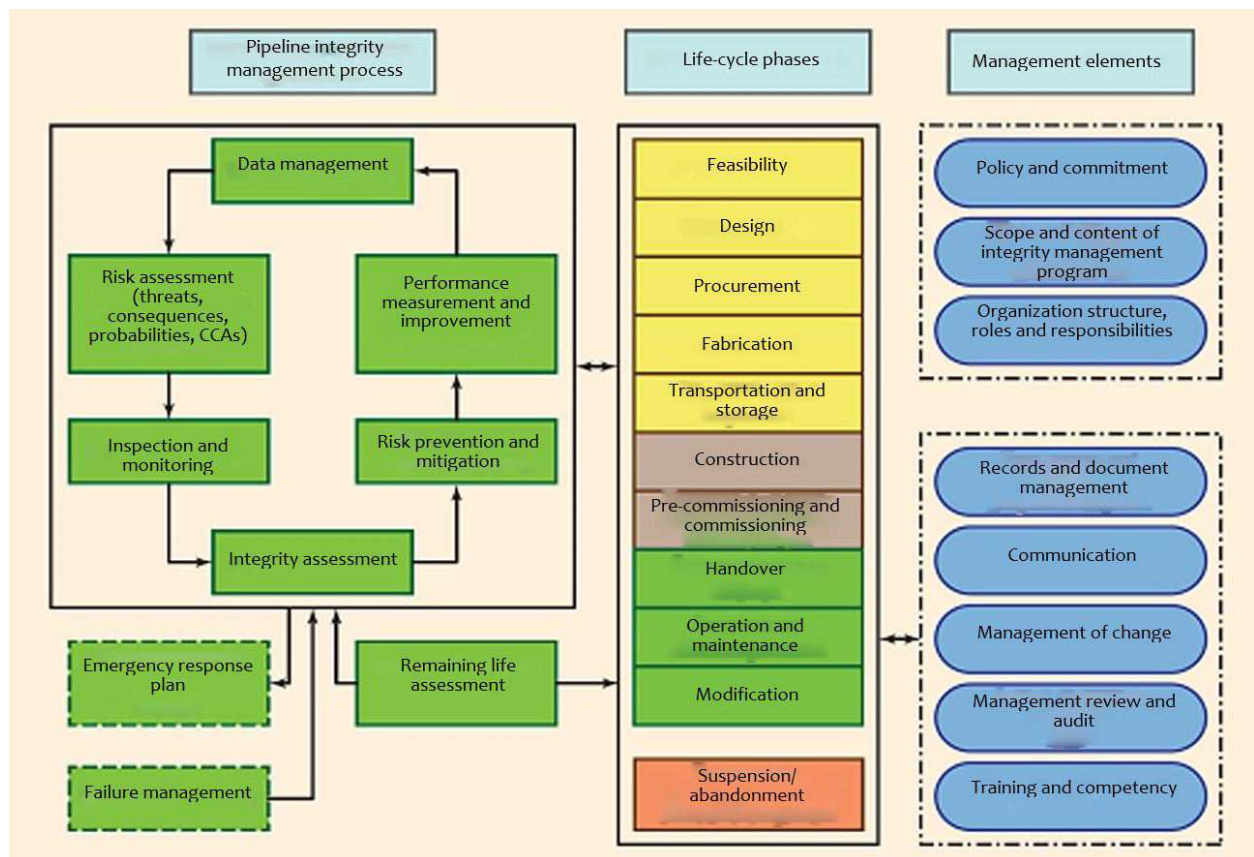

Fig. 12.1 Subsea pipeline integrity management program structure in accordance with ISO 19345-2

An even more comprehensive similar approach is implemented in the DNV GL practical activities and normative base (e.g. DNV-RP-F116 [16] and DNVGL-RP-F113 [15]) as well as in numerous implemented technologies and devices for repairs including those without involvement of divers ("diverless") for deep-sea underwater facilities (refer to 12.2 and 12.3).

12.1 RESTORATION OF DESIGN (OR SAFE) POSITION OF PIPELINE ON/IN SEABED SOIL INCLUDING FREE SPANS OF UNACCEPTABLE LENGTH

Restoration of the design (or safe) position of the pipeline on/in the seabed soil including free spans of unacceptable length, as well as construction of pre-excavated trenches and burial of subsea pipeline implies the use of various types of specialized watercraft and equipment for underwater excavation works (e.g. the Saipem S.p.A. system for burial and backfilling of subsea pipeline — refer to 7.6). However, as the experience of repair and restoration work on underwater pipeline systems in the Russian Federation (both at underwater crossings through water barriers and on subsea pipelines) shows, such works are mainly carried out with involvement of divers and mechanical aids for underwater technical works. This is primarily due to the fact that these defects arise basically as a result of the effects of waves and currents in the contiguous zone or rivers, where due to the small depths, it is possible to use diving equipment.

The elimination of pipeline saggings is carried out by filling washouts (voids) under the pipelines with stone, crushed rock and/or by laying gabions, flexible concrete mats, bags filled with sand and grout bags, as well as by hydraulic deposition of seabed soil. Stone, crushed rock or gabions/mats are delivered to the place of ramming using barges, while in the practice of the Russian contractors, as a rule, divers and floating cranes are used to work with gabions, mats and grout bags.

Typical diagram to eliminate saggings and/or washouts (stripping) of subsea pipelines when using bags with grout bags is specified in Fig. 12.1-1 and when using gabions or flexible concrete mats — in Fig. 12.1-2 [12].

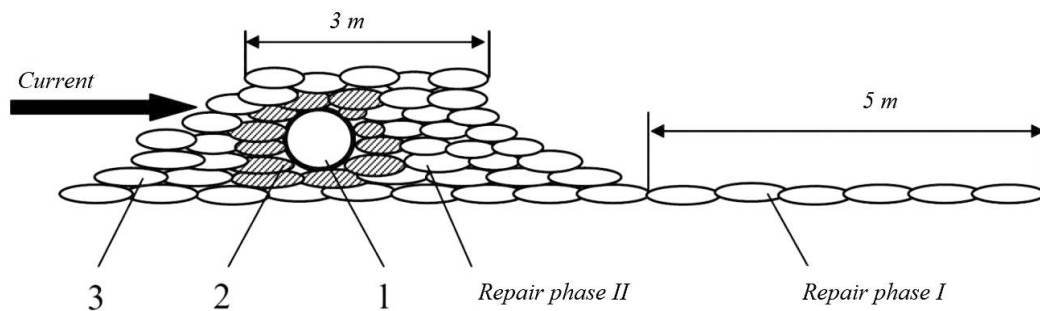

Fig. 12.1-1 Diagram of repair of stripped and sagging subsea pipeline areas using bags with sand-cement mixture:
 1 — pipeline; 2 — sand bags; 3 — grout bags

A slope of the front (in the direction of current or wave action) surface of masonry grout bags shall be 1:1, a slope of the back surface — 1:2.

For deep-water pipeline systems where involvement of divers for underwater excavation is not possible, similar pipeline defects are eliminated by using special-purpose equipment (refer to Fig. 12.1-3).

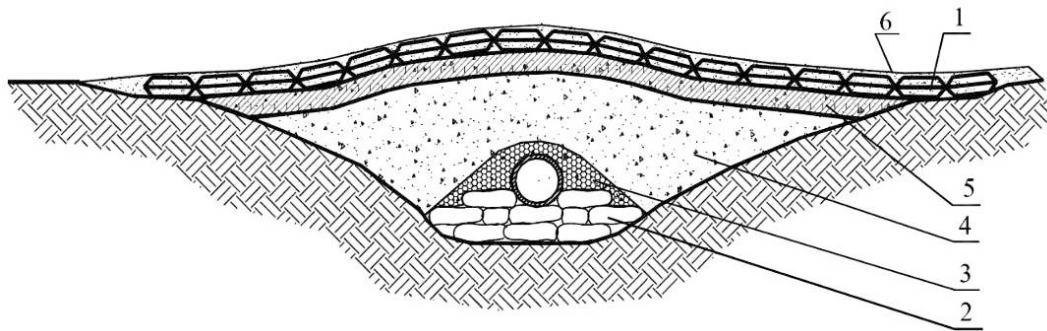

Fig. 12.1-2 Washout repair diagram using flexible concrete mats:
 1 — element of flexible concrete mat; 2 — sand bags or grout bags; 3 — soft soil (sand); 4 — filled soil;
 5 — crushed stone; 6 — sand



Fig. 12.1-3 Ramming of subsea pipeline in deep water area

12.2 REPAIR SYSTEMS OF NORD STREAM AG AND SAIPEM S.P.A.

12.2.1 Repair system of Nord Stream AG.

The Nord Stream subsea gas pipeline is a unique subsea transportation system for the Russian Federation both in terms of the natural gas transport parameters and in terms of the maintenance management.

During the construction of the pipeline system, Nord Stream AG made the detailed risk assessments for the design, construction and operation phases taking into account the following factors:

- exact route of the pipeline;
- characteristics of the main construction materials of the pipeline;
- seabed morphology;
- number and size of ships crossing over the pipeline;
- size and type of anchor used by a full range of ships that pass through the Baltic;
- size and type of fishing equipment used that may come into contact with the pipeline;
- conclusions and recommendations of studies conducted on many other offshore pipelines operating in the North Sea.

Thus, scenarios of incidents for which the so-called "Nord Stream pipeline repair strategy" was developed depending on the development of a particular incident and/or accident (Nord Stream Offshore Pipeline Repair Strategy) were identified (refer to Table 12.2.1).

Table 12.2.1

Levels of repair (maintenance) of Nord Stream subsea gas pipeline

TYPE OF SERVICE	REFERENCE DESCRIPTION
TYPE 1	FIRST REACTION + DAMAGE ASSESSMENT External Inspection
TYPE 2	MAINTENANCE / REMEDIAL WORKS e.g. rock placement for stabilisation; free span correction; pipeline protection; anode replacement...other
TYPE 3	LOCAL Damage Repair Externally fitted 48" dia. Repair Clamp
TYPE 4	SHORT Damage Repair Section replacement up to 2 pipe joints ~24m
TYPE 5	LONG Damage Repair Section replacement - hundreds of metres to several kilometres

The maintenance levels of the Nord Stream subsea gas pipeline are in many respects identical to the concept of "technical condition". The types of repairs introduced by the Nord Stream Offshore Pipeline Repair Strategy (in addition to various kinds of diagnostic work):

- maintenance/remedial works (scheduled preventive) repair;
- local damage repair (using repair clamps);
- short damage repair (replacement up to 2 pipes);
- long damage repair (replacement of pipeline string over 100 m).

The specified types of repair shall be provided with an appropriate set of technical means for the implementation of repairs of different levels that are clearly regulated by the organizational and technological procedures and by the selection of a contractor for the performance of work.

As a main repair contractor for all types of repair work on the basis of an open tender process, Nord Stream AG has selected Saipem S.p.A., which will supervise repair work in the event of an incident that requires investigation and potential repair. In addition, Saipem S.p.A. developed the required organizational/technological procedures and identified the required equipment to restore, if repair is needed, the initial design parameters of the subsea gas pipeline.

Another significant element of the Nord Stream Pipeline Repair Strategy is the membership of Nord Stream AG to the Statoil administered Pipeline Repair and Subsea Intervention (PRSI) Pool. Through the membership, Nord Stream AG has access to a number of specialized services and equipment that are technically most suitable to perform underwater work on large-diameter pipes. The main technological system in the Nord Stream service support complex is the Hyperbaric Welding System which was already used during the offshore pipeline construction phase to complete with a series of Hyperbaric Weld Tie-in (HWTI) (refer to Fig. 12.2.1).

Technip and Deep Ocean are planned to participate as subcontractors in the specified works.

12.2.2 Repair system of Saipem S.p.A.

Remotely operated subsea pipeline repair system SiRCoS (Italian, Sistema Riparazione Condotte Sottomarine) has been developed for the Italian oil and gas company Eni. The repair system

allows performing works at very large depths, and may also be used in the process of subsea pipeline laying and operation (maintenance) [11].

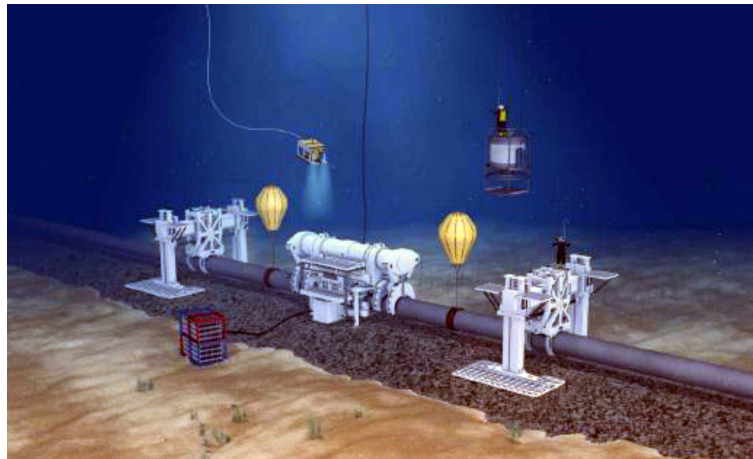

Fig. 12.2.1 Repair system of Nord Stream pipeline using Hyperbaric Welding System

SiRCoS is an integrated "diverless" system to repair the pipelines laid in mid-depth and deep water. The system allows to install a sleeve (clamp) on the local damage and replace a pipeline section in case of major damage.

SiRCoS has the following main operational specifications:

maximum depth of the repair work is 2200 m;

maximum seabed slope angle is 10° in transversal direction, 15° in longitudinal direction (30° for the repair clamp/repair sleeve);

pipeline diameter for the connection system is 0,46 — 1,22 m;

range of pipe wall thickness is 17,4 — 41,0 mm;

pipe material: steel grades X60 — X70;

removal of corrosion-protection and concrete coating of pipes up to 100 mm thick.

A set of the required components to restore the operability of the pipeline includes:

repair sleeve (clamp) to correct minor local damage (leaks and deformations);

spool used to replace pipeline sections;

end connectors.

One spool and two end connectors are the minimum set installed on the pipeline in case of major damage that requires that the pipeline be cut using a Remotely Operated Vehicle (ROV) with an attached hydraulic power unit.

Connection between the connector and the pipe end is provided by press-fitting, while the press-fitting device using sea water as a working medium creates the sufficient pressure inside the pipeline body to crimp it in the connector. Thus, the pipe wall is deformed plastically on the internal surface of the end connector, and the connector itself is subjected to elastic expansion (refer to Fig. 12.2.2, *f*), thus creating a reliable tight connection.

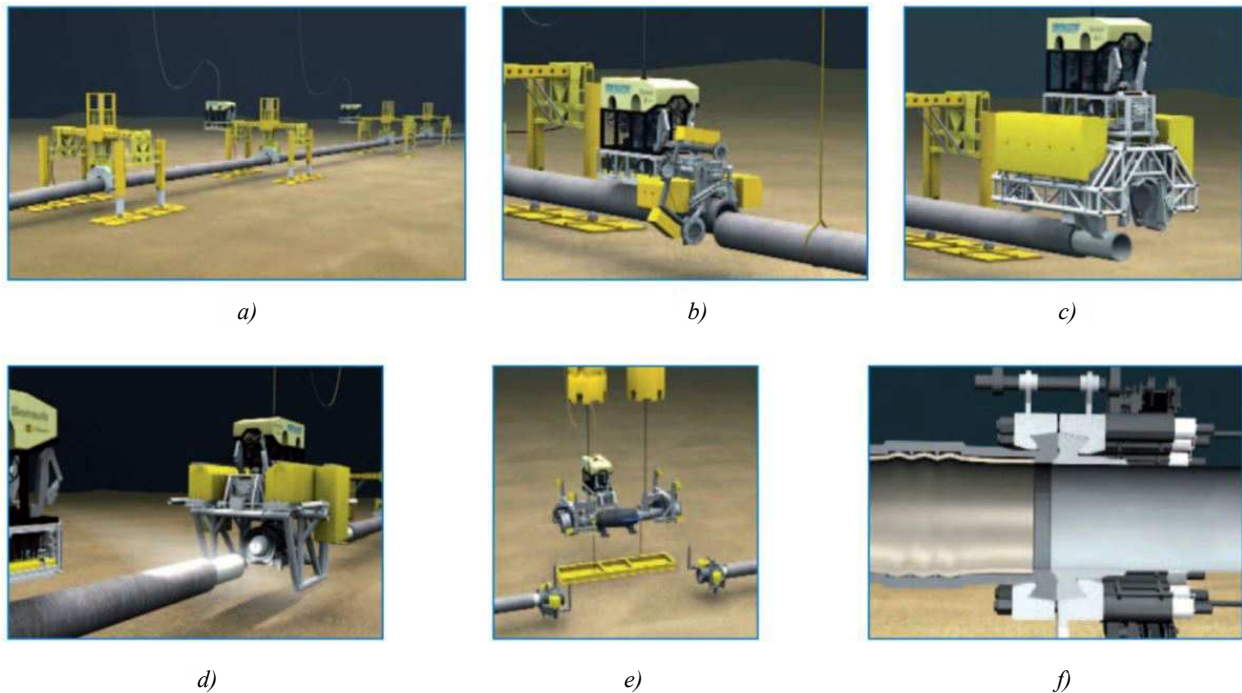

Fig. 12.2.2 Replacement sequence of subsea pipeline section using pipeline repair system SiRCoS:
a — lifting of pipeline sections by means of four *H*-shaped supports;
b — cutting of and removing of the damaged section of the pipeline;
c — removal of the concrete weight coating; *d* — installation of end connectors;
e — positioning and mounting of a spool piece using the mounting module; *f* — connection

12.3 METHODS AND TECHNOLOGIES APPLIED FOR REPAIR OF INDIVIDUAL DEFECTS, GROUPS OF DEFECTS, DEFECTIVE SECTIONS (AREAS) OF STEEL SUBSEA PIPELINES

12.3.1 The methods and technologies of repair of subsea pipeline systems that are currently used in offshore fields of the Russian Federation, which may be applied by national contractors are provided in Fig. 12.3-1.

As compared to the examples of repair systems or special devices for subsea pipeline repair (refer to 12.2) including deep-water ones, the methods and technologies specified in Fig. 12.3-1 correspond to the parameters of the currently developed Russian offshore hydrocarbon fields and the technical potential of national contractors.

Some repair devices approved by RS for performing repair work on subsea pipelines are specified in Fig. 12.3-2. All the devices specified are used in practice in the process of repairing subsea pipeline systems. In particular, the following is applied:

- composite reinforcement sleeves SMART LOCK (UKMT) (refer to Fig. 12.3-2, *a*);
- reinforcing sleeve-protector with concrete banding (UBMT) (refer to Fig. 12.3-2, *b*);
- repair device for steel pipelines of various purposes (URST-M) (refer to Fig. 12.3-2, *c*);
- repair device for curvilinear section of steel pipelines of various purposes (URST-K) (refer to Fig. 12.3-2, *d*);
- insulating composite clamps (protectors) SMART WRAP (IKMT) (refer to Fig. 12.3-2, *e*).

The repair devices specified above have been approved by industrial safety expert reviews and have Type Approval Certificates (CTO) issued by RS.

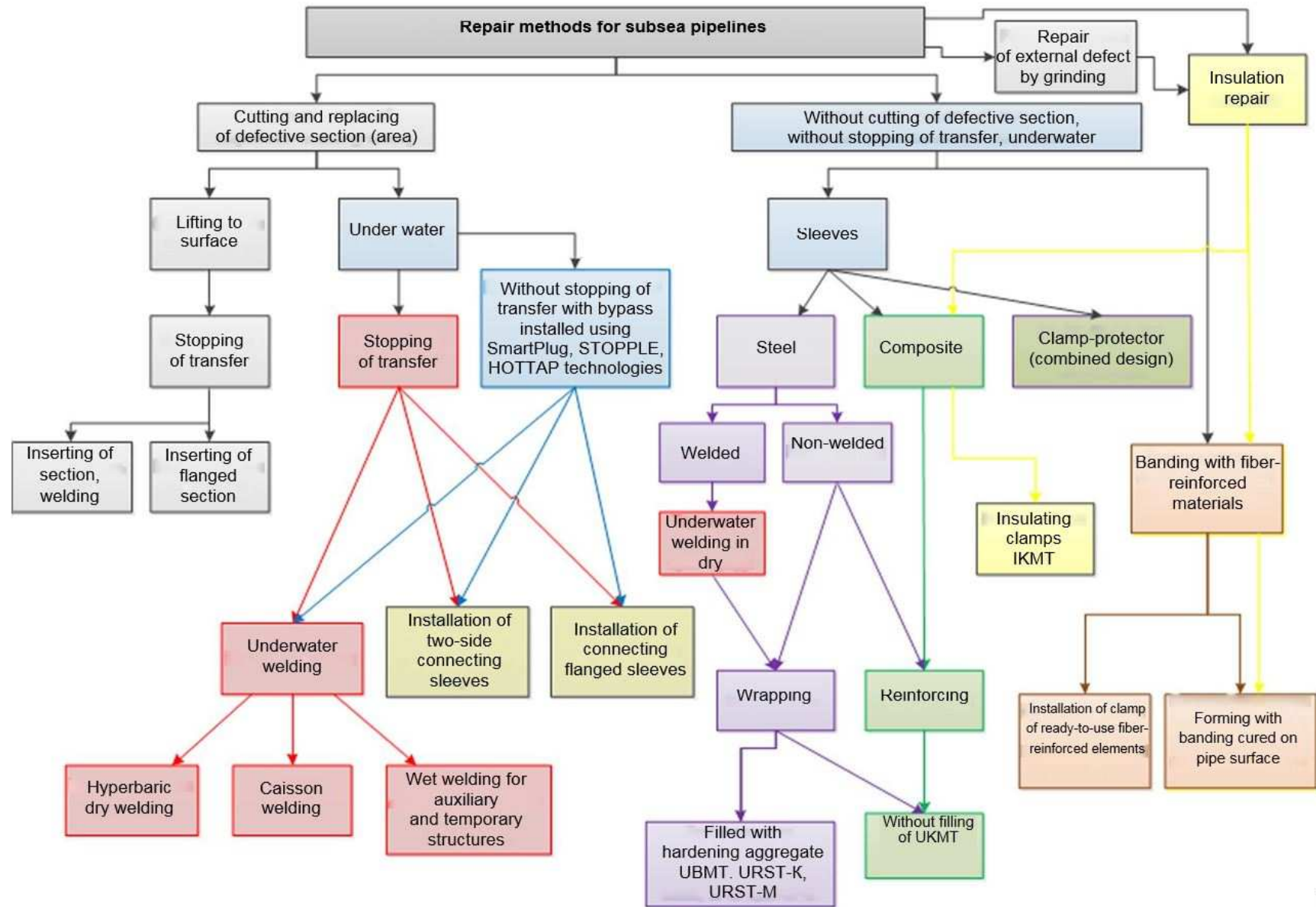

Fig. 12.3-1 Methods and technologies for repair of subsea pipelines in offshore hydrocarbon fields in the territory of the Russian Federation

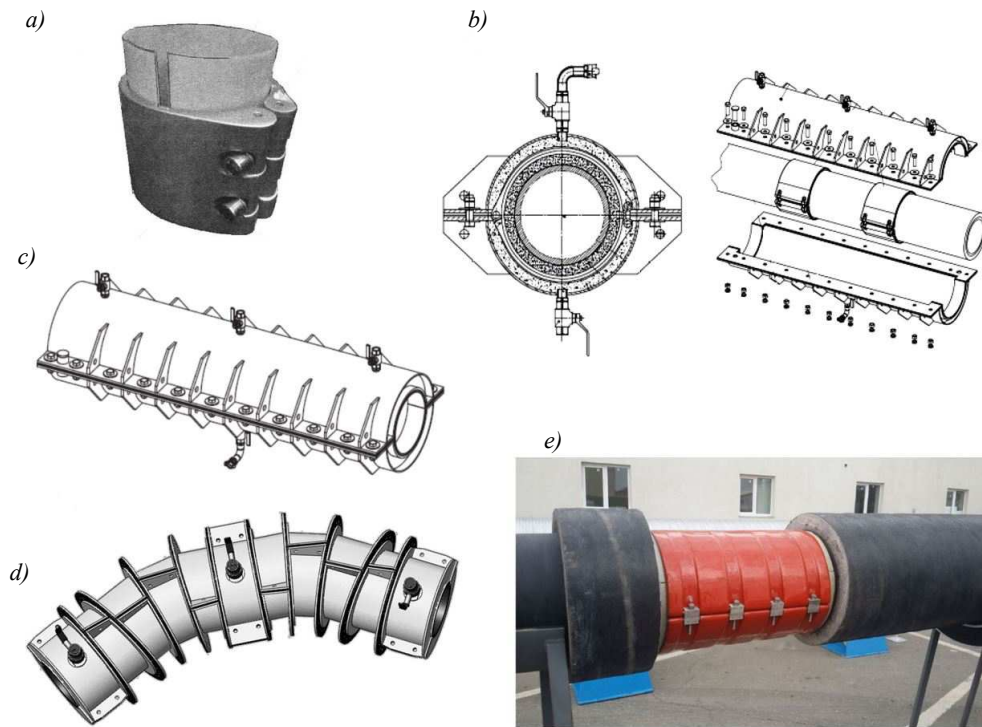

Fig. 12.3-2 Devices for repair of subsea pipelines approved by the Register

Since 2008 in the national practice of repair at underwater crossings of main gas pipelines and subsea pipelines, an Offshore Pipe Repair Platform of project 91030 constructed at ZNT Yard has been used with the following main particulars:

length overall, in m	42,0
breadth, in m	16,7
freeboard depth, in m	4,3
draught, in m	2,6
operating endurance, in days	15
displacement w/100 % stores, in t	1426
power plant capacity, in kW	3 × 150
crew, in pers	11

The platform is of four-leg jack-up type designed to protect against the effect of water, wind and waves on the hull during repair work (similar to self-elevating mobile offshore drilling units) (refer to Fig. 12.3-3). The platform height above the water level is up to 2,0 m. A Welding Assembly Caisson Chamber (WAC) is designed to repair damaged sections of subsea pipelines of 500 — 1420 mm in diameter at depths up to 24 m according to the Cofferdam Welding procedure. The WAC is equipped with special systems that provide its tightening on the pipeline and self-draining. When in operational state, the WAC communicates with the platform by means of an articulated multi-section passage trunk.

The WAC operation is provided by the following devices:

- lowering and lifting;
- on-ground supporting;
- WAC-to-pipeline positioning;
- WAC-to-pipeline connection;
- attachment and sealing of the WAC bottom part;
- drainage/filling system;
- in-WAC pipeline locking.

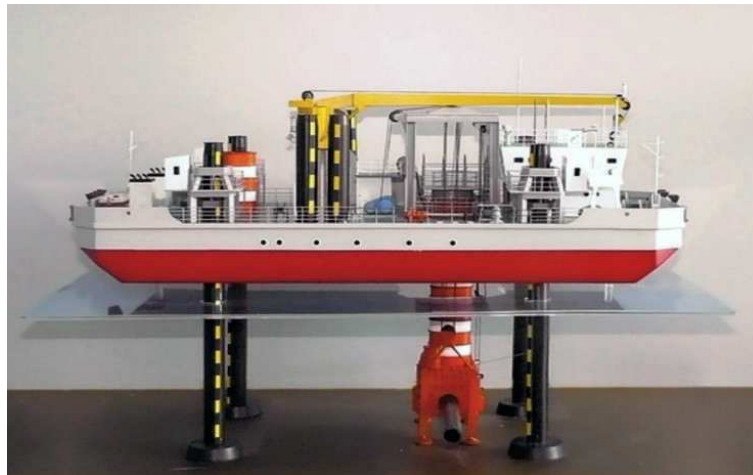

Fig. 12.3-3 Offshore Pipe Repair Platform (project 91030)

When performing repair work, WAC is equipped with special high-performance gas-cutting and electrical welding equipment. For mounting of individual sections during assembly of the passage trunk, installation of supports of the lowering and lifting device and other operations, a crane with a capacity of 16 t and 22-m boom reach is installed on the platform deck. For accurate positioning over the pipeline, the platform is equipped thrusters and a satellite pointing system. Provision is made on the platform for a complete set of diving outfit.

12.3.2 Maintenance of subsea pipeline systems outside the territory of the Russian Federation is performed by the following main developers and suppliers of special-purpose equipment for the repair of subsea pipelines: T.D. Williamson, Inc. (USA), Acer Solution ASA (Norway), Cameron International Corporation (USA), Oil States Hydro Tech, Inc., Subsea 7 S.A., Hydratight, Ltd. (United Kingdom), Oceaneereng International, Inc., Furmanite Corporation (USA), etc.

The following shall be noted regarding the equipment supplied by the companies specified.

Currently, T.D. Williamson, Inc. is the world leader in the production of tetherless and remotely controlled Smart Plug tools that are moved inside pipelines. Such tools are designed to cut off the pipeline sections to be repaired or serviced including curvilinear ones with the bend radius up to 1,5x pipeline diameters and to maintain the working pressure of transported medium (up to 21 MPa) in the pipeline system, including crude oil, gas, gas condensate, glycol, oil products, etc. (refer to Fig. 12.3-4).

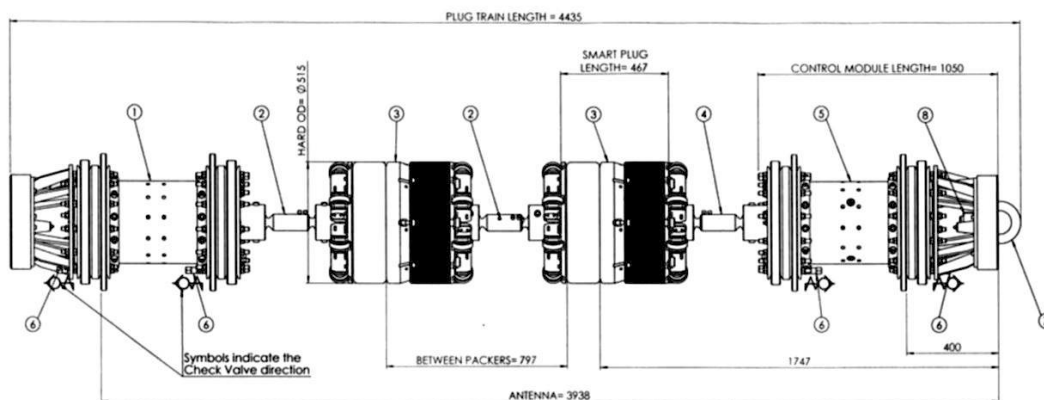

Fig. 12.3-4 General view and layout of 2 × 24" SmartPlug tool:

- 1 — control module; 2 — ball joint to flange; 3 — plug module with packer; 4 — ball joint; 5 — control module;
- 6 — check valve; 7 — eyebolt; 8 — eyebolt nut

A 24-inch (610 mm) 2 × 24" controlled SmartPlug tool is used for maintenance and repair of the Blue Stream subsea gas pipeline across the Black Sea from the Russian Federation to Turkey: replacement of shut-off gate valves at the Beregovaya compressor station in the Russian Federation without termination the process of gas transport at a pressure of 7,0 MPa. The set of supplied devices, as a rule, consists of the following:

two controlled SmartPlug tools, each of which is a train that includes two gate valves (SmartPlug) and two control modules (Pigging — Control Module);

PC-based equipment to control the operation, receiving and transmitting antennas for remote control of the gate valve operation, which allows controlling the gate valve at a distance up to 240 km with the pipeline buried into the seabed soil up to 9,0 m.

In some cases, e.g. were the product transfer through the pipeline cannot be stopped, a bypass line shall be installed that bypasses the repaired pipeline section; the installation technology of the bypass line was also developed by T.D. Williamson, Inc., and the devices may be installed by ROV without involvement of divers (refer to Fig. 12.3-5).

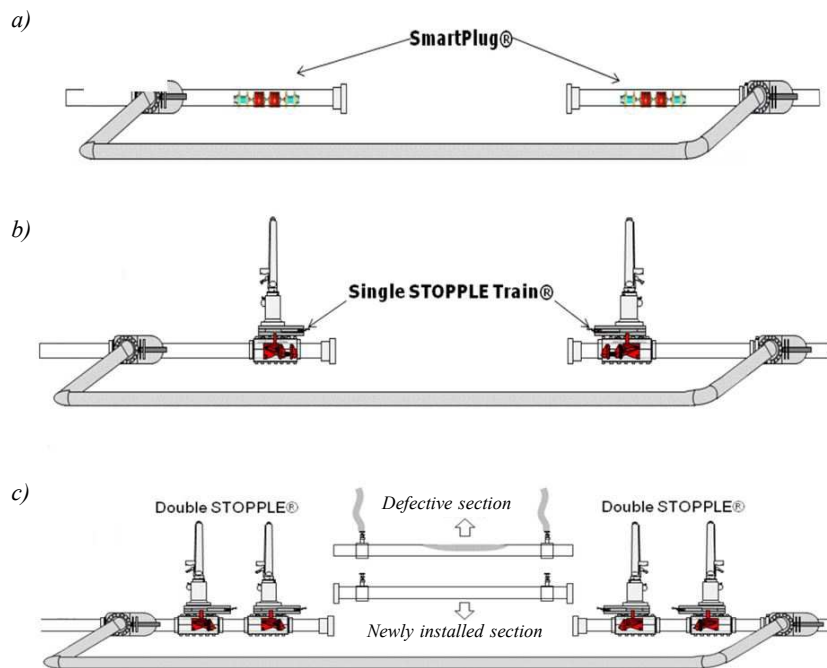

Fig. 12.3-5 Construction of bypass line using SmartPlug shut-off devices (a), Hot Tapping tie-in technology using devices Single STOPPLE Train (b) and Double STOPPLE Train (c)

One of the main means of repair of subsea pipelines are steel crimping sleeves, which are installed on the pipeline without welding (refer to Table 12.2.1). Repair sleeves are a steel structure in the form of a hollow cylinder divided lengthwise in two equal halves with double sealing elements, a set of cross and longitudinal fasteners, de-elongation rings and an axial displacement prevention device (refer to Fig. 12.3-6) [5]. The double elastomer seal makes it possible to carry out tests for strength and tightness after mounting the sleeve in a cavity between the seals of the sleeve itself without increasing the pressure in the main pipeline, which significantly decreases and simplifies the repair procedure and reduces its cost.

The sleeves are manufactured in various lengths for pipelines 51 mm to 1420 mm in diameter. For the sleeves of simple design, the sealing of the damaged pipeline section is provided by crimping the seals directly by the sleeve body during its installation. Additional structures may also be considered to provide the required crimping of the seals when sealing the damaged section of subsea pipeline. A variety of curved sleeves is manufactured for the repair of hot bends in the pipeline.

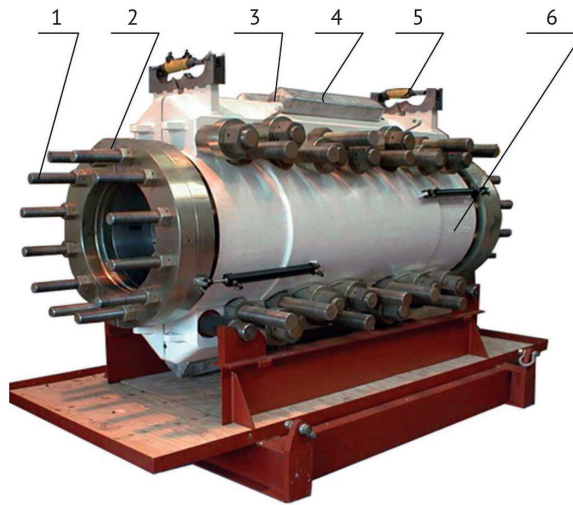

Fig. 12.3-6 Repair non-welded sleeve:
 1 — threaded stud of axial fastening element; 2 — device to prevent axial displacement;
 3 — lifting lug; 4 — galvanic anode; 5 — hydraulic jack; 6 — clamp body

When repairing subsea pipelines at great depths (more than 120 m), only the work class ROVs are used to install the sleeves, while the fastening elements of the sleeves are designed for operation of the ROV manipulators.

12.4 TECHNICAL DIAGNOSTICS OF PIPELINES

12.4.1 In-line inspection (ILI) is the most informative methods for identifying and measurements of defects both in terms of scope and quality of the data obtained. In some cases, ILI is the only possible alternative method to identify defects.

The ILI method provides the following:

possibility of examining the pipeline geometry that allows identifying dents, kinks, corrugations, ovality, as well as various geometric anomalies and deformations that cause stresses including those in the buried sections of the pipeline;

possibility of examining the three-dimensional position of the pipeline that allows to detect the pipeline displacement and the bending deformations (occurring due to displacement of the pipeline relative to its original position) by comparing the three-dimensional data of several repeated inspection passes.

Magnetic or ultrasonic non-destructive testing method is implemented in most inspection pigs.

12.4.2 The ILI technology with registration of magnetic flux dispersion (MFL — Magnetic Flux Leakage).

The magnetic technology allows monitoring any transported medium at velocity of 0,5 m/s to 5 m/s and exceeding this value. There are the following magnetic technology types:

.1 with magnetization of the pipe wall in the longitudinal direction (CDP — Corrosion Detection Pig). This technology allows identifying and measuring internal and external metal loss anomalies such as corrosion, girth weld anomalies and factory anomalies;

When applying this technology, the possibility to detect anomalies in the longitudinal welds, longitudinally oriented anomalies (stress-corrosion cracks), indirect measurement of actual thickness of pipe wall is reduced;

.2 with magnetization of the pipe wall in the transverse direction (AFD/TFI — Axial Flow Detection/Transverse Field Inspection). This technology allows identifying and measuring narrow

longitudinally-oriented anomalies such as pipe wall irregularities (e.g. scratches, marks, crack-like anomalies and rill corrosion).

When applying this technology, the possibility to detect anomalies in transverse welds, transversely-oriented anomalies, indirect measurement of actual thickness of pipe wall.

12.4.3 ILI ultrasonic technologies (UT — Ultrasonic Test).

Ultrasonic technology UT-WM (Wall Measurement) allows identifying and measuring internal and external metal loss, delaminations, inclusions, scratches, notches, scores and dents, as well as their combinations, to perform direct accurate measurements of residual thickness of pipe wall.

UT-CD technology (crack detection) is used to detect longitudinal and transverse cracks in pipeline walls including in longitudinal and transverse welds.

The inspection pig pass speed when applying WM/CD technologies is 0,5 m/s — 3,0 m/s.

When applying this technology, pipeline examination may be performed in liquid medium only.

12.4.4 Electromagnetic-acoustic transducer method (EMAT).

The EMAT method is based on contact-free generation using the electromagnetic field and receiving sound waves, and allows detecting delamination areas, damage to the insulation coating and their sizes, detecting and determining with high accuracy a size of cracks, such as stress-corrosion cracks, longitudinal fatigue cracks, hook-shaped cracks, cracks on the external boundary of the weld, in the base metal of the pipe, in the weld area for any medium transported.

The EMAT method is not efficient when applied to pipes with the wall thickness of more than 20 mm. Inspection pigs exist for pipes with a diameter of 508 mm (20") and more. The method application is associated with expensive equipment that makes the technology available to a limited number of enterprises.

12.4.5 Eddy current ILI technology (IEC — Inspection Eddy Current).

The technology allows accurately identifying and measuring corrosion damage to the surface layer of the internal surface of the inspected pipe regardless of its wall thickness. Mainly used to detect defects in the internal coating of pipelines. The technology is used for inspection of pipelines without creating liquid plugs. Due to the electromagnetic nature of this technology, the accuracy of the inspection results is not affected by the presence of anti-friction coating, moderate scale or contamination.

The technology is not efficient when identifying defects inside the pipe wall, external defects, defects in welded butt joints.

Efficiency analysis of ILI technologies for identification and measurement of various types of defects is provided in Table 13.4. It shall be noted that modern inspection pigs provide the relevant control quality at a speed of 0,1 to 10 m/s. If necessary, an inspection pig is additionally equipped with a device (regulator) of its own speed relative to the flow rate, which is mainly used at high flow rates in gas pipelines.

According to Federal Law of the Russian Federation No. 102-FZ of June 26, 2008 "On Ensuring the Uniformity of Measurements" and Order of the Ministry of Industry and Trade of the Russian Federation No. 971 of June 25, 2013 "On Approval of Administrative Regulations for Providing by the Federal Agency for Technical Regulation and Metrology of State Service on Classifying of Technical Means as Measuring Instruments", inspection pigs are classified as measuring instruments and subject to metrological testing in accordance with the requirements of the Federal Agency on Technical Regulation and Metrology (Rosstandart).

REFERENCES

1. Borodavkin P.P., Berezin V.L., Shadrin O.B. Submarine pipelines. Moscow, Nedra, 1979.
2. Zabela K.A. Elimination of accidents and repair of underwater pipelines. Moscow, Nedra, 1986.
3. Borodavkin P.P. Offshore oil and gas facilities. Parts 1 and 2. Moscow, Nedra, 2006.
4. SNiP 2.05.06-85 Trunk pipelines, 1985.
5. Petrenko V., Novikov A., Kurilets S. Repair of offshore pipelines. Offshore Russia, 2017.
6. GOST R 54382-2011 "Oil and gas industry. Submarine pipeline systems. General requirements".
7. GOST R 55999-2014 "In-line inspection of gas pipelines. General requirements".
8. R Gazprom 2-2.3-594-2011 "Criteria for assessing of technical condition and recommendations for maintenance of underwater crossings of JSC Gazprom pipelines.
9. RD 23.040.00-KTN-090-07 "Classification of defects and repair methods for defects and defective sections of existing main oil pipelines".
10. RD 31.74.08-85 "Technical instructions for marine dredging operations".
11. Fabbri S., Cavallini R., Giolo R., Spinelli C. SIRCoS: pipeline repair beyond diver depth. Moscow, Gazprom VNIIGAZ LLC, 2015.
12. Catalogue of typical technological schemes for repair of underwater crossings of main oil pipelines. Ufa: VNIISPT Oil, 1985.
13. R Gazprom 2-2.3-703-2013. Technological schemes of repair of underwater crossings.
14. ISO 19345-2 "Petroleum and natural gas industry — Pipeline transportation systems — Pipeline integrity management specification — Part 2: Full-lifecycle integrity management for offshore pipeline".
15. DNV GL-RP-F113. Pipeline Subsea Repair.
16. DNV-RP-F116. Integrity Management of Submarine Pipeline Systems.

Table 12.4

Efficiency analysis of ILI technologies for identification and measurement of various types of defects

Metal loss defects	ILI technologies				
	MFL with longitudinal magnetization	MFL with transverse magnetization	UT	IEC	EMAT
Extensive corrosion	****	****	***	*** (внутренняя)	***
Pit corrosion	***	**	**	**	**
Longitudinal groove	**	***	**	*	*
Lateral groove	***	*	***	**	**
Narrow longitudinal corrosion	*	***	**	*	*
Girth weld anomaly	***	—	— ** (CD)	—	—
Longitudinal weld defect	*	***	*	—	—
Dents with metal loss	***	***	**	**	**
Metal objects in close up	***	**	—	—	—
Lamination and other defects within a pipe body	**	**	****	—	*
Analysis					
Defect identification	***	***	***	**	**
Length determination	***	***	***	**	***
Depth Determination	**	**	***	*	**
Working medium					
Gas	****	****	—	***	***
Liquid or multiphase	****	****	****	***	***
Inspection pigs pass speed					
Increased speed (more than 5 m/s)	***	***	**	**	*
<p> — not applied * — inefficient; ** — low efficiency; *** — efficient; **** — best solution. </p>					

Российский морской регистр судоходства

**Рекомендации по проектированию, постройке и эксплуатации
морских подводных трубопроводов**

Russian Maritime Register of Shipping

**Recommendations for Design, Construction
and Operation of Subsea Pipelines**

The edition is prepared
by Russian Maritime Register of Shipping
8, Dvortsovaya Naberezhnaya,
191186, St. Petersburg,
Russian Federation
www.rs-class.org/en/