

GUIDELINES

ON THE CONDITION ASSESSMENT PROGRAM (CAP)

ND No. 2-039901-006-E



St. Petersburg

GUIDELINES ON THE CONDITION ASSESSMENT PROGRAM (CAP)

The Guidelines on the Condition Assessment Program (CAP) of Russian Maritime Register of Shipping (RS, the Register) have been approved in accordance with the established approval procedure and come into force on 15 April 2025.

The present version is based on the version dated 12 September 2023 taking into account the amendments and additions developed immediately before publication (refer to the Revision History).

REVISION HISTORY¹

For this version, there are no amendments to be included in the Revision History.

¹ With the exception of amendments and additions introduced by Rule Change Notices (RCN), as well as of misprints and omissions.

1 GENERAL PROVISIONS

The Guidelines on the Condition Assessment Program (CAP) (hereinafter referred to as "the Guidelines") have been developed on the basis of the Register's experience in the CAP implementation, considering the requirements of oil companies which are direct consumers of the Register CAP-specific services.

1.1 APPLICATION

The Guidelines establish the procedure and scope of CAP as well as the rating criteria.

1.2 DEFINITIONS AND EXPLANATIONS

1.2.1 Definitions and explanations relating to general terminology of the RS normative documents are given in Part I "Classification" of the Rules for the Classification and Construction of Sea-Going Ships and Part I "General Regulations for Technical Supervision" of the Rules for Technical Supervision during Construction of Ships and Manufacture of Materials and Products for Ships.

1.2.2 For the purpose of these Guidelines the following definitions and explanations have been adopted.

Hot spots are the locations where fatigue cracking may occur due to the combined effect of nominal stress fluctuation and stress raising effects due to connection geometry and weld notches.

Close-up survey is a survey where the details of structural components are within the close visual inspection range of the attending surveyor, i.e. normally within reach of hand.

Overall survey is a survey intended to report on the overall conditions of the hull structure and determine the extent of additional close-up surveys.

1.3 ABBREVIATIONS

CAP — Condition Assessment Program.

ACS — another classification society.

RHO — RS Head Office.

CAP Certificate — Certificate of Condition Assessment Program (CAP) (Form 3.1.12).

2 LIST OF INFORMATION SUBMITTED BY THE CUSTOMER

2.1 The following information shall be submitted to enable the performance of the ship condition assessment program:

2.1.1 Name of item groups for Condition Assessment Program survey of a ship ("HULL", "MACHINERY, SYSTEMS").

2.1.2 Name, registry number, IMO number, port of registry, flag, type, date of build, gross tonnage, class notation.

2.1.3 Overall length, width, freeboard, summer draught, propulsion type.

2.1.4 Type of main machinery, total power.

2.1.5 Type and material of propeller shaft, propeller shaft liners, lubrication system of stern tube bearings, type of shaft to propeller connection.

2.1.6 Information on introduction of ship into propeller shaft/shafting condition monitoring (PCM/SCM) system, date of bringing the ship to PCM/SCM system (if any).

2.1.7 Information on planned date and place of ship submission (if any), details of agent in ship submission port.

2.1.8 General arrangement plan of the ship.

2.1.9 Ship Loading Manual and/or Stability Booklet.

2.1.10 Depending on the selected group of CAP items: drawings of hull, mechanical and electrical installations of the ship, diagrams of ship systems. The scope of information from hull drawings shall allow to perform calculations of hull structures regulated by this document. In particular, when performing fatigue life calculations, hull drawings shall contain hull framing connecting assemblies.

2.1.11 List of ship machinery, arrangements, systems, including cargo system.

2.1.12 Copy of Classification Certificate and other certificates, if any.

2.1.13 If applicable: reports, checklists, ACS-IACS member reports on condition of the hull, as minimum, last special and subsequent surveys of the ship.

2.1.14 Thickness measurement reports, repair reports prepared according to [Appendix 2](#), and other documents concerning actual technical condition of the ship hull for the 10-year operation period preceding the CAP execution.

2.1.15 Ship hull damage history for the entire service period of the ship.

2.1.16 Information on transported cargoes and operation areas for the last 3 years of ship service.

2.1.17 Planned maintenance system (PMS) documentation, if any, for ship's machinery and cargo system, including:

maintenance schedules;

documents confirming fulfillment of PMS operations and schedules;

documents demonstrating technical condition before and after maintenance;

documents with records on accidents, failures and emergencies, replacement and repair of CAP items.

2.1.18 Records of technical condition and/or worksheets for checking technical condition of machinery, or specially developed forms of records for the results of technical condition monitoring during maintenance. The documents submitted shall contain the results of surveys and measurements carried out during maintenance, as well as limit values of technical condition parameters (sizes, clearances, condition of surfaces, etc.) determined by the manufacturer or other recognized organization. Causes of failures, emergencies, replacements and repairs shall be specified.

2.1.19 Information on cathodic protection installation, instruction on renewal of anodes fitted on the ship's outer hull afloat.

2.1.20 Specification of cathodic protection and its installation diagram.

2.1.21 Copy of document confirming entering the ship into PCM/SCM system.

2.1.22 Copy of document confirming entering the ship into PMS system.

3 CONDITION ASSESSMENT PROGRAM (CAP)

3.1 GENERAL PROVISIONS

3.1.1 CAP is an additional procedure to classification procedure of the Register intended for assessment and analysis of actual condition of ship's hull structures, mechanical installation, machinery, arrangements, systems and electrical equipment. CAP is a tool for quality assessment of the ship and ship's elements, irrespective of age in accordance with the established rating system.

3.1.2 CAP may be carried out for the following groups of items:
ship's hull ("HULL" group);
mechanical installation, machinery, arrangements, systems, including cargo system and electrical equipment of the ship ("MACHINERY, SYSTEMS" group).

The items included in each group are given in [3.5.6](#) and [3.5.7](#).

3.1.3 CAP is carried out by the Register at the Request of a shipowner on a reimbursement basis for self-propelled sea-going oil tankers and oil bulk carriers, chemical tankers, gas carriers.

3.1.4 CAP results are used by insurance companies, cargo terminals, charterers and shipowners.

3.1.5 The objective of CAP is to determine actual condition of items listed in [3.5.6](#) and [3.5.7](#), and to assign the rating to the groups of ship's items in compliance with the applicable requirements of the Rules for the Classification and Construction of Sea-Going Ships and the Rules for Technical Supervision of Ships in Service¹.

3.1.6 Calculations of hull strength and fatigue life (if applicable) for compliance with CAP criteria are performed by RHO. The timeframe for calculations performance shall be agreed with the shipowner. The performance of the above calculations by third party organizations is not allowed.

3.1.7 The unified CAP rating scale is described in [3.2](#).

3.1.8 Within CAP the Register does not assess ship's characteristics having direct effect on the commercial results of ship's operation, such as speed, fuel rate of main engine, auxiliary machinery, etc.

3.1.9 Based on the CAP results, a CAP Certificate (Form 3.1.12) or a Letter of Conclusion is issued, as indicated in [3.8](#).

3.1.10 The CAP Certificate has no validity terms and reflects the ship condition on the date of survey completion.

¹ Hereinafter referred to as the Rules TSSS

3.2 CONDITION RATING SCALE

3.2.1 The actual condition of a ship or the ship's components and elements is assessed by the Register under the unified rating scale (rating system) between CAP1 and CAP4, where:

CAP1 is the maximum rating corresponding to "very good" actual condition of ship (or ship's components and elements);

CAP2 corresponds to "good" actual condition of ship (or ship's components and elements);

CAP3 corresponds to "satisfactory" actual condition of ship (or ship's components and elements);

CAP4 corresponds to "poor" actual condition of ship (or ship's components and elements).

3.2.2 CAP rating system for the "HULL" group is based on the assumption that the components selected for assessment are sufficient for evaluation of the ship hull as a whole. The CAP rating is assigned according to the following criteria:

overall condition of the structure (refer to [Table 3.2.2-1](#)), condition of the protective coating (refer to [Table 3.2.2-2](#)), overall technical condition of the anchoring arrangement (refer to [Table 3.2.2-3](#)), condition of cathodic protection (refer to [Table 3.2.2-4](#)) with respective CAP rating (refer to [Table 3.2.2-5](#));

technical condition based on the results of assessment of the ship hull strength with respective CAP rating (refer to [Table 3.2.2-6](#));

technical condition based on the results of assessment of the hull structure actual wear with respective CAP rating (refer to [Table 3.2.2-7](#)).

3.2.2.1 The total CAP rating for the "HULL" group is assigned as an average value of assessment by 3 criteria according to [Tables 3.2.2-5 to 3.2.2-7](#). The total rating shall not exceed the rating given in [Table 3.2.2-5](#). In case CAP3 or CAP4 rating is assigned by at least one of the criteria according to [Tables 3.2.2-5 to 3.2.2-7](#) the total rating shall not exceed CAP3 or CAP4 respectively.

Table 3.2.2-1

Verbal description	Criteria for assessment of overall condition of hull structures, superstructures, deckhouses, closures of openings in outer envelope of the ship based on results of visual examination
Good	Structures, their welded joints are not damaged or have sporadic defects. A small amount of defects such as smooth bulging, corrugation of plating and flooring, which are within the tolerances specified in the RS rules is allowed. Tightness and structural integrity of the examined items are intact.
Satisfactory	Structures, their welded joints have visible defects, which do not significantly affect the bearing capacity of the structure: residual deformations, pitting corrosion, which are within the tolerances specified in the RS rules. Tightness and structural integrity of the examined items are intact.
Unsatisfactory	Structures, their welded joints have defects, which slightly exceed or equal to the tolerances specified in the RS rules. Tightness and structural integrity of the examined items are intact. Repair is required.

Verbal description	Criteria for assessment of overall condition of hull structures, superstructures, deckhouses, closures of openings in outer envelope of the ship based on results of visual examination
Poor	Structures, their welded joints have defects, which considerably exceed the tolerances specified in the RS rules. Tightness and structural integrity of the examined items are damaged. Complete and urgent repair is required to restore serviceability.

Table 3.2.2-2

Verbal description	Criteria for assessment of protective coating condition
Good	Coating condition with spot corrosion on the area of less than 3 % of the area under consideration without visible coating damage. Corrosion at edges of stiffeners or welded joints is less than 20 % of the areas under consideration.
Fair	Condition with coating damage or corrosion propagation on the area of less than 20 % of the area under consideration. The area of the solid corrosion layer propagation is less than 10 % of the area under consideration. Corrosion at edges of stiffeners or welded joints is less than 50 % of the areas under consideration.
Poor	Condition with coating damage or corrosion propagation area more than 20 % or with solid corrosion layer more than 10 % of the area under consideration or local failure concentrated at edges of stiffeners or welded joints more than 50 % of the areas under consideration.

Table 3.2.2-3

Verbal description	Criteria for assessment of the anchoring arrangement condition
Good	Actual wear of anchor chain components is within the tolerance and equal to not more than 50 % of limit values.
Satisfactory	Actual wear of anchor chain components is within the tolerance and equal to more than 50 % of limit values
Poor	Actual wear of anchor chain components exceeds the allowable limit values.

Table 3.2.2-4

Verbal description	Criteria for assessment of cathodic protection condition
Superior	Anode consumption is from 0 to 25 %
Good	Anode consumption is from 25 to 50 %
Satisfactory	Anode consumption is from 50 to 65 %
Poor	Anode consumption is from 75 to 100 %

Table 3.2.2-5

CAP rating	Criteria for assigning CAP rating based on the results of technical condition and coating condition assessment
CAP1	Overall condition of the structure is assessed as "good". Condition of coating, where applicable, is assessed as "good".
CAP2	Overall condition of the structure is assessed as "satisfactory". Condition of coating, where applicable, is assessed as "satisfactory" or "good".
CAP3	Overall condition of the structure is assessed as "unsatisfactory". Condition of coating, where applicable, is assessed as "poor" or "satisfactory".
CAP4	Overall condition of the structure is assessed as "poor". Condition of coating, where applicable, is assessed as "poor".

Table 3.2.2-6

CAP rating	Criteria for assigning CAP rating based on the results of strength assessment
CAP1	Actual hull strength is not less than 98 % of the values required for a new ship.
CAP2	Actual hull strength is not less than 95 % of the values required for a new ship.
CAP3	Actual hull strength is not less than 90 % of the values required for a new ship.
CAP4	Actual hull strength is less than the values required to retain the ship's class.

Table 3.2.2-7

CAP rating	Criteria for assigning CAP rating based on the results of the hull structure actual wear assessment
CAP1	Minor wear (not more than 35 % of limit values) of hull members is allowed.

CAP rating	Criteria for assigning CAP rating based on the results of the hull structure actual wear assessment
CAP2	Actual wear of hull members is within the tolerance and equal to not more than 75 % of limit values.
CAP3	Actual wear of hull members is within the tolerance but exceeds 75 % of limit values.
CAP4	Actual wear of separate hull members exceeds limit values to retain the ship's class.

3.2.3 Four-grade rating scale by four criteria is used as a rating system for the "MACHINERY, SYSTEMS" group (refer to [Table 3.2.3-1](#)):

assessment of overall technical condition based on results of visual examination (refer to [Table 3.2.3-2](#)); assessment of overall technical condition based on results of functional and operational tests (refer to [Table 3.2.3-3](#));

assessment of overall technical condition based on results of diagnostic parameter assessment (refer to [Table 3.2.3-4](#)); assessment of maintenance and availability of spare parts (refer to [Table 3.2.3-5](#)).

Table 3.2.3-1

CAP rating	Criteria for assigning CAP rating for "MACHINERY, SYSTEMS" group
CAP1	Overall technical condition based on results of visual examination is assessed as "good" or "satisfactory". Overall technical condition based on results of functional and operational tests is assessed as "good". Overall technical condition based on results of diagnostic parameter assessment is assessed as "good". Maintenance and availability of spare parts are assessed as "good".
CAP2	Overall technical condition based on results of visual examination is assessed as "good" or "satisfactory". Overall technical condition based on results of functional and operational tests is assessed as "satisfactory". Overall technical condition based on results of diagnostic parameter assessment is assessed as "good". Maintenance and availability of spare parts are assessed as "good" or "satisfactory".
CAP3	Overall technical condition based on results of visual examination is assessed as "unsatisfactory". Overall technical condition based on results of functional and operational tests is assessed as "unsatisfactory". Overall technical condition based on results of diagnostic parameter assessment is assessed as "good". Maintenance and availability of spare parts are assessed as "satisfactory".
CAP4	Overall technical condition based on results of visual examination is assessed as "poor". Overall technical condition based on results of functional and operational tests is assessed as "poor". Overall technical condition based on results of diagnostic parameter assessment is assessed as "poor". Maintenance and availability of spare parts are assessed as "poor".

Table 3.2.3-2

Verbal description	Criteria for assessment of overall technical condition based on results of visual examination
Good	No visible defects are detected. Condition of coating is "good". No leakage traces are detected.
Satisfactory	Minor damages, which do not affect safe operation, are detected. No leakage traces are detected.
Unsatisfactory	Damages, which are within limit values to retain the ship's class and which do not affect safe operation but require maintenance and repair, are detected. No leakage traces are detected.
Poor	Damages, which may affect safe operation are detected. Leakage traces are detected.
N/A (Not applicable)	Type of the system under consideration or its component due to structural features or functionality does not allow to assign a respective verbal description.

Table 3.2.3-3

Verbal description	Criteria for assessment of overall technical condition based on results of functional and operational tests
Good	Items and systems are surveyed, functionally and operationally tested. Performance corresponds to the manufacturer's requirements and requirements to retain the ship's class. Equipment control and safety devices are completely serviceable.
Satisfactory	Items and systems are surveyed, functionally and operationally tested. Minor faults and deviations from the required performance which do not affect safe operation of the equipment and do not require maintenance or repair are detected. Equipment control and safety devices are completely serviceable.
Unsatisfactory	Items and systems are surveyed, functionally and operationally tested. Performance insignificantly exceeds or are within the limits specified in the RS rules. Faults, which do not affect safe operation of the equipment but require maintenance and repair, are detected. Equipment control and safety devices are completely serviceable.
Poor	Faults, which may affect safe operation of the equipment, are detected. Performance is considerably lower than the required values to retain the ship's class. Faults in the equipment control and safety devices are detected. Immediate actions are required to restore serviceability
N/A (Not applicable)	Type of the system under consideration or its component due to structural features or functionality does not allow to assign a respective verbal description.

Table 3.2.3-4

Verbal description	Criteria for assessment of overall technical condition based on results of diagnostic parameter assessment (vibration, oil analysis, bearing clearances, etc.)
Good	Diagnostic parameters of equipment are within the tolerance. Oil sample results are within the tolerance. Elevated equipment vibration is not detected.
Poor	Diagnostic parameters do not correspond to the tolerance. Oil sample results exceed the tolerance. Elevated equipment vibration is detected.
N/A (Not applicable)	Type of the system under consideration or its component due to structural features or functionality does not allow to assign a respective verbal description.

Table 3.2.3-5

Verbal description	Criteria for assessment of maintenance and availability of spare parts
Good	Regular maintenance of equipment, availability of schedules and application of diagnostic equipment are documented. Quantity and nomenclature of spare parts correspond to the recommendations of the manufacturer and the RS normative documents. The information on storage location of spare parts, records on availability, consumption and order system of spare parts is available.
Satisfactory	The minimum scope of maintenance performed according to the recommendations of the manufacturer and the RS normative documents is documented. Deviations from the recommended quantity and nomenclature of spare parts are detected. The information on storage location of spare parts, records on availability, consumption and order system of spare parts is available. Minor deficiencies, which do not affect safe operation of the equipment, are allowed.
Poor	Significant faults in maintenance of the equipment which may affect safe operation of the equipment are detected. The information on storage location of spare parts, records on availability, consumption and order system of spare parts is not available
N/A (Not applicable)	Type of the system under consideration or its component due to structural features or functionality does not allow to assign a respective verbal description.

3.2.4 In case the elements having condition below the minimum requirements specified in the RS rules for the RS-classed ships are detected, the Register reserves the right to require elimination of detected defects (refer to Section 4.7 of Part I "General" of the Rules TSSS).

3.2.5 For ACS-classed ships subject to CAP, the Register shall notify the shipowner in writing on detected elements having condition below the minimum requirements and necessity to inform the corresponding classification society about this matter.

3.3 CAP OPERATIONS EXECUTION

3.3.1 CAP procedure of the Register includes the following main stages:

- Filling up a request for CAP on the RS website (refer to <https://rs-class.org/services/condition-assessment-program-cap/>);
- analysis of the shipowner's Request (in particular, it is necessary to determine whether the ship is subject to the Register CAP procedure, in accordance with [3.1.3](#));
- review of documents;
- performance of fatigue life calculations for compliance with CAP criteria in accordance with [3.7](#) (if applicable);
- preparation to survey and performance of survey;
- preparation and issue of the Preliminary Statement on Condition Assessment Program (Form 3.1.12.1) (upon the shipowner's request);
- performance of hull strength calculations for compliance with CAP criteria (for assessing a rating score for the "HULL" group), in accordance with [3.6](#);
- sending a Letter of Conclusion to the shipowner on the performance of hull strength calculations for compliance with the CAP criteria (for assigning a rating score for the "HULL" group);
- preparation and issue of the CAP Report, in accordance with [3.8](#);
- preparation and issue of the CAP Certificate (Form 3.1.12) (for CAP1 and CAP2) or a Letter of Conclusion (for CAP3 and CAP4).

A CAP Operations Flow Chart is given in [Appendix 1](#).

3.3.2 A Preliminary Statement on Condition Assessment Program (Form 3.1.12.1) can be issued by RHO upon the shipowner's request. This document confirms that CAP is currently in progress for the ship and indicates the preliminary CAP rating of the ship based on the analysis of the survey results and documents submitted by the shipowner.

3.3.3 A shipowner is responsible to ensure safe survey of the ship by the Register. To ensure safety of the CAP survey, the shipowner shall comply with the applicable requirements of the Rules TSSS (at least, Sections 3.3 and 4.2 of Part I "General" of the Rules TSSS, Section 4 of Part II "Classification Surveys" of the Rules TSSS).

3.4 REVIEW OF DOCUMENTS

3.4.1 The list of information submitted by the shipowner is given in [Section 2](#).

3.4.2 During preparation for CAP execution as per the shipowner's Request, the Register reviews the following documents included in the Ship's File and/or received from the shipowner:

Classification Certificate and other certificates, if any;

current ship surveys status;

RS reports, checklists (or, if applicable, ACS-IACS member), at least the last special and subsequent surveys of the ship (to specify the status and presence of any recurring failures, as well as repair and survey history);

reports on hull condition, reports on thickness measurements, repair reports, history of ship hull damages, transported cargoes, areas of ship operation and other documents on actual condition of ship hull for the operation period preceding the CAP procedure execution;

planned maintenance system (PMS) documentation, if any, for machinery and cargo system (maintenance schedules; documents confirming fulfilment of the PMS operations and schedules); documents demonstrating technical condition before and after maintenance; records on accidents, failures and emergencies, replacement and repair of CAP items;

records on technical condition and/or worksheets for checking technical condition of machinery, or special forms of records on the results of technical condition monitoring during the maintenance. The documents submitted shall contain the results of surveys and measurements carried out during the maintenance, as well as the limit values of technical condition parameters (sizes, clearances, condition of surfaces, etc.) determined by the manufacturer or other recognized organization. Causes of failures, accidents, replacements and repairs shall be specified.

3.4.3 Upon request of the Register, the shipowner and/or the RS Branch Office for in-service supervision shall provide additional information and ship documents required for the CAP execution.

3.4.4 The Register performs review of information on hull defects appeared within the first 10 years of ship operation, recurring defects, accidents as well as their causes and elimination methods.

3.4.5 Based on the reviewed documentation, the Register shall make a decision on possibility to execute the CAP procedure for a ship, preliminary conclusions on the surveys carried out, requirements to be met, ship condition, operating conditions of the shipboard machinery, etc., determine the items subject to closer attention, specify the scope of surveys, measurements, tests and checks.

3.4.6 If during review of the documents some doubts on possibility of issue of the CAP Certificate appear, the Register may offer to perform preliminary assessment, including strength analysis based on the existing fault detection reports, repair lists and reports on survey. Upon review of the preliminary assessment results, the shipowner shall make a decision on expediency of the CAP execution and inform the Register.

3.5 SURVEY WITHIN THE CAP FRAMEWORK

3.5.1 The scope of survey within the CAP framework is determined in each particular case depending on the groups of items (refer to [3.1.2](#)), subject to assessment and specified by the shipowner in the Request as well as the requirements of the Rules TSSS with reference to age and class of the ship as well as type of survey and shall include, at least, the following:

.1 for Request for assessment of "HULL" group items:

annual survey of the hull, survey of anchoring arrangement and steering gear, rudder blade, propellers and active means of ship steering in the scope of annual survey for the ships up to 5 years of age. For the RS-classed ships without class or from society-non-IACS member, it is required to perform random thickness measurements of the elements of the hull, superstructure, deckhouses and closures of openings in outer envelope of the ship;

for the ships of 5 years of age and above, special survey of the hull, anchoring arrangement and steering gear, rudder blade, propellers and active means of ship steering in the scope of annual survey.

When aligning the CAP surveys with special or intermediate survey, the scope of the CAP survey shall correspond to special or intermediate hull survey respectively.

The minimum number of measured cross sections shall comply with 4.2.2.4.7 of Part II "Classification Surveys" of the Rules TSSS.

.2 for Request for assessment of the "MACHINERY, SYSTEMS" group items:

annual survey of machinery, systems, including cargo system, arrangements and electrical equipment of the ship.

When aligning the CAP surveys with special or intermediate survey, the scope of the CAP survey shall correspond to the scope of special or intermediate survey respectively.

3.5.2 When assigning the scope of the CAP survey for the "HULL" group, the following may be partially considered:

results of the previous special/intermediate classification survey performed by RS or ACS-IACS member not earlier than 12 months before the shipowner's application;

results of thickness measurements carried out under technical supervision of RS or ACS-IACS member not earlier than 12 months before the shipowner's application. In case the results of measurements carried out under technical supervision of ACS-IACS member are taken into consideration, check measurements of thickness under the RS surveyor supervision shall be carried out.

3.5.3 The possibility of aligning the CAP survey with periodical classification surveys shall be decided by the Register in each particular case on the basis of the shipowner's Request and review of documents.

3.5.4 When aligning the CAP surveys with periodical classification survey, the CAP report documents shall be prepared separately. Defects detected during the CAP survey shall be documented in the RS records in a proper manner.

3.5.5 The CAP Report may include the data from several ship surveys provided that the period between the completion of the first and last of these surveys does not exceed 6 months.

3.5.6 Intersection nodes of primary longitudinal members with transverse deep members recognized by the results of fatigue life calculation as potentially critical (refer to [3.7](#)) shall be included into the close-up CAP survey plan.

3.5.7 It is recommended to include potentially critical intersection nodes of primary longitudinal members with transverse deep members into the list of areas for close-up survey during subsequent ship surveys.

3.5.8 The CAP survey results for the "HULL" group shall be prepared by the RS surveyor carrying out a survey in the form of a Checklist on ship CAP HULL survey. A respective checklist shall be prepared by the RS surveyor(s) based on the survey results for each item/space including, at least, the following:

bottom shell plating along the ship's length;

portside and starboard shell plating along the ship length;
deck and platform plating;
sacrificial anode protection of shell plating, if any;
thruster, if any;
anchoring arrangement;
steering gear and rudder blade;
propeller or active means of ship steering (as applicable).
superstructure/deckhouse walls;
each cargo hold/tank on board the ship;
each ballast tank on board the ship;
each void space;
closures of openings in outer envelope.

3.5.9 Photos of each surveyed space/item proving technical condition of the item at the moment of survey shall be attached to the records. Photos taken by the RS surveyor shall be clearly identified and drawn up in accordance with [Appendix 4](#). This information shall correspond to the information on the item shown in the photo. Generally, 4 to 8 photos shall be made for each surveyed item/space.

3.5.10 Where applicable, reports and results of survey tests and measurements shall be attached to the filled-in forms of the documents.

3.5.11 The CAP survey results for the "MACHINERY, SYSTEMS" group are prepared by the RS surveyor carrying out a survey in the form of a Checklist on Ship CAP MACHINERY, SYSTEMS survey. A respective checklist shall be prepared by the RS surveyor(s) based on the survey results for each item/system component including, at least, the following:

each main engine (with auxiliary machinery, arrangements and systems as well as engine room as a whole);

each auxiliary engine (with auxiliary machinery and arrangements);

each main and emergency power source (with auxiliary machinery and switchgear assemblies);

all liquid cargo system components of oil tankers (including associated pumps, pipelines, valves, instrumentation, machinery and arrangements, safety systems as well as associated spaces on the ship as a whole);

all ballast system components (including associated pumps, pipelines, valves, instrumentation, machinery and arrangements);

anchoring arrangement, steering gear, thrusters and mooring gear (with auxiliary machinery and arrangements);

propeller, intermediate and thrust shafts (as applicable).

3.5.12 Photos of each surveyed space/item proving technical condition of the item at the moment of survey shall be attached to the records. Photos taken by the RS surveyor shall be clearly identified and drawn up in accordance with [Appendix 4](#). This information shall correspond to the information on the item shown in the photo. Generally, 1 to 2 photos shall be made for each surveyed item/space.

3.5.13 Where applicable, reports and results of survey tests and measurements shall be attached to the filled-in forms of the documents.

3.6 HULL STRENGTH CALCULATIONS FOR COMPLIANCE WITH CAP CRITERIA

3.6.1 To assign a CAP rating to the ship hull for the "HULL" group, additionally to the rating received as a result of ship hull CAP survey, the hull strength calculations for compliance with the CAP criteria shall be carried out.

3.6.2 Strength calculations shall be fulfilled to assign the CAP rating for ship hull and include the following:

- analysis of ship hull actual condition with the description of actual wear and other defects detected both during survey and upon results of studying the data of previous repairs of the hull, classification society reports, etc.;

- check of the ship hull longitudinal strength according to the thickness measurements in transverse sections, in compliance with [3.5.1.1](#), including comparison of the actual hull section modulus with allowable values specified in the RS rules valid on the date of receipt of the application as per the RS requirements for CAP1, CAP2 and CAP3 ratings ([refer to 3.2.1](#));

- check of the ship hull geometric characteristics, including comparison of actual thickness of plates and beam webs of hull wearable members with the RS requirements for CAP1, CAP2 and CAP3 ratings ([refer to 3.2.1](#));

- check of geometric characteristics of ship hull with wear for absence of CAP4 rating elements (if any, the overall CAP rating becomes CAP4);

- graphical representation of cumulative hull structure wear curves and CAP rating evaluation for each structural group. CAP rating is determined with 10 % coverage (90 % cumulative level) for all taken measurements for each structural group. Recommendations for the plotting of cumulative distribution curves of thickness diminutions (wear curves) of hull structures are given in [Appendix 3](#).

3.7 HULL FATIGUE LIFE ASSESSMENT FOR COMPLIANCE WITH CAP CRITERIA

3.7.1 Upon the shipowner's request, an assessment of the fatigue life of hull structures may be carried out prior to commencement of the ship survey.

3.7.2 The purpose of this assessment is to identify potentially critical hot spots as regards fatigue life and to include them in the close-up survey plan.

3.7.3 Fatigue life assessment shall be performed in the Register's specialized software for checking hull structures for compliance with the requirements of the rules, taking into account the following provisions:

the linear cumulative damage model (the Palmgren-Miner's Rule) and the design S-N curves (according to IACS recommendation No. 56 "Fatigue Assessment of Ship Structures") shall be applied;

wave load calculations are performed by statically placing the vessel on a wave of equivalent height. The design height of the equivalent wave determined at 10^{-2} probability level of exceedance, according to the data on the wind-wave environment of the North Atlantic;

the long-term distribution of stress ranges of a structural detail is assumed to follow a two-parameter Weibull distribution; the shape coefficient ξ is taken equal to 1 at a stress range probability of exceedance of 10^{-2} ;

the design fatigue life is calculated for the intersection nodes of primary longitudinal members, contributing to the hull longitudinal strength, with transverse deep members (including beams of the upper deck, bottom, double bottom, side, double side skin and longitudinal bulkheads, as well as for continuous beams located on bottom stringers and horizontal diaphragms of the double hull);

the intersection nodes of primary longitudinal members with transverse deep members at each web frame as well as at the transverse bulkheads in the midship section (within $0,4 L$) shall be considered;

the calculation shall consider the hull girder bending and local stresses, as well as stresses caused by relative displacements (the latter — only for the intersection nodes of primary longitudinal members with transverse bulkheads and with deep members adjacent to transverse bulkheads);

the calculation is performed for the as-built ship design, taking into account the corresponding corrosion allowance;

the calculation does not take into account actual wear and the impact of the ship actual operating history on the condition of hull structures;

hot spots which design fatigue life is shorter than the ship's service life at the time of application plus 5 years shall be considered potentially critical (refer to [3.7.4](#)).

3.7.4 The survey method for calculated structures shall be selected in accordance with [Table 3.7.4](#).

Table 3.7.4

Criterion	Survey method
$FTL > Y+5$	Overall survey
$FTL \leq Y+5$	Close-up survey

Note. FTL — design fatigue life obtained from the calculation.
 Y — ship age at the proposed date of survey, or, if this date has not yet been determined, — at the date of calculation.

3.7.5 The report with calculation results shall include:
 description of calculation procedure;
 version of used software;
 calculations sequence and details;
 report from the software package in which the calculations were performed;

calculation results in graphical form for each hot spot with their location identified relative to the hot spot under consideration;

list of potentially critical hot spots for close-up survey (if any are identified by the calculation).

3.7.6 Recommendations for drawing up results of the calculation are given in [Appendix 5](#).

3.7.7 Recommendations on drawing up a list of potentially critical intersection nodes of primary longitudinal members with transverse deep members are given in [Appendix 6](#).

3.8 CAP REPORT

3.8.1 The CAP Report for the "HULL" group shall contain, at least, the following main sections:

general information on the ship, including status of classification and statutory surveys of the ship;

description of the system used to assign ratings and descriptive notations;

Checklist on Ship CAP HULL Survey, photos confirming technical condition;

calculation of hull strength for compliance with the CAP criteria to assess the longitudinal and local strength as well as fatigue life for the "HULL" group;

information on the performed repair of the hull structures prepared according to [Appendix 2](#);

calculation of CAP rating for the hull ("HULL" group);

conclusion.

3.8.2 The CAP Report for the "MACHINERY, SYSTEMS" group shall contain, at least, the following main sections:

general information on the ship, including status of classification and statutory surveys of the ship;

Checklist on Ship CAP MACHINERY, SYSTEMS Survey, photos confirming technical condition;

information on the performed repair of the machinery and systems prepared according to [Appendix 2](#);

calculation of CAP rating for ship's machinery and cargo systems;

calculation of overall CAP rating ("MACHINERY, SYSTEMS" group);

conclusion.

3.8.3 When performing CAP for two groups ("HULL" and "MACHINERY, SYSTEMS" groups), it is allowed to prepare one report containing information provided in [3.8.1](#) and [3.8.2](#).

3.8.4 When performing CAP for two groups ("HULL" and "MACHINERY, SYSTEMS" groups) in the CAP Certificate (Form 3.1.12) rating score shall be specified for each group (for example, CAP1 — HULL and CAP2 — MACHINERY, SYSTEMS).

3.8.5 The CAP Certificate (Form 3.1.12) shall not be issued in case of assigning CAP3 and CAP4 ratings to the ship. The Letter of Conclusion with the CAP Report containing CAP rating justification shall be sent to the shipowner and the RS Branch Office for in-service supervision.

CAP WORKFLOW



RECOMMENDATIONS FOR THE DESIGN OF CUMULATIVE DISTRIBUTION CURVE OF THICKNESS DIMINUTIONS OF HULL STRUCTURES

In accordance with [3.6.2](#), the results of actual strength calculations shall be presented in graphical form, using the cumulative distribution curves of thickness diminutions (wear curves) of hull structures with an assessment of the CAP rating for each structural member group. The CAP rating is determined with 10 % coverage (90 % cumulative level) for all performed measurements for each structural member group.

At least the following groups of members shall be considered:

- plates and beams of side shell plating;
- plates and beams of strength deck plating;
- plates and beams of bottom shell plating with bilges;
- plates and beams of double bottom plating (including inclined plating connecting the inner bottom with the inner side, bottom stringers and vertical keel);
- plates and framing of inner side (horizontal diaphragms of double hull);
- plates and beams of longitudinal bulkheads;
- longitudinal coamings.

The cumulative distribution curves of thickness diminutions (wear curves) are a distribution function of the probability obtained values of thickness diminutions of hull structures and describe the probability that the thickness diminution of the structure of any given structural element within a group will be less than or equal to a specific wear level (expressed as a percentage). Another names: "integral distribution function" or "cumulative distribution function".

The cumulative distribution curves of thickness diminutions can be developed using software for statistical data processing or MS Excel (refer to [Fig. 3-1](#)). This Figure shows that 90 % of the hull structures of a certain group of structural members have actual thickness diminution of less than 35 % of the allowable by RS rules. Therefore, this structural members group is assigned a CAP1 rating.

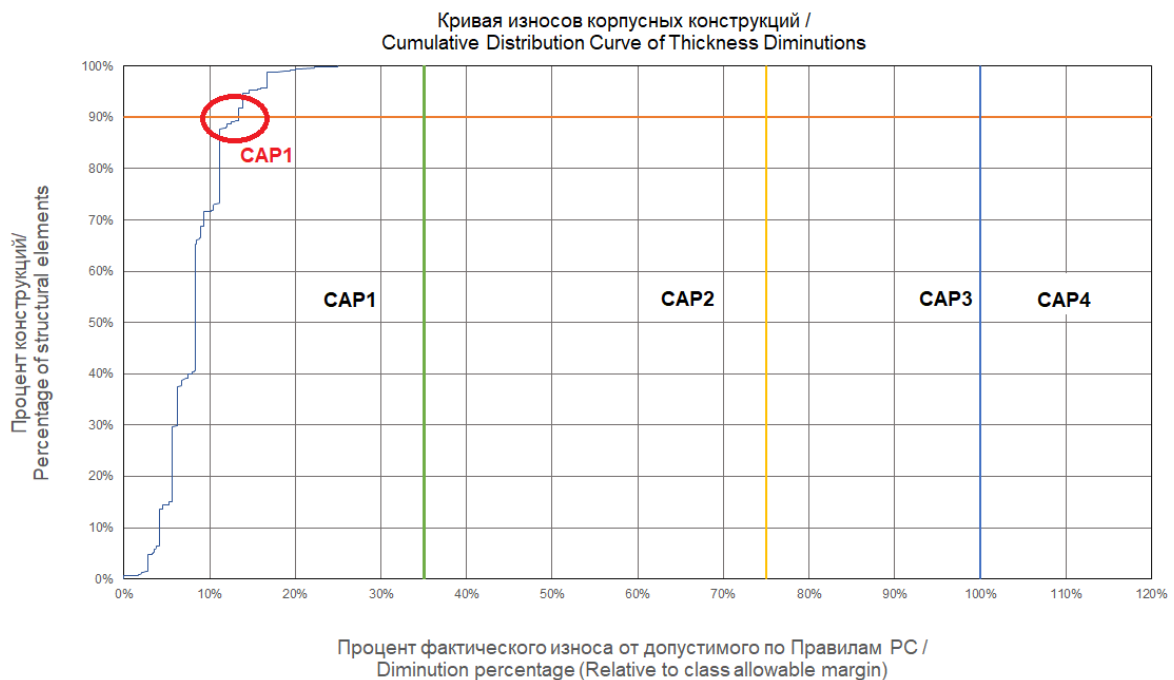

Fig. 3-1. The cumulative distribution curve of thickness diminutions.

THE STRUCTURE OF APPENDIXES WITH PHOTO MATERIALS BASED ON RESULTS OF THE SHIP SURVEY FOR THE CAP REPORT

In accordance with [3.5.8](#) and [3.5.9](#), based on the results of the ship survey, the photo materials are drawn up as Appendixes to the CAP Report.

When performing CAP for items of the "HULL" group, the following Appendix structure is used:

APPENDIX 1.2 — HULL PHOTO REPORT

- Ship's superstructure/deckhouse (from outside);
- Underwater and above water hull area upper deck incl. (from outside);
- Rudder, tailshaft and thruster;
- Cathode protection;
- Propeller;
- Anchor and anchor chain;
- Bow thruster;
- Closures of openings;
- Close-up surveys;
- Water ballast tanks (list titles);
- Forepeak;
- Afterpeak;
- Cargo and Slop Tanks.

When performing CAP for items of the "MACHINERY, SYSTEMS" group, the following Appendix structure is used:

ANNEX 2.2 — MACHINERY PHOTO REPORT

- Survey of machinery spaces;
- Main engine;
- Reduction gear;
- Survey of auxiliary engines (Aux diesel generator):
 - No. 1;
 - No. 2;
 - No. 3;
- Survey of power generation and distribution system:
 - Electrical transformer No. 1;
 - Electrical transformer No. 2;
 - Emergency diesel generator;
 - Main switch board;
 - Fuel oil system;
 - Lubricating oil system;
 - Survey of compressed air system;
 - Survey of sea water system;
 - Survey of fresh water system;
 - Survey of fire systems;
 - Survey of steam and feed systems;
 - Survey of bilge system;
 - Survey of steering gear hydraulic system;
 - Survey of control and safety devices;
 - Survey of anchoring and mooring equipment.

ANNEX 2.3 — CARGO SYSTEM PHOTO REPORT

Survey of pump room (Cargo control console);

Survey of pump room;

Survey of cargo transfer system;

Survey of ballast transfer system;

Survey of inert gas system;

Survey of control and safety devices.

RECOMMENDATIONS FOR DRAWING UP RESULTS OF FATIGUE LIFE CALCULATION

In accordance with [3.7.5](#), the results of fatigue life calculations shall be presented graphically for each hot spot, with their location identified relative to the intersection node under consideration. An example of calculation results is shown in [Fig. 5-1](#).

Depending on the results obtained, each cell corresponding to a hot spot considered during the calculation is assigned one of three colors: blue, green or red. The color of the cell depends on the result of comparing the design fatigue life and the ship service life at the time of application + 5 years. In the example shown in [Fig. 5-1](#), the service life of the ship at the time of application was 15 years. A list of the intersection nodes of primary longitudinal members with transverse deep members, that correspond red cells in [Fig. 5-1](#), shall be submitted for close-up survey.

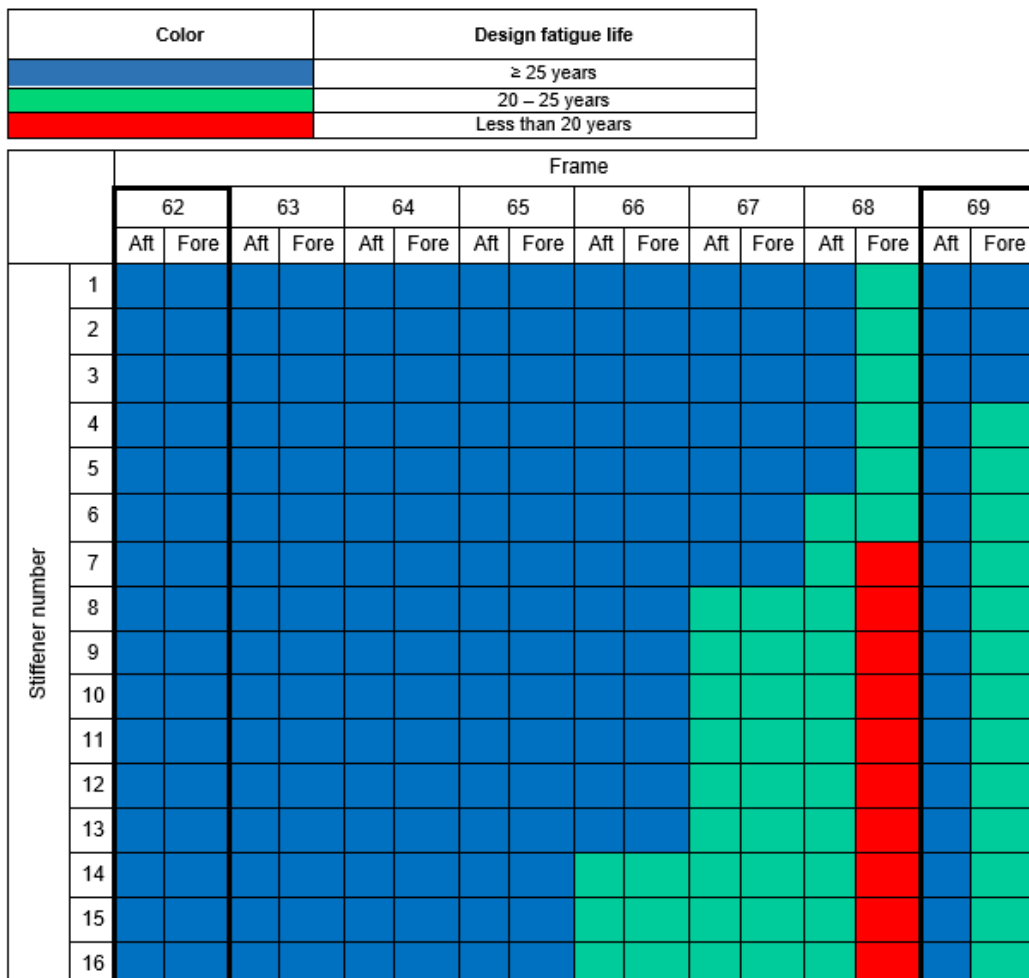

Fig. 5-1
Example of fatigue life calculation results

RECOMMENDATIONS ON DRAWING UP A LIST OF POTENTIALLY CRITICAL INTERSECTION NODES OF PRIMARY LONGITUDINAL MEMBERS WITH TRANSVERSE DEEP MEMBERS

In accordance with [3.7.5](#), the fatigue life calculation report shall include a list of identified potentially critical intersection nodes of primary longitudinal members with transverse deep members (if applicable).

The list shall contain the information about the identified potentially critical hot spots as follows:

- compartment name;
- longitudinal location onboard (frame number);
- description of structures which make up the assembly under consideration;
- number of a longitudinal frame in accordance with design documentation;
- number of an intersection node of primary longitudinal members with transverse deep members (list of typical hot spots is given in [Appendix 7](#));
- designation of the assembly area to be surveyed (the designation of a hot spot and its position relative to the frame under consideration shall be indicated).

An example of such list is given in [Fig. 6-1](#):

Compartment	Frame	Connecting assembly	Longitudinal frame number	Connection type number	Hot spot for survey
	59	of side longitudinal with double hull diaphragm	33 — 38	1	B (fore end)
Bulkhead	60	of bulkhead longitudinal with transverse bulkhead at centerline	44 — 47	26	B (aft end)
		of side longitudinal with transverse bulkhead	33 — 37	26	B (fore end)
WBT No.5	61	of side longitudinal with double hull diaphragm	33, 36 — 38, 34	1, 13, 1	A (aft end) A, B (fore and aft end)
	62	of side longitudinal with double hull diaphragm	34	1	B (fore end)
	63	of side longitudinal with double hull diaphragm	34	1	B (fore end)
	64	of side longitudinal with double hull diaphragm	34	1	B (fore end)
	65	of side longitudinal with double hull diaphragm	34	1	B (fore end)
		of bottom longitudinal with flooring	18, 22, 23	1, 13	B (fore end) B (fore end)
	66	of bottom longitudinal with flooring	3 — 21, 22 — 23	1, 13	B (fore end) A, B (fore and aft end)
of side longitudinal with double hull diaphragm		32 — 38	1, 13	B (fore end)	

Fig. 6-1

List of potentially critical intersection nodes of primary longitudinal members with transverse deep members

**LIST OF TYPICAL CONNECTION TYPES OF INTERSECTION NODES
OF PRIMARY LONGITUDINAL MEMBERS
WITH TRANSVERSE DEEP MEMBERS**

Table 7-1

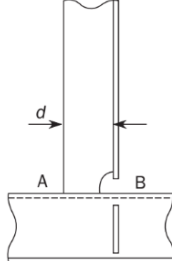
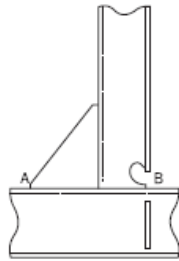
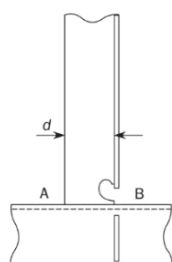
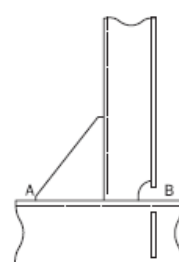
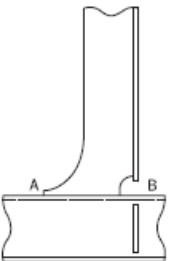
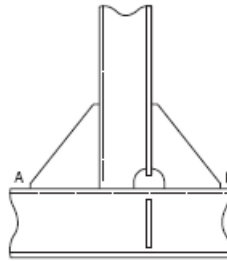
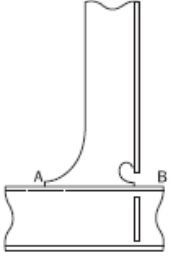
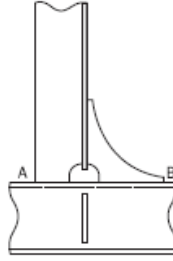
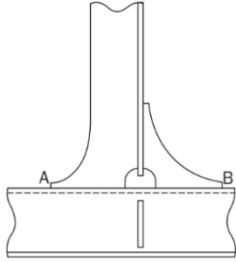
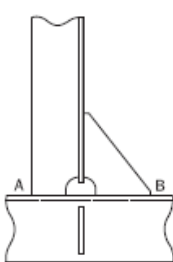
No.	Connection type	No.	Connection type
1		6	
2		7	
3		8	
4		9	
5		10	

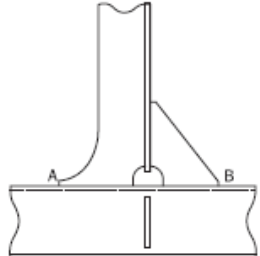
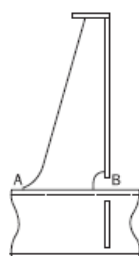
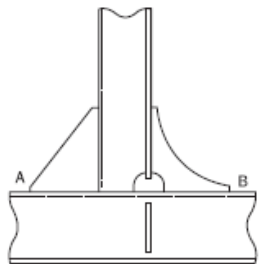
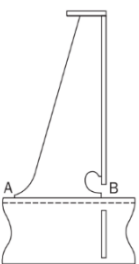
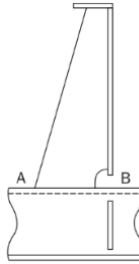
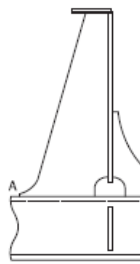
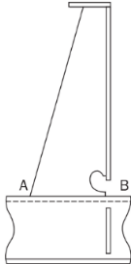
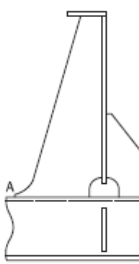
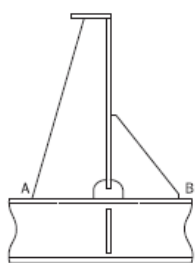
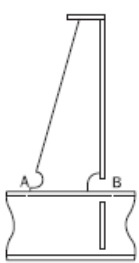
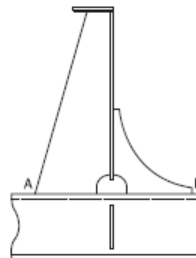
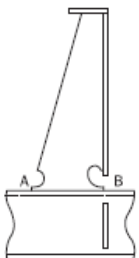
No.	Connection type	No.	Connection type
11		17	
12		18	
13		19	
14		20	
15		21	
16		22	

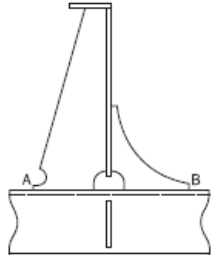
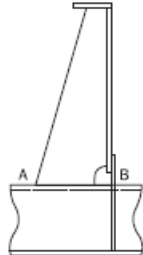
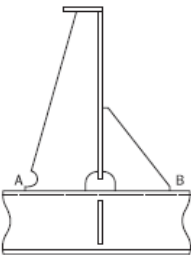
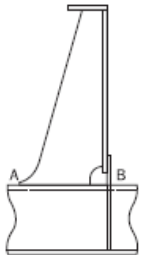
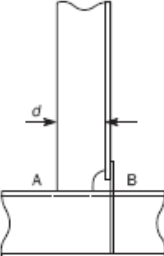
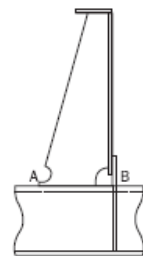
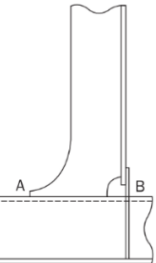
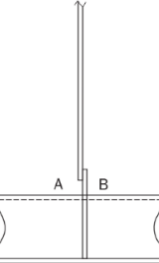
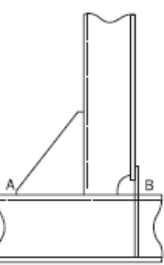
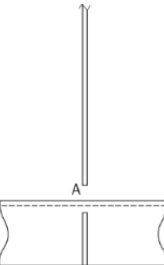
No.	Connection type	No.	Connection type
23		28	
24		29	
25		30	
26		31	
27		32	

Russian Maritime Register of Shipping

Guidelines on the Condition Assessment Program (CAP)

FAI "Russian Maritime Register of Shipping"
7, Litera A, Millionnaya Ulitsa
St. Petersburg, 191186
Russian Federation
www.rs-class.org/en/