

RULES

FOR THE CLASSIFICATION, CONSTRUCTION AND EQUIPMENT OF MOBILE OFFSHORE DRILLING UNITS AND FIXED OFFSHORE PLATFORMS

PART XV

MODU AND FOP SAFETY ASSESSMENT

ND No. 2-020201-019-E



**St. Petersburg
2022**

RULES FOR THE CLASSIFICATION, CONSTRUCTION AND EQUIPMENT OF MOBILE OFFSHORE DRILLING UNITS AND FIXED OFFSHORE PLATFORMS

Rules for the Classification, Construction and Equipment of Mobile Offshore Drilling Units (MODU) and Fixed Offshore Platforms of (FOP) of Russian Maritime Register of Shipping (RS, the Register) have been approved in accordance with the established approval procedure and come into force on 1 July 2022.

The present edition of the Rules is based on the 2018 edition taking into account the amendments and additions developed before publication.

The Rules set down specific requirements for MODU and FOP, consider the recommendations of the Code for the Construction and Equipment of Mobile Offshore Drilling Units (MODU Code), as adopted by the IMO Assembly on 2 December 2009 (IMO resolution A.1023(26)).

The procedural requirements, unified requirements, unified interpretations and recommendations of the International Association of Classification Societies (IACS) and the relevant resolutions of the International Maritime Organization (IMO) have been taken into consideration.

The Rules are published in the following parts:

Part I "Classification";

Part II "Hull";

Part III "Equipment, Arrangements and Outfit of MODU/FOP";

Part IV "Stability";

Part V "Subdivision";

Part VI "Fire Protection";

Part VII "Machinery Installations and Machinery";

Part VIII "Systems and Piping";

Part IX "Boilers, Heat Exchangers and Pressure Vessels";

Part X "Electrical Equipment";

Part XI "Refrigerating Plants";

Part XII "Materials";

Part XIII "Welding";

Part XIV "Automation";

Part XV "MODU and FOP Safety Assessment";

Part XVI "Signal Means";

Part XVII "Life-Saving Appliances";

Part XVIII "Radio Equipment";

Part XIX "Navigational Equipment";

Part XX "Equipment for Prevention of Pollution".

These Rules supplement the Rules for the Classification and Construction of Sea-Going Ships and the Rules for the Equipment of Sea-Going Ships.

REVISION HISTORY

(purely editorial amendments are not included in the Revision History)

For this version, there are no amendments to be included in the Revision History.

1 GENERAL

1.1 APPLICATION

1.1.1 The requirements of this Part apply to the MODU of self-elevating and semi-submersible types, as well as to the fixed platforms including ice-resistant FOP and tension leg platforms.

1.1.2 The Rules for the Classification, Construction and Equipment of Mobile Offshore Drilling Units (MODU) and Fixed Offshore Platforms (FOP)¹ cover the accident situations of the following kinds:

- extreme hydrometeorological conditions;
- earthquakes;
- collisions with ships and other floating objects;
- helicopter accidents;
- dropped objects;
- explosions;
- fires;
- blowouts;
- combination of these;
- violation of safety requirements, incompetent management with the change of conditions, poor maintenance;
- other potential situations.

¹ Hereinafter referred to as "the MODU/FOP Rules".

1.2 DEFINITIONS AND EXPLANATIONS

1.2.1 The definitions and explanations relating to the general terminology are given in Part I "Classification".

1.2.2 In the present Part, the following definitions have been adopted.

Accident situation is an operational situation during which an accident may materialize.

Accident is an unintended event (occurrence) whose emergence is not expected in the course of platform normal functioning and which may cause substantial damages to a structure if it is not taken into account during design.

Safety is a property to retain a capability of performing specified functions under specified operational conditions through-out the specified time period wherein an impact of hazardous and harmful factors on the platform, its components, the environment and attending personnel is prevented or reduced down to tolerable values.

Error and fault tree is a graphic technique which permits to trace all the logical interconnections between technical faults, environmental conditions and human errors resulting in the event in question, and is a deductive method.

Event tree is a graphic technique ensuring a qualitative description of potential accident situations, as well as quantitative assessment for each tree branch, and is an inductive method.

Area of tolerable level of accident and their consequence risks is the materialization of an as low as reasonably practicable (ALARP) level.

Hazard identification is a process of identifying and recognizing an existing hazard, as well as a definition of hazard characteristics.

Individual risk (IR) is a risk (frequency of occurrence) of striking effects of a certain kind occurring during the materialization of certain hazards on a certain platform. It defines the distribution of risk.

Catastrophe is an extraordinary in its consequences event (accident) like a widespread disaster resulting in the platform loss, casualties or environmental damage.

FN curves present the level of an accident frequency plotted against the number of people killed in accident.

Hazard is a condition (natural or of the technosphere) wherein the phenomena or processes, which may strike people, cause a material damage or affect the environment, are likely to occur.

Risk is a frequency of hazards (of a certain class) materialization. The risk may be defined as a frequency or probability of event B initiating with the occurrence of an event A (a non-dimensional quantity ranging between 0 and 1).

Running a risk is an individual or a social group on whom the effect of a certain kind may be exerted during the materialization of a certain hazard or hazards, i.e. for whom the individual or societal risks are not null or, alternatively, reach a certain level.

Risk assessment is a process of hazards identification and risk evaluation as to the people, platform and environment. The risk assessment lies in the use of all available information for hazards identification and risk evaluation for a predetermined event (an accident and related situations) due to these hazards.

Societal risk is a function of risk (frequency of events occurrence) to strike the certain number of people exposed to striking effects of a certain kind during the materialization of certain hazards, of this number of people. It defines the extent of a catastrophic hazard for a platform.

Accident scenario is a complete and formalized description of the following events: an accident initiation phase, an accident process and emergency situation, losses in accident

including specified quantitative characteristics of accident events, their space-time parameters and causative links.

Operational standard is a document stating the functioning parameters required for the structure, systems, equipment, personnel and procedure for safety control.

AIR is annual individual risk.

QRA is quantitative assessment of risk.

"Continuously or frequently" is that an event happens continuously or may frequently happen during the service life of a given platform.

"Not frequently" is that an event may happen several times during the service life of a given platform.

"Infrequently" is that an event shall not happen during the service life of one platform, but it may happen on separate platforms of the same type during their service life.

"Very infrequently" is that an event shall not, but nevertheless may happen during the common service life of the certain number of the same type drilling platforms.

1.3 GENERAL PRINCIPLES OF PLATFORM SAFETY CONTROL

1.3.1 It is assumed that design, calculations, structure, platform operation and maintenance meet all the Register normative documents in force.

1.3.2 Safety assessment on the basis of a platform conceptual design shall be included in the general plan of design development and platform construction.

1.3.3 As a basis for safety assessment, a designer shall submit the following information:

description of the platform environment;

description of the platform functioning and operational details;

layout drawings showing arrangements and systems performing the most essential functions. Particular emphasis shall be placed on the locations wherein works are performed and the equipment, having a significant destructive potential, is installed, as well as on fire safety, accommodation complexes, escape routes, protective zones and evacuation systems;

key structural diagrams;

description of the most important measures provided for accident probability reduction;

description of measures provided for restriction of accident consequences;

description of escape routes;

description of the level of safety associated with new processes and technical innovations planned for use;

specified emergency cases corresponding to design emergency effects on platform parts specified in [Section 2](#);

calculation showing that the consequences of design extreme environmental conditions and emergency effects meet adequate safety criteria specified in [Section 5](#).

1.3.4 The assessment of platform safety shall, first of all, be conducted at the level of the design concept while selecting the platform type. It is assumed that the designer has selected the most favourable design decision, which meets the general principles of safety.

The meaning of this assessment shall make sure at the early design stage that the platform conception selected does not result in necessity to introduce principal alterations in design and construction due to the safety requirements. The objective of the safety assessment shall ensure acceptable safety in accordance with the set criteria.

1.3.5 The safety assessments regulated by the MODU/FOP Rules shall confirm the reasonably low probability of accidents evaluated by the use of annual individual risks, and also of societal risks (refer to [3.2](#) and [5.3](#)), of large losses (refer to [4.2](#)) and unacceptable environmental pollution that may happen as a result of the accident (refer to [Section 4](#)).

Supposedly, the platform that meets the assessments obtained in a conceptual design, and also the criteria of sufficient safety specified in the MODU/FOP Rules, will have the required safety level.

2 RISK IDENTIFICATION

2.1 CONCEPTION OF ACCIDENT SITUATION ANALYSIS

2.1.1 The analysis of accident situations falls into two main trends. The first one deals with the analysis of accident situations through conformity to standards (the MODU/FOP Rules, Guidelines on Technical Supervision of Mobile Offshore Drilling Units in Service, etc), and the second one, with the analysis of accident situations either for poorly studied scenarios or scenarios of a higher risk.

The analysis of an accident situation opportunity is an additional step destined for assessment of new and considerably different arrangements, equipment, processes, procedures and techniques whose nonconformity to standard practices may be significant. This analysis shall be used for definition and assessment of unexpected accident situations and unintentional actions, which may cause accidents.

The analysis of an accident situation opportunity consists in some measures to keep the platform accident probability and consequences to a minimum. The sequence of the measures is usually as follows:

- .1** determination of potential accident situations;
- .2** assessment of the risk level to be accepted;
- .3** prevention or elimination of accident situations.

The objective of the first and most important measure is the determination of accident situation types (refer to [2.2](#)); of the second measure, the evaluation of the risk of an identified accident situation for the personnel, platform and environment (refer to [2.3](#), [3.1](#) and [3.2](#)); and of the third one, the elimination or prevention of an accident when the risk level was recognized as unacceptable (refer to [Sections 4](#) and [5](#)).

2.2 TYPES OF ACCIDENT SITUATIONS ON PLATFORMS

2.2.1 General.

2.2.1.1 The analysis of accident situations is performed regularly to identify, evaluate and control potential accident situations on platforms. The thorough and precise assessment of potential accidents on platforms will keep to minimum personnel injuries, equipment losses and environmental threats.

Taken alone, the analysis of accident situations does not ensure the proper level of safety on a platform. It is only the part of a general safety system. Other areas relating to this system are industrial safety, personnel training and a response to accidents.

The analysis of accident situations is used in design (since a design concept), construction and operation of a platform. In this case, all the design modes of operation shall be considered: transit, positioning at a site, operational mode, survival or extreme loading, removal from site, etc.

The analysis of accident situations shall be also applied to existing platforms if they are subjected to major modifications.

2.2.1.2 The general trend of the accident situation analysis is the desire to define the potential hazards associated with development of the accident situation, and the actions on detailed assessment of risk related to an accident. Most of these techniques are complicated, expensive and take a good deal of time, but they may be justified by the safety level and accident consequences.

2.2.1.3 The analysis of potential accident situations shall be approved by the Register and shall include the following:

.1 description of conditions at the beginning of an accident situation, initial data for analysis;

.2 description of measures to fight accidents, platform equipment and systems specified for mitigating accident consequences;

.3 information on analysis techniques, physical and statistical models;

.4 description of the accident development process including its design presentation;

.5 protective measures for personnel and individuals present on board a platform in accident.

2.2.2 Potential accident situations for all MODU/FOP.

2.2.2.1 In extreme environmental conditions:

various structural faults in working position due to unintended development of events;
shifting, capsizing and setting of a platform on the seabed under the unfavourable combination of environmental conditions and soil properties changed;

transportation of the platform in conditions that do not correspond to acceptable ones by strength criteria and structures reliability;

significant fatigue damages due to severe sea, wind, ice and seismic effects;

brittle fractures in low temperatures and pulse loads.

2.2.2.2 In collision with a ship or floating object.

The process of formation of the ship and platform interaction force in collision is described by the formula

$$N = N_s + N_d \quad (2.2.2.2-1)$$

where N = total effect;
 N_s = static force (running aboard);
 N_d = dynamic force (impact);

$$N_d = M\ddot{X} + B\dot{X}$$

where M and B = inertia and damping factors in collision with a ship, respectively;
 \ddot{X} , \dot{X} = acceleration and speed of a ship relative to a platform recorded at the instant of collision.

An impact momentum, if the additional requirements are not specified, is the following:

$$N_d \Delta t = M \dot{X} \quad (2.2.2.2-2)$$

where Δt = collision time that depends on the extent and effectiveness of collision objects protection against an impact.

Two types of collision shall be considered:

running aboard of a ship or floating object, i.e. the touch of a platform external surface by a ship or floating object at low speed, usually $\leq 0,3$ knots; the factors on the speed and inertia components of the impact are negligible (an impact momentum is nil); the effect may be considered as generated by the impressed force applied statically;

collision with a ship or floating object i.e. the impact of a ship or floating object on a platform external surface; the factors on the speed and inertia components of the effect are sufficient to generate an impact momentum.

2.2.2.3 With explosions, dropping and flying object

2.2.2.3.1 The main external and internal sources associated with the effect of explosions, dropping and flying objects (fragments) on a platform are:

a helicopter accident;

accidents on supply ships and tankers nearby a platform resulting in explosions and/or emergence of flying objects;

pressurized vessels (bottles) and pipelines containing gas or liquid explosive media;

structures and equipment having significant potential energy.

2.2.2.3.2 A flying (dropping) object exerts a mechanical effect on an object (structure, equipment and personnel). The extent of its hazard (striking effect) is primarily defined by the object mass and rate of fall. In addition, the striking effect of the flying object depends on its shape, an angle between a velocity vector direction and an impact plane, etc.

The effect of an explosion on the object is caused by the quick change of an excess air pressure, particularly, in the form of an air shock wave. The level of an air explosion hazard is characterized by the value of the maximum excess pressure. However, in order to assess the object response to an explosion effect, the time of excess pressure build-up and fall shall be determined. The destruction (failure) of some potential explosion sources may be accompanied by simultaneous formation of an excess air pressure and generation of flying objects (fragments). For instance, it takes place in explosion failure of pressurized vessels (bottles).

A helicopter accident along with the mechanical (impact) effect of a fuselage (or other helicopter parts) on platform structures and equipment may be accompanied by an explosion of fuel vapours. Account shall be taken of the explosion possibility both outside and inside platform spaces. The internal explosion usually results in a significantly larger scale accident.

2.2.2.3.3 The possible primary effects (factors) associated with an explosion, dropping (flying) objects and a helicopter accident:

deformation, damage, destruction of structures and equipment;

injuries and fatalities among personnel;

motion (shaking) of structures;

generation of flying objects;

emergence of caustic toxic gases and aerosols;

fire.

The primary effects, in its turn, may give rise to the new set of similar secondary factors. Thus, for instance, shaking of structures may cause equipment damaged, unsecured objects fall, personnel injuries due to falls, etc;

2.2.2.3.4 Three levels of an explosion and flying (dropping) object hazard are set:

I – features the maximum possible values of striking factor parameters and characteristics for a given source;

II – features the values of striking factor parameters and characteristics not relating to the levels I and III;

III – features the values of striking factor parameters and characteristics which do not cause appreciable consequences for platform structure, equipment and personnel and, therefore, for the natural environment as well.

Where the values of striking factor parameters and characteristics for a given source cannot be determined with the adequate degree of reliability, a conservative approach for safety assessment shall be used assuming that the level I hazard is materialized.

2.2.2.3.5 The level III hazard is defined by tolerable levels of loadings on structures, equipment and personnel.

The following loading levels on personnel may be accepted as tolerable¹:

tolerable levels of accelerations (for sitting and standing positions) – 0,9g (along all the coordinate axes);

at the impact of a head against an obstacle, the collision velocity is not to exceed 2,3 m/s;

at impacts by objects having a mass of 1, 2, 3, 4 and 5 kg the impact velocity shall not exceed 5; 3,7; 3; 2,5 and 2,2 m/s, respectively;

the value of an excess pressure of a shock wave shall not exceed 35 kPa.

2.2.2.4 In fires and blowouts.

2.2.2.4.1 Fires on MODU/FOP are in principle subdivided into two categories:

on the exposed deck caused by an oil and/or gases blowout from a well; in internal spaces.

2.2.2.4.2 To identify fire risk, MODU/FOP depending on the functions performed (what defines the potential level of a structure hazard) are subdivided into three groups:

oil storage platform;

production platform;

exploratory drilling unit.

Considering [2.2.2.4.1](#) the qualitative risk matrix shown in [Fig. 2.2.2.4.2](#) may be recommended for use accordingly.

¹ Refer to Federal rules and regulators in the field of Atomic Energy r-05-035-54 "Integration of external influences of natural and technogenetic origin on nuclear and radiation hazardous objects".

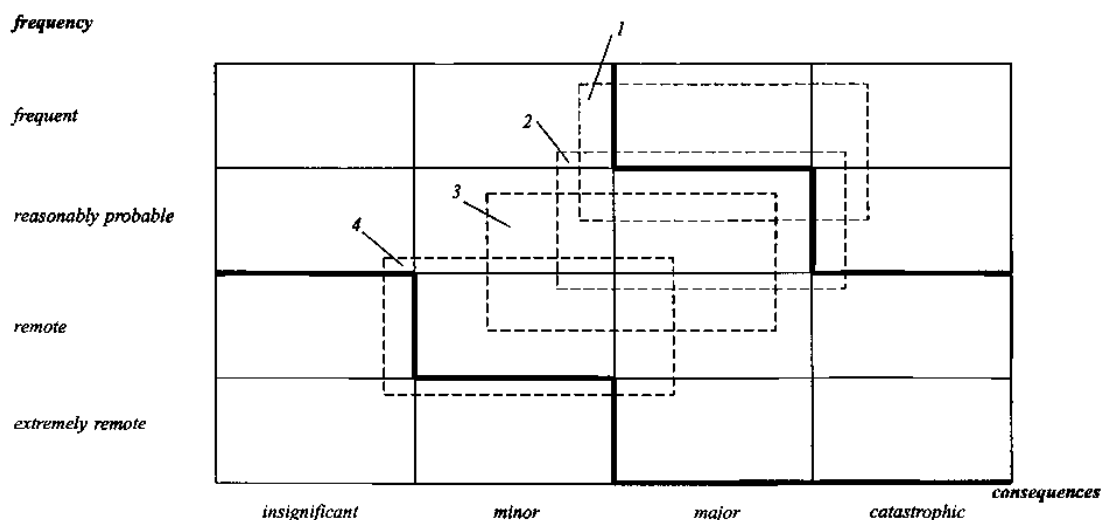

Fig. 2.2.2.4.2
Qualitative risk matrix in fire:

- 1 – fires on an oil storage platform due to an oil blowout;
- 2 – fires on a production platform due to an oil blowout;
- 3 – fires on a MODU due to an oil blowout;
- 4 – fires in internal spaces

2.2.2.4.3 A fire on an exposed deck caused by an oil and/or gases blowout from a well shall be classified as the most hazardous (refer to [Fig. 2.2.2.4.2](#)). The particular hazard of this fire is that firstly, the oil spread covers a large area; secondly, the influx of a combustible liquid and/or gas is reasonably large and practically uncontrollable, at the initial stage of the fire in particular; thirdly, in the air above the unit a gaseous combustible mixture is formed which consists of air, gases coming from a well and oil vapours as well.

The sources of such combustible mixture ignition may be:

- faulty deck lighting;
- open flame;
- sparks of any origin;
- exhaust combustible gases;
- combustible parts of equipment.

This fire may follow various scenarios and a sufficient number of various factors may affect fire propagation. In relation to the above, in order to assess risk in fire, logic diagrams of accident development shall be used basing, for example, on constructing event trees. In constructing the logic diagram the following shall be considered first:

- level of a structure hazard (refer to [2.2.2.4.2](#));
- chemical composition of potentially ignitable substance (oil/gas-condensate);
- environmental conditions of an operating area (first of all, wind);
- actual capabilities of killing a well;
- presence of other structures (primarily, permanently manned) near the platform;
- possibility of a follow-up explosion;
- technical condition of the MODU/FOP hull;
- effectiveness of fire protection functioning etc.

It shall be also taken into account that a given fire may cause an oil spill fire and a fireball. Regarding an effect on a human, the striking factors like direct fire effect, excess pressure and heat emission shall be considered.

2.2.2.4.4 Fires in MODU/FOP internal spaces may be divided into three main groups:
fires in energy compartments (except purely electrical compartments and spaces);
fires of electrical equipment;
fires in service and accommodation spaces.

The main reasons of fire emergence in internal spaces are:
violation of operating conditions and regulations for equipment and devices operation;
accidents and failures of equipment, machines, machinery and devices, as well as of their service systems.

The source of fire emergence in internal spaces may be:

sparks of any origin;
open flame;
surfaces heated up to a temperature of fuels and lubricants ignition (uninsulated parts of gas exhaust, overheated bearings, electrical equipment);
faulty electric wiring.

2.2.3 Specific accident situations for platform.

2.2.3.1 Self-elevating MODU.

2.2.3.1.1 All types of accident situations according to [2.2.2](#) may be materialized with regard to self-elevating MODU.

2.2.3.1.2 Specific potential accident situations for self-elevating MODU may be:
subsidence of legs during embedding into the seabed;
jamming of a jacking system during platform hull elevation into an operating position;
scouring of the seabed by bottom currents;
fluidization of the seabed under changing loads;
capsizing and shifting of the platform, as well as the subsidence of legs under wind and wave loads, and as the result of the impact of a ship or other floating object on the leg;
cockings and the break of integrity of the legs when pulled out from the seabed;
sliding apart of the legs in the soil under the unfavourable combination of external loads and the peculiarities of seabed response;
catastrophic consequences of damage to one of the legs of a three-leg unit;
gas blowouts accompanied by a spring in way of the legs;
seizure of the platform hull midway of elevation or lowering on the legs;
failure of elevation machinery;
damage to structural elements of the legs due to collision with a ship or other floating object;
catastrophic consequences, as the result of an earthquake, in connection with changed properties of the base.

2.2.3.2 Semi-submersible MODU.

2.2.3.2.1 All the types of accident situations according to [2.2.2](#) may be materialized with regard to semi-submersible MODU. The specific feature of these units is that the accident situations associated with earthquakes are not applied to them.

2.2.3.2.2 Specific potential accident situations for semi-submersible MODU may be:
damages (residual deformations, break of integrity) to structural elements of pontoons, stability columns, bracings, upper hull and their joints;
floating of a void compartment;
leakage of oil products;
inclination of the semi-submersible MODU hull;
breakage of anchor chains;
combination of the above accident situations.

2.2.3.3 Fixed offshore platform (FOP).

2.2.3.3.1 All the types of accident situations according to [2.2.2](#) may be materialized with regard to FOP.

2.2.3.3.2 Depending on the architectonic-constructive type of the FOP, specific potential accident situations for them may be:

- damages (residual deformations, break of integrity) to structural elements of the hull;
- leakage of oil products;
- scouring of the seabed by bottom currents;
- fluidization of the seabed under changing loads;
- shifting of the structure;
- capsizing of the structure;
- subsidence of the structure at large or its individual parts;
- crawling of the ship's end onto the platform inclined side;
- collision of the FOP operating in the northern area with an iceberg or grounded ice;
- combination of the above accident situations;
- loss of stability on the seabed as the result of an earthquake.

2.3 ACCIDENT SITUATION ANALYSIS TECHNIQUES

2.3.1 Checklist.

Use of checklist is a usual method for identification of compliance with standards. The exemplary checklist for the analysis of an accident situation on a mobile offshore drilling unit is given in [Appendix 1](#).

The checklist is simple for use and may find application during design, construction, operation and an accident situation. The minimum acceptable level of hazard is determined with the help of the checklist.

Where necessary, checklists may be drawn up for specific situations and used for assessment of proper execution of standard production operations and for specifying the problems to be emphasized.

The checklist is the most quick and simple method for analysis of an accident situation and very effective in the process of standard accident situations management.

2.3.2 "What if... " analysis.

This method is much like the one of checklists use. The method is based on the questions, which begin with "What if... " and considers situation development after "What if... ". The compilers of the analysis shall be very cautious and adequately realistic so as not to think of improbable schemes of events development.

The "What if... " type analysis may be used during design, modification or operation of a drilling platform. Its result is the list of problem locations potential for accidents and the methods supposed for accidents avoidance and prevention.

2.3.3 Hazard identification (HAZID) study.

A multidisciplinary team shall take part in these studies which define accident situations and platform operability using the structural form of the "What if... " type analysis.

The constructive decision on each component of a process scheme is analyzed in the form in which it is presented in design documentation.

The HAZID method may be used during design, modification and operation of a platform. The result of the analysis is the list of problems associated with potential accidents or reduction in platform operability, as well as the types of malfunctions and consequences of each one.

2.3.4 Event tree analysis.

The event tree analysis is an inductive method intended for a study of accident roots and identification of key errors that initiated the accident. It also provides analysis with the base for accident risk definition.

The event tree analysis consists in constructing the sequence of events (tree branches) causing the top event (event at the top of a tree). Some examples of event trees are given in [Appendix 2](#).

This method is used during design, modification and operation of a platform. It is particularly useful in analysis of new technologies, structural decisions and operational conditions, which have not passed an evaluation test in practice yet. The method ensures:

- qualitative description of potential problems including potential event combinations;
- quantitative assessments of events frequency for each tree branch which allow to determine the contribution of each event to risk assessment.

2.3.5 Error chain (fault tree) analysis.

A fault tree analysis is a deductive method that focuses on a particular event resulting in an accident, which is called the top event, and on the construction of the logic diagram of all the relationships that may cause this event. The error chain is a graphical illustration of various structural faults, equipment malfunctions, the effect of environmental conditions and human errors, which may cause an accident.

Some examples of error and fault trees are given in [Appendix 3](#).

2.3.6 Hazard and operability (HAZOP) study.

This method may be used during platform design, modification and operation. These studies result in the list of problems, which may cause a potential accident, or reduction of platform operability, as well as in the list of recommended changes, proposals or actions aimed at safety or operability improvement. This method time and effectiveness directly depend on the platform size and complexity and on expertise of specialists who define accident situations and platform operability using the structural form of the "What if... " analysis (refer to [2.3.2](#)).

2.3.7 Failure mode and effects analysis (FMEA).

This analysis is used in definition of individual types of faults, which may cause or contribute to accident occurrence. The analysis of the type of faults and of their consequences may be used along with other ways of hazard identification, such as described in [2.3.5](#).

The purpose of this analysis is the definition of fault types and of each fault consequences for a platform. At the design stage, this method may be used for identification of needs in additional protective measures or in their reduction. The fault analysis during platform modification is used for definition of its impact on existing structures and equipment. This method is also used in operation for definition of individual faults that may result in significant consequences.

So far as this method is subjective, at least two specialists competent in processes and equipment are needed for its use.

Where each type of faults is included in the analysis of a criticality level, the method goes over into a critical analysis of types of faults and of their consequences.

3 METHODS OF QUANTITATIVE RISK ASSESSMENT (QRA)

3.1 STATISTICAL MODELS OF ACCIDENT SITUATIONS

3.1.1 The purpose of risk assessment is to focus attention on areas of the highest risk levels, and also to identify factors having an important effect on them. In addition, the purpose of risk assessment is the establishment of a relationship between the IMO regimes and accident consequences to provide a possibility for introducing regulatory changes for risk reduction.

3.1.2 Among accident situations under consideration shall be those, which allow identifying different types of risks (to people, the environment, structures and equipment).

3.1.3 The purposes of risk assessment stated in [3.1.1](#) can be achieved, firstly, by constructing so-called event trees (refer to [2.3.4](#)) and fault trees (refer to [2.3.5](#)). In addition, other appropriate methods (refer to [2.3](#)) may be used.

3.1.4 The quantitative assessment of contributions to risks is typically undertaken in three stages using available accident statistics:

the categories and sub-categories of accident are quantified in terms of their recurrence (frequency);

the magnitude of accident outcomes is quantified in risk terms;

the distribution of outcome magnitudes across all the sub-categories of accidents is determined in risk terms, so as to evaluate which sub-categories contribute how much risk.

3.1.5 The mathematical technology of QRA may comprise different statistical models including the Bayesian statistics, Monte Carlo method, composite probability formula and other adequate statistical techniques.

For example, the composite probability formula in determination of QR_kA is written down as follows:

$$QR_kA = \sum_{i=1}^{i=n} Q_i Q_{ik} \quad (3.1.5)$$

where Q_i = recurrence of the i -th situation (accident event) under consideration;
 Q_{ik} = risk of an accident (as example, a probability of materialization for the i -th branch of an event tree if the method specified in [2.3.4](#) is used);
 n = number of scenarios (events) being considered for the given kind of an accident (or the number of event tree branches);
 k = consistent with the given kind of an accident.

3.1.6 The statistical models corresponding to the description of platforms responses to environmental effects (wind, sea, currents, ice, seismic effects) shall not contradict those used in the MODU/FOP Rules.

3.1.7 Impact diagram.

An impact diagram is most commonly used for comparison of some versions of a solution. Emphasis shall be placed on the higher risk area. In these cases, the diagram that materializes the proposal based in a table-matrix, may be applied.

Both quantitative and qualitative results can be obtained on the basis of [Table 3.1.7](#).

3.1.8 The risk assessment results in:

identification of high risk areas;

re-evaluation of risk for each risk control option identified in the following third step of formal safety assessment (refer to [Section 4](#)).

Table 3.1.7

Type risk matrix¹

Frequent	8	9	10	11
Reasonably probable	6	7	8	9
Remote	4	5	6	7
Extremely remote	2	3	4	5
↑ frequency consequences →	Insignificant	Minor	Major	Catastrophic

¹ Terms are defined in [5.2](#).

3.2 EVALUATION OF INDIVIDUAL AND SOCIETAL RISKS

3.2.1 In the analysis of accident situations, the individual risks featuring the frequency of emergence of striking effects of a certain kind are determined.

The value of an annual individual risk AIR_k at any effect or an accident event is determined by the formula

$$AIR_k = \sum_{i=1}^{i=n} Q_i Q_{ik} Q_{ik}^p \quad (3.2.1)$$

where $Q_i Q_{ik}$, and n = refer to [3.1.5](#);
 Q_{ik}^p = conditional probability to affect people in materialization of the i -th branch of an event tree.

3.2.2 Evaluation of individual risk for the FOP working spaces and storage areas.

3.2.2.1 The design individual risk (IR) per annum Q_{IR} for hazardous spaces of category A and B shall be calculated by the formula

$$Q_{IR} = Q_{EXPL} Q_{PR} \quad (3.2.2.1)$$

where Q_{EXPL} = probability of explosion in a space during a year;
 Q_{PR} = probability of presence of people in a space (in case of permanent watch in a space $P_{PR} = 1$).

3.2.2.2 Probability of explosion in a space Q_{EXPL} shall be calculated on the basis of statistical data according to the formula

$$Q_{EXPL} = Q_{comb} Q_{IGN} \quad (3.2.2.2)$$

where Q_{comb} = probability of origination of explosive gas-vapour mixture in a space during a year;
 Q_{IGN} = probability of leak's ignition.

3.2.2.3 Probability of explosion in a space Q_{EXPL} may be calculated on the basis of analysis of event tree by the formula

$$Q_{EXPL} = Q_G Q_{LFL} Q_{Gign} Q_{ACS} \quad (3.2.2.3)$$

where Q_G = probability of origination of explosive gas-vapour mixture in a space;
 Q_{LFL} = probability of absence of ventilation and reach of concentration exceeding lower flammable limit (LFL) (probability of failure of the main and emergency ventilation is taken $Q_{LFL} = 0,1$ - for instance, in case of absence of power supply);
 Q_{Gign} = probability of ignition of explosive gas vapour mixture;
 Q_{ACS} = probability of failure of process automated control system (ACS) (explosive concentration sensors, shutoff valves etc.).

3.2.3 Evaluation of individual risk for personnel in the area effected by striking factors during fire/ explosion on the external installations.

3.2.3.1 The value of individual risk R_{IR} for external installations during burning of gas-, vapour or dust air mixtures shall be calculated by the formula

$$R_{IR} = \sum_{i=1}^n Q_{fi} Q_{p in j} \quad (3.2.3.1)$$

where Q_{fi} = annual i -accident condition frequency involving burning of gas-, vapour- or dust air mixture on the external equipment in question, year⁻¹;

$Q_{p\ inj}$ = conditional probability of a person injury by excessive pressure at a given distance from external installations if the said accident of i -th type comes true;
 n = number of types of accidents in question.

3.2.3.2 The value of individual risk R_{IR} at possible burning of substances and materials shall be calculated by the formula

$$R_{IR} = \sum_{i=1}^n Q_{fi} Q_{f\ ing\ i}, \quad (3.2.3.2)$$

where Q_{fi} = annual frequency of fire occurrence on the external installations in question in case of accident of i -th type, year⁻¹;
 $Q_{f\ ing\ i}$ = conditional probability of injury to person located at a given distance from the outer equipment by thermal emission if accident of i -th type comes true;
 n = number of types of accidents in question.

The value of Q_{fi} shall be based on the statistical data or methodologies set forth in normative documents approved in due order.

It is allowed to consider only one adverse accident which value Q_f is taken equal to the annual frequency of occurrence of fire on the external installations according to normative documents approved in due order and the value of $Q_{f\ ing\ i}$ is calculated on the basis of the mass of combustibles emitted to atmosphere.

3.2.3.3 Conditional probability $Q_{p\ inj}$ of damage to a person by excessive pressure at burning of gas-, vapour - or dust air mixture at a distance r from the epicentre shall be calculated as follows:

excessive pressure ΔP and impulse i is calculated according to methods described in the Fire Code Standards 105-03;

based on values of ΔP and i , the value of "probit" of the function of P_r is calculated by the formula

$$P_r = 5 - 0,26 \ln(V) \quad (3.2.3.3)$$

where $V = (17500/\Delta P)^{8,4} + (290/i)^{9,3}$;

ΔP = excessive pressure, Pa;
 i = pressure wave impulse, Pa·s.

After that the conditional probability of injury to person shall be defined (refer to using [table 3.2.3.5](#)). For instance, at a value $P_r = 2,95$ the value of $Q_{p\ inj} = 2\% = 0,02$, while at $P_r = 8,09$ the value of $Q_{p\ inj} = 99,9\% = 0,999$.

Herein, for the MODU/FOP personnel the education and training coefficient of personnel shall be taken equal to 0,7 (i.e. the value $Q_{p\ inj}$ is multiplied by 0,7).

3.2.3.4 When calculating the probability of injury to the people directly related to the accidents the following general provisions shall be used:

due to uncertain conditions of the people injured in the enclosed spaces of ice-resistant MODU/FOP, the number of those suffered shall be evaluated with no distinction of the dead and injured;

when evaluating the number of suffered people, there shall be considered only the primary losses at the moment of the accident and the subsequent initial period of its development;

any possible losses in the rescue teams participating in localization and liquidation of the accident consequences shall not be taken into account;

it is assumed that personnel shall perform all actions prescribed by safety rules in accordance with warnings and alarms (quitting working places in hazardous areas, use of collective and individual protective means).

3.2.3.5 The conditional probability of injury of person $Q_{f inj i}$ by heat emission shall be calculated as follows:

.1 calculate the value of R_r by the following formula:

$$R_r = -14,9 + 2,56 \ln(tq^{1,33}) \quad (3.2.3.5.1)$$

where t = effective time of exposition, s;
 q = intensity of heat emission, kW/m², calculated in accordance with the method of calculation of heat emission for various categories of spaces and external installations;

.2 value of t .
for fires, spills of highly flammable liquid, combustible fluids and solid materials

$$t = t_0 + x/v \quad (3.2.3.5.2)$$

where t_0 = characteristic time of fire detection, s, (it shall be not more than $t = 5$ s);
 x = the distance from the location of the person to the area where intensity of heat emission doesn't exceed 4 kW/m², m;
 v = the velocity of a person, m/s (it should be not more than $v = 5$ m/s);

.3 for the impact of "fireball" t shall be calculated in accordance with the method of calculation of the heat emission intensity;

.4 the conditional probability $Q_{inj i}$, of a person injury by heat emission shall be determined according to [Table 3.2.3.5](#).

Herein, the coefficient of training and education of MODU/FOP personnel shall be equal to 0,7 (i.e. conditional probability Q_i of a person injury by heat emission is multiplied by 0,7).

If both spillage fire and "fireball" are possible at the technological installations in question then both types of accidents shall be considered.

Table 3.2.3.5

The amount of conditional probability of a person's injury depending on the value of R_r

Injury conditional probability, %	R_r value									
	0	1	2	3	4	5	6	7	8	9
0	–	2,67	2,95	3,12	3,25	3,36	3,45	3,52	3,59	3,66
10	3,72	3,77	3,82	3,90	3,92	3,96	4,01	4,05	4,08	4,12
20	4,16	4,19	4,23	4,26	4,29	4,33	4,36	4,39	4,42	4,45
30	4,48	4,50	4,53	4,56	4,59	4,61	4,64	4,67	4,69	4,72
40	4,75	4,77	4,80	4,82	4,85	4,87	4,90	4,92	4,95	4,97
50	5,00	5,03	5,05	5,08	5,10	5,13	5,15	5,18	5,20	5,23
60	5,25	5,28	5,31	5,33	5,36	5,39	5,41	5,44	5,47	5,50
70	5,52	5,55	5,58	5,61	5,64	5,67	5,71	5,74	5,77	5,81
80	5,84	5,88	5,92	5,95	5,99	6,04	6,08	6,13	6,18	6,23
90	6,28	6,34	6,41	6,48	6,55	6,64	6,75	6,88	7,05	7,33
–	0,00	0,10	0,20	0,30	0,40	0,50	0,60	0,70	0,80	0,90
99	7,33	7,37	7,41	7,46	7,51	7,58	7,65	7,75	7,88	8,09

3.2.3.6 If it is impossible to evaluate the probability of the people injury under various scenarios of accidents the following provisions shall be undertaken:

3.2.3.6.1 For the jet fires:

All personnel in the immediate vicinity of the area of burning gas leaks shall be exposed to the high level of heat emission inherent to jet fires. For the purpose of risk analysis the following possible consequences shall be considered:

minor leaks with the early ignition which do not lead to death;

average leaks with the early ignition cause death of up to 25 per cent employees located in the area of accident;

large leaks with the early ignition cause death of up to 50 per cent employees in the immediate vicinity of the area of accident.

Considering that the accidents escalate after long exposure of fire bulkheads and decks to jet fires it is accepted that such cases do not cause fatality.

3.2.3.6.2 For areal burning (at pool fires):

All personnel in the immediate vicinity of the area of a fire spill is affected by the smoke and high level of heat emission inherent to fires. The following possible consequences shall be considered:

minor spills with the early ignition which do not cause death;

average spills with the early ignition which cause death of up to 5 per cent employees in the immediate vicinity of the area of accident;

large spills with the early ignition which cause death of up to 10 per cent employees in the immediate vicinity of the area of accident.

Considering that the accidents escalate after long exposure of fire bulkheads and decks to areal fires it is accepted that such cases do not cause death.

3.2.3.6.3 For explosions:

for the purpose of this evaluation the probability of explosion is related to deferred ignition of gas cloud in the closed area, and the time of delay depends on the spillage intensity. Although in all cases the personnel has an opportunity to leave the area of accident by the time of ignition of spills, however, possible errors and other related circumstances may cause direct fatalities due to impact stresses which are taken equal to 10 per cent for average spills and 25 per cent for large spills.

3.2.4 The value of the total annual individual risk AIR_{Σ} at various effects (e.g. due to an earthquake, fire, explosions, dropped objects, etc.) is determined as the sum of AIR for separate effects, i.e.:

$$AIR_{\Sigma} = \sum_{k=1}^{k=m} AIR_k \quad (3.2.4)$$

where m = number of potential striking factors taken into account.

3.2.5 Societal risk is evaluated with use of FN curves connecting the level of an accident frequency (F) with the number of people killed in accident (N).

The societal risk assesses the magnitude of potential catastrophes. It is an integral characteristic of the materialization of certain kind consequences. The value of the societal risk (i.e. fatality risk) at $N = 1$ is used for determining the annual individual risk. The example of FN curves construction is given in [Appendix 4](#).

3.2.6 The average acceptable cost of a reasonable life losing magnitude shall be calculated by the formula

$$R_A = qE$$

where q = adduced indicator of average fatalities to Gross Domestic Product (GDP), in dollar measurement billion US dollars.

It is recommended to calculate the average acceptable value, corresponding to point on curve FN (frequency of cases with one or more fatalities), according to the formula

$$F_1 = qE / \sum_{N=1}^{N_u} \frac{1}{N}$$

where N_u = upper limit of the number of fatalities which may occur during one accident. For the accidents which do not involve the third party, this upper limit shall reach the total number of crew and probably other persons onboard.

ALARP zone may be based around this value provided risks are inadmissible if they are one order of the value of acceptable average bigger and negligible if they are one order lower of this value.

3.3 RECOMMENDATIONS ON EVALUATION OF CATASTROPHE RISK AFTER STRUCTURE DAMAGE

3.3.1 These recommendations shall be considered as an addition to the analysis of an accident risk (refer to [3.1](#)). Preference shall be given to the accident events that may result in catastrophic consequences (refer to [5.2](#)).

The recommendations may be used for analysis of already happened events to accumulate experience, during platform operation, as well as in design as a forecast.

3.3.2 A catastrophe risk CR may be determined by the formula

$$CR = CR_1 + (1 - CR_1)CR_2 \quad (3.3.2-1)$$

where CR_1 = accident risk (corresponds to Q_{ik} in [3.1.5](#) if the risk of the accident consequences CR_2 in accordance with the recommendations of [3.3.4](#) is not taken into account in this quantity);
 CR_2 = accident consequences risk determined on the basis of the recommendations stated below.

In determination of quantitative catastrophe characteristics QRA_k (refer to [3.1.5](#)) and AIR_k (refer to [3.2.1](#)) it shall be assumed

$$Q_{ik} = CR. \quad (3.3.2-2)$$

3.3.3 The algorithm is constructed as follows: it is assumed that an accident has happened, a structure has suffered a damage (damages) and further, the consequences of this damages are analyzed. The algorithm is based on structural adequacy (refer to [4.1.6](#)) because the loss of the structure will eventually result in fatalities and damage to the environment.

3.3.4 In evaluation of damage consequences, the following problems are recommended for consideration.

3.3.4.1 Damage identification.

At this point, the question shall be answered: has the given damage been taken into account during platform design (i.e. to what extent it complies with the design damage). In practice, it is precisely design damages that are quite difficult to materialize. Some deviations will always take place.

Working the problem, at least the following questions shall be answered:

were the direct calculations of damaged structure strength performed during platform design and which damage versions were considered;

which margin of survivability (in terms of structural redundancy) has the structure.

3.3.4.2 Evaluation of technical condition of a structure as a whole.

The key question: how much did the technical condition of a structure meet the requirements of normative documents prior to suffering a damage (practically, a moment before suffering a damage). The actual technical condition of the offshore platform hull may adversely effect damage spread as well.

Answering this question, the following shall be known:

age of an offshore platform;

is an active system for evaluation of and watch on structure behaviour available on the platform (monitoring of cracks, deformations, etc.);

date of the last survey or inspection for defects of the platform hull conducted, survey (inspection) results: residual thicknesses, residual deformations, cracks, fractures, presence of obviously weakened zones and in the damage area in particular;

was any deviation from the requirements of normative documents allowed in assessment of residual thickness and deformation values (if so, how much are deviation data justified?);

was the repair of structural elements conducted; repair quality;

what time was offshore platform service prolonged for after a survey.

3.3.4.3 Evaluation of environmental conditions.

The key question: will external loads (sea, ice, other environmental loads) exceed or not exceed the design ones for a damaged platform. The case in point is the platform life time after the damage.

Working the problem, the following is worth to regard:

period of the year when a damage has occurred because the probability to exceed the design value of a load changes within a year;

time period needed for taking measures to prevent a potential catastrophe;

is an active system for evaluation of environmental conditions (wind sea, ice, seismic effects, etc.) available on the platform.

In the final, a realistic forecast of environmental conditions shall be available.

3.3.4.4 Evaluation of the possibility of a failure for systems and arrangements such as: anchor lines, a dynamic positioning system, etc. This problem is particularly topical for mobile offshore platforms, and also for platforms in transit conditions.

Working the problem, it is worth to have the following information on:

actual technical condition of systems or arrangements;

environmental conditions after platform structure damage.

The solution of problem [3.3.4.4](#) is associated with that of the [3.3.4.3](#) problem with regard to evaluation of environmental conditions.

3.3.4.5 Evaluation of the possibility to damage other elements of the platform hull.

The solution of this problem is associated with that of the problems [3.3.4.1](#) (as far as structural redundancy is materialized in platform design), [3.3.4.2](#) (technical condition of structural elements within a damage area and zones of potential emergence of other damages) and [3.3.4.3](#) (as far as is realistic to exceed design environmental conditions).

3.3.5 The materialization of the algorithm on assessment of damage consequences may be carried out by construction of an event tree. The event tree, recommended as the type one, is presented in [Table 3.3.5](#). Items 1, 2, 3, 4 and 5 of the event tree correspond to the key problems defined in [3.3.4.1 to 3.3.4.5](#).

Table 3.3.5

Type event tree for assessment of platform post-damage consequences

Can the given damage be identified as taken into account (as design) in platform hull design?	Did the technical condition of the structure as a whole meet normative documents?	Will the accepted environmental conditions (loads) for a damaged platform be exceeded?	Will it be possible to fail for systems and arrangements like anchor lines, dynamic positioning systems, etc.?	Will the damages of other elements of the platform hull be possible?	Combined probability: Yes – minimum accident consequences, No – accident
consequences risk	1	2	3	4	5
<p style="text-align: center;"><i>Accident consequences risk = (2)+(3)+(4)+(5)+(6)</i></p>					

3.3.6 Working out the algorithm on assessment of damage consequences, available experience of offshore platform design and operation has been taken into account. Further accumulation of the experience shall facilitate algorithm development.

3.4 EXPERT ANALYSIS TECHNIQUES

3.4.1 Delphi technique.

Using the Delphi technique, an "informed intuitive judgement" is materialized, and for this: a problem is formulated; a team of experts, who can comprehensively cover the formulated problem, is selected; the conditions enabling the most effective work of the team of experts are created, and the team is headed by an experienced analyst who is well aware of the Delphi technique; all the team members are provided with the information available on the problem in question.

The sequence of conditions in use of the Delphi technique is organized as follows:

- .1 a leading analyst or someone else on his behalf prepares the initial information on the problem which is presented to the team of selected experts in writing or orally, or in both ways if necessary;
- .2 the experts deliver their judgement evaluated either by ranking of versions proposed (if quantitative assessments are impracticable) or by quantitative assessments of the event in question (if possible);
- .3 opinions received from the individual experts guided by the analyst are compared and comments of each expert are discussed;
- .4 the experts re-evaluate their initial judgements if, from their standpoint, there are prerequisites for this;
- .5 the final result of assessment is drawn up.

3.4.2 Coefficient of concordance.

The extent of experts team consent is evaluated using a coefficient of concordance W

$$W = \frac{12 \cdot \sum_{i=1}^{i=n} \left\{ \sum_{j=1}^{j=n} x_{ij} - \frac{1}{2} m \cdot (n+1) \right\}^2}{m^2 (n^3 - n)} \quad (3.4.2-1)$$

where m = number of experts;
 n = number of objects.

The coefficient W varies from 0 to 1. $W = 0$ means that no linkage exists between experts rankings, while $W = 1$ means that all experts rank objects for a given attribute in the same way. The estimate of concordance coefficient significance is defined using a parameter Z

$$Z = \frac{1}{2} \ln \frac{(m-1)W}{1-W} \quad (3.4.2-2)$$

which has a Fisher distribution with degrees of freedom

$$v_1 = n - 1 - \frac{2}{m} \text{ and } v_2 = (m - 1)v_1$$

A Pearson χ^2 criterion may be used for the quantity $n > 7$. The quantity $m(n-1)W$ has a χ^2 distribution with $v = n - 1$ degrees of freedom.

If the objects ranking by this attribute has the tied ranks the concordance coefficient W shall be calculated by the formula

$$W = \frac{\sum_{i=1}^{i=n} \left[\sum_{j=1}^{j=n} x_{ij} - \frac{1}{2} m \cdot (n+1) \right]^2}{\frac{1}{12} m^2 (n^3 - n) - m \sum_j T_j} \quad (3.4.2-3)$$

where m = number of experts;
 n = number of hazards;

$$T_j = \frac{1}{12} \sum t_j (t_j^3 - t_j)$$

t_j = number of iterations of each rank in the j -th line.

Standard values of concordance coefficient W are given in [Table 3.4.2](#).

Table 3.4.2

Standard value of W

W	$>0,7$	Good concordance
	$0,5 \div 0,7$	Tolerable concordance
	$<0,5$	Intolerable

3.4.3 Coefficient of pair correlation.

Rank correlation techniques are applied for working problems associated with processing of information having qualitative and comparative nature.

In classifying the qualitative information, the so-called ranking is applied which implies the arrangement of n objects in ascending or descending order of some quantitatively nonmeasurable attribute X . A rank x_i indicates the place that the i -th object occupies among other n objects ranked according to the attribute X .

A coefficient of rank correlation ρ presents statistics of ranked objects linkage. This coefficient evaluates the linkage between qualitative attributes of separate objects, which are not subject to precise quantitative evaluation

$$\rho = 1 - \frac{6S(d^2)}{n(n^2-1)} \quad (3.4.3-2)$$

where n = number of objects;

$$S(d^2) = \sum_{i=1}^n (x_i - y_i)^2 \quad (3.4.3-2)$$

where x_i, y_i = properties in question.

Properties of the coefficient of rank correlation

$$-1 \leq \rho \leq +1$$

$\rho = 0$ means that the attributes X and Y for n objects are independent by ranking these objects for the attribute Y .

$\rho = -1$ means that ranking of objects for the attributes X and Y is fully opposite.

In case of ranking with tied ranks the coefficient of rank correlation shall be calculated by the following formula:

$$\rho = \frac{\frac{1}{6}(n^3-n) - S(d^2) - T - U}{\sqrt{\left\{\frac{1}{6}(n^3-n) - 2T\right\} \left\{\frac{1}{6}(n^3-n) - 2U\right\}}} \quad (3.4.3-3)$$

where $T = \frac{1}{2} \sum t(t-1)$;

$$U = \frac{1}{2} \sum u(u-1);$$

t and u = number of iterations of each rank in I and II line correspondingly.

If x_i and y_i are random variables, the coefficient of rank correlation turns into an ordinary coefficient of pair correlation

$$\rho = \frac{cov(XY)}{\sigma(X)\cdot\sigma(Y)} \quad (3.4.3-4)$$

where $\sigma(X)$ and $\sigma(Y)$ = X and Y standard deviations respectively;
 $cov(XY)$ = X and Y covariation.

4 RISK CONTROL

4.1 SELECTION OF RISK CONTROL OPTIONS

4.1.1 General.

4.1.1.1 The purpose of risk control shall propose the effective and practical risk control option that comprises three principal stages:

focusing on areas of risk needing control;

identifying potential risk control measures;

grouping risk control measures into practical regulatory options.

4.1.1.2 In the course of materialization of [4.1.1.1](#), the procedure for selection of the risk control option that is acceptable both for existing traditional accident situations and accident situations caused by new technologies or new methods of operation, shall be created. At the first stage, the classification of the QRA results is carried out so that main efforts are focused on the areas most needing risk control. The main aspects to be reflected therewith are the following:

accidents with an unacceptable risk level become primary focus;

in construction of a fault and event tree, first of all, the risks mostly contributing to the outcome are identified.

4.1.1.3 The selection of a risk control option is above all associated with specific risk control measures. It is recommended a detailed causal chain when the risk control measures are being identified:

hazard → accident situation → accident → consequences.

Risk control measures shall be aimed at:

reducing the frequency of failures through better design, use of up-to-date technologies, organizational policies, training;

mitigating the effect of failures in order to prevent accidents;

alleviating the circumstances in which failures may occur;

mitigating the consequences of accidents.

4.1.1.4 In the course of risk control selection, the relevant measures shall be grouped into a limited number of well thought out practical regulatory options.

Two feasible approaches for group in individual measures are recommended:

"general approach" which provides risk control by the assessment of the accident initiation probability; this approach may be effective in preventing several different accident sequences;

"distributed approach" which provides control of escalation of accidents, together with the possibility of influencing the later stages of escalation of other, perhaps unrelated, accidents.

4.1.1.5 The selected way of risk control is assessed for its effectiveness with regard to risk reduction using techniques specified in [Section 3](#).

As the result of the risk control option selected, the list of arrangements for its materialization is drawn up.

4.1.2 In environmental effects.

4.1.2.1 Selecting the architectonic-constructive type of a platform, the possibility of minimizing external loads applied shall be taken into account in every possible way for which purpose the contemporary methods of analysis of effects and platform responses are used.

4.1.2.2 In consideration of platform safety issues in external effects, all their adverse combinations shall be allowed for. For the platforms fixed on the seabed, safety shall be ensured with due regard for seabed property changes in service.

4.1.2.3 On ecologically critical platforms, inspection and measuring equipment shall be provided to notify the personnel of adverse consequences of external effects. This equipment

may incorporate monitoring of the environment and main responses of the platform to severe effects (sea, ice, seismic effects, seabed reactions).

The Register approves the installation of developed systems of inspection and measuring equipment on the new type platforms what provides the possibility of its use in a research mode to accumulate the data on platform behavior in intended and unintended situations.

4.1.3 In collisions with ships and floating objects.

The most efficient and effective means of risk control is the establishment of safety echelons around platforms.

At the design stage, the conception of safety shall be created that includes the three-stage control of risk for which purpose are introduced:

- safety echelons around the platform;
- effective protection of the hull against a collision;
- limitations of damage parameters.

4.1.3.1 Platform safety echelons include two types.

The external echelon (2 to 6 mile-zone around the platform) where limitations on ships speed and routing apply. The extent of limitations depends on:

- ship's type, displacement and draught;
- ship's manoeuvrability;
- ship's equipment (CPP, thrusters, rotary propellers, active positioning systems, etc.).

The limitations on towing of poorly-controlled objects shall be applied within the echelon.

The internal echelon (0,5 to 2 mile-zone around the platform) where strict limitations on ships presence apply; the velocity towards the platform along the zone radius shall be not more than 2 to 4 knots depending on the ship, its displacement, manoeuvring capabilities, systems of ship and platform protection against a collision; any towing of poorly-controlled objects within the echelon is excluded.

The radii of the safety echelons may be corrected depending on the platform type (self-elevating MODU, semi-submersible MODU, FOP and TLP).

For the FOP being also an oil storage, an additional zone of estrangement within $\leq 0,5$ miles is established where the presence of any ships and floating objects after completion of their operations with the platform is absolutely forbidden.

Monitoring and prevention of ships traffic and presence in the safety echelons shall be carried out from the platform.

4.1.3.2 The effective structural protection of the platform hull against a collision with ships shall include shock-absorbing and deformation protection of the hull.

The shock-absorbing protection of the platform against ships being moored at sea is ensured with pneumatic fenders or other shock-absorbing means equivalent with respect to energy intensity and a specific contact force.

The platform deformation protection is ensured with structures being crumpled and scattering the impact energy during their deformation, and dampening the contact force down to the value that the deformation protection may take up.

It is allowed to use one type of protection on the platforms and another, on supply and transport ships.

The effective structural protection of the platform shall ensure, according to Part II "Hull" of Rules for the Classification and Construction of Sea-Going Ships, the mooring of special purpose ships at sea state up to 6 inclusive.

For the FOP being also an oil storage, a special structural protection as part of a mooring/transfer-at-sea system is needed which shall be agreed with the Register by a designer in an established order. The midpart of the FOP inclined sides span in the area of the ships approach shall be reinforced with vertical stiffeners or inclined stops to avoid deformations of spans due to ship potential crawling over.

4.1.3.3 Where the protection, nevertheless, proved to have been broken through and the platform has received the hull damage, its outside dimensions shall not exceed those confirmed by special calculations.

If the overall dimensions of the damage are exceeded, the Register has a right to make a decision on the increase of the risk level of platform operation and on the necessity of its removal from operation. The permissible parameters of the damage shall be determined according to [4.1.6](#). In case of leakage, urgent measures on its elimination shall be taken and, where necessary, the package of measures according to Part V "Subdivision" of the Rules for the Classification and Construction of Sea-Going Ships, shall be followed.

4.1.4 With explosions, dropping and flying objects.

4.1.4.1 The measures to control the risks associated with explosions, dropping and flying objects and also with the helicopter accident may be integrated into two groups as to their impact on various stages of an accident:

measures affecting the potential source of an accident situation and ensuring the reduction of the probability for accident situation occurrence;

measures affecting accident progress and ensuring the reduction of its consequences.

The first group measures only relate to the sources of explosions and dropping (flying) objects, which are present on the platform.

4.1.4.2 The key measures of the first group are:

conservative approach during design based on the wide use of accumulated positive design experience for safety assurance;

performance of periodical inspections (surveys, etc.) of equipment and other sources of explosions and dropping (flying) objects in the course of operation; the inspections shall be rather frequent to ensure a proper time reserve between the detection of a fault (failure) and the potential destruction;

use of observation systems for sources featuring rather high (close to a maximum for the given type of events) parameters and characteristics of striking factors; an observation technique shall provide for monitoring of certain conditions which may point to failure start; the example of such a system is the system of vibration sensors on large-sized equipment with rotating parts.

The first group measures shall also include the whole package of fire-fighting measures.

4.1.4.3 The key measures of the second group are:

arrangement, grouping and relevant positioning of equipment;

redundancy of systems which can effect on the progress and magnitude of accident consequences;

physical separation of stand-by safety systems;

use of special protective structures (structural protection systems);

use of standard structures (by their special design) as protective barriers;

ensuring of preferable (the least hazardous for the magnitude of consequences) accident progress (propagation of striking factors).

4.1.4.4 In order to ensure the required safety level (tolerable risk level), it is usually needed to implement the package of the first and second group measures.

The best shall be considered the approach, which allows to reduce down to an acceptable small value the probability of occurrence of an explosion, flying or dropping objects. The measures of the first group are aimed at it.

The next in preference is the approach ensuring reduction or exclusion of striking factor effects on the object (space, equipment, personnel, etc.), which is essential for safety. And the following is the approach, which ensures the acceptable magnitude of consequences. The second group measures are aimed at handling the last two problems.

4.1.5 In fires and blowouts.

In order to ensure safety in fire on a MODU, the package of fire-fighting measures shall be implemented. It makes sense to divide all these measures into four groups.

4.1.5.1 The first group deals with the measures of organizational character, namely: development and formal drawing up of instructions for performance of all the works on the MODU;

development of duty regulations for the MODU entire personnel;

strict observance of the standards and requirements of safety regulations during performance of any works on the unit, implementation of an allowance system for conducting all fire-hazardous works;

development and formal drawing up of clear instructions for personnel actions in fire extinguishing;

development and implementation of a training system on the MODU with the check of knowledge obtained by personnel.

4.1.5.2 The second group includes the measures of technical character aimed at prevention of the possibility of fire occurrence on a MODU. The most essential of them are:

application of the explosion-proof and fire-proof equipment, machines, machinery, devices and systems in fire-hazardous areas and spaces of the MODU;

installation on the MODU of a special system preventing oil and (or) gas blowout;

use on the MODU of systems for transfer of combustible liquids in which the possibility of fuel or lubricating oil leakage is kept to a minimum;

maintenance of relevant air composition in MODU spaces by installation of gas-analysing and ventilation systems;

limitations on the use of combustible materials in MODU service, general purpose and accommodation spaces.

4.1.5.3 The measures on passive protection against fire aimed at prevention of its propagation on a MODU (Part VI "Fire Protection" of Rules for the Classification and Construction of Sea-Going Ships) form the third group of fire-fighting measures. In terms of risk control, the following measures among them shall be considered as crucial:

module design of the unit according to a technological principle;

separation of one module from the other, as well as of one fire-hazardous space from another by cofferdams or gastight fire-resistant bulkheads;

implementation of special measures for ensuring safe evacuation of personnel from any service, general purpose or accommodation spaces through passageways, corridors, trunks fitted with fire protection;

arrangement on a MODU of a special space- shelter in which the personnel may be in safety over a certain period of time needed either for fire extinguishing or evacuation of people from the MODU.

4.1.5.4 The fourth group includes active measures on fire fighting. It comprises fire extinguishing systems, which use various physical and chemical principles of operation, namely:

water fire main system;

sprinkler system;

pressure water-spraying system;

water-screen system;

drenching system;

carbon dioxide smothering system;

inert gas system;

foam fire extinguishing system;

dry powder system;

aerosol system.

4.1.6 Structural sufficiency.

4.1.6.1 The problems of structural sufficiency control shall be considered during design, construction and operation of offshore platforms, and also during hull structure updating.

Structural sufficiency is ensured through:

- structure strength;
- structure integrity;
- operational reliability;
- structure endurance.

4.1.6.2 The main concern in assurance of structural sufficiency shall be with:

- special structural elements;
- main structural elements essential for assurance of tightness and for safety of platform operating personnel (e.g. helideck structures, a working deck, areas of ships mooring);
- main structural elements essential for structure endurance.

4.1.6.3 The measures for control of structural sufficiency (which may be organizational, technical, structural, etc.) are subdivided into traditional, additional and special.

4.1.6.3.1 Traditional control measures are aimed at assurance of structure strength, structural integrity, operational reliability and regulated by the requirements of Part II "Hull", Guidelines on Technical Supervision of MODU/FOP in Service, etc. (refer to 2.1.2).

4.1.6.3.2 Additional control measures are mainly aimed at assurance of structural integrity, operational reliability and associated with the use of non-traditional materials, unique structures and units, non-traditional inspection techniques.

4.1.6.3.3 Special control measures are mainly aimed at assurance of structure endurance and necessarily associated with the evaluation of an accident situations possibility (refer to 2.1.3).

4.1.6.4 The traditional control measures include:

- .1** during design:
 - calculation of structure strength for given loads in accordance with accepted criteria;
 - meeting the requirements for minimum thicknesses;
 - development of special instructions and normative documents on assurance or the operational reliability of a structure (e.g. Instructions for MODU Operation, Methodical Instructions on Assessment of Technical Condition of the Hull, Recommendations for Underwater Survey, etc.);
 - examination of strength calculations, other arrangements for assurance of design quality;
- .2** during construction:
 - control of main material quality;
 - control of structural element joints quality;
 - control of structure manufacture at large, other measures for assurance of manufacture quality;
- .3** during operation:
 - the periodical survey and inspection for defects of structural elements and their joints including the inspection of the underwater part of a structure using contemporary technical means of underwater examination;
 - identification of structural elements which do not meet the requirements of the normative documents for assessment of the technical condition of a structure;
 - repair of structural elements.

4.1.6.5 Additional control measures.

4.1.6.5.1 The additional control measures during design include:

- experimental studies of strength and operability of non-traditional hull structures and units;
- development of special requirements for engineering of unique structures and units;
- experimental studies of non-traditional materials and development of special requirements for them;

development, where necessary, of special normative documents to ensure operational reliability of non-traditional structures, development of special requirements for non-traditional control systems like automated monitoring of environmental parameters, acoustic and emission monitoring of fatigue cracks propagation, monitoring by sample witnesses, etc.

4.1.6.5.2 The additional control measures during construction consist of use of non-traditional materials and monitoring of manufacture quality for structures made thereof.

4.1.6.5.3 The additional control measures during operation consist of use of non-traditional monitoring systems and assurance of their operation quality.

4.1.6.6 The special control measures are developed in the course of design and implemented during platforms construction and operation.

4.1.6.6.1 On the whole the adequate protection against an accident damage is achieved by two ways:

- low damage probability;
- tolerable damage consequences.

The special control measures are mainly aimed at the tolerable damage consequences.

4.1.6.6.2 The control measures for assurance of structure endurance include:

structural measures in order to withstand the effects of accident events or to reduce to a minimum their consequences;

organizational measures for accident rate reduction like the development of special accident plans and arrangements with regard to the minimization of the risk of a collision with ships, icebergs and of other accident events;

the measures of technical character associated, for instance, with the use of systems and devices for monitoring machinery whose damage may result in the destruction of the platform hull (e.g. such a mechanism is the jacking system of a self-elevating MODU).

4.1.6.6.3 Structural redundancy is of vital importance for assurance of structure endurance. A structural system shall be so selected that its carrying structure and the most essential elements retain integrity in the course of and immediately after an accident while other structural elements therewith may be damaged. Following the damage, the structure shall withstand minimum functional and environmental loads during the certain period of time up to platform removal from operation.

4.1.6.6.4 The Register may require the calculations and other motivations based on an engineering approach which validate that the strength of the hull with a damaged element will be ensured, i.e. the damage of a certain strength member (members) will not cause platform hull destruction.

This problem shall be worked out with due regard for

design conditions of a damage (damaged elements, other parameters) shall be established to fit a particular offshore platform in terms of accident situations and structural features of a structure under consideration;

where the special instructions in the relevant parts of the MODU/FOP Rules and other normative documents of the Register are unavailable, as design loads shall be used functional loads due to the platform, cargo and equipment weight only (i.e. it is assumed that machinery, systems and arrangements may be inactive), and also environmental loads corresponding to the largest during a year for the area of operation in question;

an ultimate strength criterion shall be assumed as a strength criterion according to the formula

$$F \leq R \tag{4.1.6.6.4}$$

where F = design value of a generalized force effect;
 R = design value of a generalized bearing capacity (design structure resistance);

calculation methods may be based on the plastic analysis of structural elements behaviour.

4.1.6.7 The above provisions on structural sufficiency control shall be perceived as the minimum requirements of a general nature on which basis the individual requirements to fit the offshore platform of the particular type shall be determined with due regard for the assessment of an accident situations possibility.

4.1.6.8 The control measures on structural sufficiency will be more convincing if available data in respect of platform structure damages due to accident events are used. Accumulation of such data shall be conducted in form of [Appendix 4](#).

4.2 COST BENEFIT ASSESSMENT ASSOCIATED WITH MEASURES ON RISK REDUCTION

4.2.1 The purpose of this step shall identify benefits and costs associated with the implementation of each risk control option identified and defined in [4.1](#).

4.2.2 A cost benefit assessment consists of the following stages:
consider the risks assessed in [Section 3](#), both in terms of frequency and consequences, in order to define the base cause in terms of risk levels of the situation under consideration;

classification of the risk control options, defined in [4.1](#), in a way to facilitate understanding of the costs and benefits resulting from the adoption of one or other option;

estimate the pertinent costs and benefits for all risk control options;

estimate and compare the cost effectiveness of each option in terms of the relative cost per unit risk reduction;

classification of the risk control options from a cost-benefit perspective in order to facilitate the decision making recommendations in the next step (e.g. to screen those which are not cost effective or impractical).

4.2.3 Costs shall cover the entire life cycle and may include an initial cycle, operation, training, inspection, certification, etc. Benefits may include reductions in the costs associated with fatalities, injuries, casualties, losses environmental damage, indemnity of third party liabilities, and an increase in the average life of the structure.

The evaluation of the above costs and benefits can be carried out by using various methods and techniques. Such a process shall be conducted for the overall situation in order to identify the main effects.

A cost is determined in relation to the person, organization, company, coastal zone management, etc. who is directly or indirectly affected by an accident. In this step, the effectiveness of the new proposals is determined. In the initial stage of a formal safety assessment (FSA), the basic risk directions shall be grouped together for the purposes of applying the FSA methodology and identifying decision making recommendations.

As the result are assessed:

costs and benefits for each risk control option identified in [4.1](#);

costs and benefits for the measures which are the most influential on the result;

cost effectiveness expressed in terms of net cost per unit risk reduction.

4.2.4 The cost effectiveness of the measure selected is recommended to determine working a probability-optimization problem either on the basis of minimization of a P -type effectiveness function

$$P = S + p\bar{u}; \quad (4.2.4-1)$$

or on the basis of the method of increments

$$I = S\Delta - \bar{u}\delta p \quad (4.2.4-2)$$

where

I	=	measure benefit;
S	=	initial cost of the structure, equipment, platform;
\bar{u}	=	probability average loss in case of a failure;
p	=	probability of a failure (risk value) referred to the entire life time of the structure, equipment, platform.
Δ and δ	=	relevant increments.

4.2.5 It is recommended to use the following criterion as the price evaluation of fatalities:

$$S_F = \frac{\Delta C - \Delta B}{\Delta R} \leq A_S \quad (4.2.5)$$

where

S_F	=	net value of prevention of fatality;
ΔC	=	cost of recommendations to the platform proceeding from the third step of the formal safety assessment (risk control);
ΔR	=	reduction of risk per ship in relation to the number of prevented fatalities on the basis of risk control;
A_S	=	price measurement of risk control. At a first approximation min USD considering the foreign sources.

5 CRITERIA OF PLATFORMS SUFFICIENT SAFETY

5.1 RECOMMENDATIONS FOR DECISION MAKING ON ACCIDENT RISK REDUCTION

5.1.1 The purpose of this step shall define the recommendations on the reduction of an accident risk. The recommendations shall be based on the comparison and ranking of hazards and their underlying causes, on the comparison of risk control options and shall be followed in order to reduce the risk down to the most reasonable level.

Output from these actions shall provide an objective comparison of alternative options, based on the potential reduction of a risk level and cost effectiveness of risk control options, including areas where standards and rules shall be reviewed or supplemented. The recommendations shall be correlated in various contexts with the IMO recommendations and shall not contradict the IACS approaches.

This step is the most important in the entire chain of FSA actions and shall be thoroughly considered.

5.1.2 All the decisions made for accident risk reduction shall meet the effective Rules of the Register and operational standards specified in appropriate operating instructions approved by the Register in order to ensure platform safety.

Operational standards are used everywhere during the platform entire life cycle. It is vital that they be related to the systems and processes, which facilitate the reduction of a total risk, the number of the operational standards therewith shall facilitate the better safety management.

The operational standards are related to a particular platform and they are recommended to be formed at three levels:

risk-based operational standards which specify the quantitative parameters to be met (refer to [5.3](#));

operational scenario standards which may be qualitative or quantitative specifying a final purpose for management when a specific hazard or group of hazards occur;

operational system standards which specify the level of activity or competence that is needed from the system called for management when a hazard occurs.

5.2 AS LOW AS REASONABLY PRACTICABLE PRINCIPLE

5.2.1 The identification of hazards and analysis of consequences of their materialization allow even in the first step to define some, even though, preliminary priority of hazards. For this purpose a risk matrix is used according to which all hazards are distributed over three levels: intolerable, as low as reasonably practicable (ALARP), and tolerable.

Intolerable hazards are those in respect of which the risk can not be justified except in extraordinary circumstances. Among such hazards are the ones whose materialization probability has an ordinary average level, but consequences are catastrophic.

Tolerable hazards are those whose materialization is remote, and the consequences are insignificant. In respect of such hazards, no precautions are needed and they may be excluded from further consideration.

The regulation of tolerable and intolerable values of risks is given in 5.3. The ALARP (as low as reasonably practicable) level falls between the "tolerable" and "intolerable" levels.

The base risk matrix is illustrated in Fig. 5.2.1. The materialization of the risk matrix is carried out according to the identification of specific potential risks. Following the definition of an objective, the team (group) of experts performing the examination within the framework of a FSA methodology is formed. The work is recommended to be conducted in three phases: preparation, identification of risks, processing and documenting.

FREQUENCY				
Frequent	ALARP level 4	ALARP level 3	Level 2	unacceptable level 1
Reasonably probable	ALARP level 5	ALARP level 4	ALARP Level 3	level 2
Remote	level 6	ALARP level 5	ALARP Level 4	ALARP level 3
Extremely remote	acceptable level 7	level 6	ALARP Level 5	ALARP level 4
	Insignificant	Minor	Major	Catastrophic
				CONSEQUENCES

Fig. 5.2.1
Risk matrix

ALARP = as low as reasonably practicable

Where risk cannot be quantified, the qualitative qualification of accident circumstances is allowed using the following definitions for accident magnitude categories and the accident probability according to Tables 5.2.1-1 to 5.2.1-5. The qualitative qualification allows to complete the risk matrix in which the levels 1 and 7 present the highest and the lowest risks, respectively. The ALARP zone is consistent with three to five levels.

Table 5.2.1-1

Accident magnitude (consequences)

Insignificant	No significant damage to people, equipment and the environment
Minor	Insignificant reduction in platform performance, local damages
Major	Significant reduction in platform performance accompanied with serious injuries
Catastrophic	Platform loss or ecological catastrophe

Table 5.2.1-2

Accident probability

Extremely remote	Only likely to happen in exceptional cases
Remote	Unlikely, but not unknown, to happen during the life cycle of a platform
Reasonably probable	Likely to happen during the life cycle of a platform
Frequent	Likely to happen yearly or more frequently

Table 5.2.1-3

Risk matrix for long-distance transportation of bulky cargoes

FREQUENCY					
Frequent	M	M	H	H	H
Reasonably probable	L	M	M	H	H
Probable	L	L	M	M	H
Extremely remote	L	L	L	M	M
Remote	L	L	L	L	M
	Insignificant	Minor	Medium	Major	Catastrophic
	CONSEQUENCES				

Note. L – low, H – high, M – ALARP level – "as low as reasonably practicable".

Table 5.2.1-4

Consequences

Insignificant	Event which causes no significant damage to people, equipment and the environment
Minor	Insignificant reduction in platform performance, local damage and injuries to people requiring rendering first aid
Medium	Damage to the platform commensurable with acceptable level. People are bruised and suffer minor
Major	Essential damage to some platform structures and securing devices accompanied with serious injuries requiring professional medical treatment
Catastrophic	Platform loss and, maybe, casualties

Table 5.2.1-5

Damage probability

Frequent	Likely to happen many times during long transportation
Reasonably probable	Likely to happen several times during long transportation
Probable	Likely to happen once during transportation
Remote	Likely to happen not more than once for 3 – 4 transportations
Extremely remote	Only likely to happen in exceptional cases

5.3 NEGLIGIBLE AND UNACCEPTABLE RISK LEVELS

5.3.1 As safety criteria for annual individual risks r shall be accepted:
unacceptable risk level = 10^{-3} per year;
negligible risk level = 10^{-6} per year.
The range between 10^{-3} per year and 10^{-6} per year is the ALARP region,

GENERAL RECOMMENDATIONS FOR DRAWING UP AND USING OF A CHECKLIST OF SELF-ELEVATING MODU 6500/100 JACKING SYSTEM

I. BRIEF TECHNICAL DESCRIPTION OF SELF-ELEVATING MODU 6500/100 JACKING SYSTEM

The self-elevating MDU 6500/100 "Murmanskaya" has three trihedral gridwork legs and is intended for exploration drilling of wells up to 6500 m deep in water depths in a drilling position from 20 m to 100 m at the air temperature within $-30\text{ }^{\circ}\text{C}$ to $+40\text{ }^{\circ}\text{C}$. A wind force 6 and sea state up to 5 during the platform transit are assumed as acceptable.

Main technical characteristics:

light displacement afloat abt. 15000 t;

length (design) abt. 88,2 m;

breadth (design) abt. 68,0 m;

depth abt. 9,7 m;

draught (light) abt. 5,3 m;

length of the trihedral gridwork leg abt. 143 m.

The jacking system with a rack-and-pinion mechanism, operating by a step-by-step principle, is installed on the self-elevating MODU. It consists of three jacks mounted on a jack house at each leg corner and of a moving yoke, which encloses the leg, with three racks connected to it by means of articulated joints. The jack includes three twin reduction gears with two output gear wheels, electric motors and brakes.

The catching gear being part of the jack mechanism includes three catches (one at each corner of the leg) located on the yoke and three catches similarly arranged at the lower part of the jack house. The catch pins are driven (slid in and out of the special openings in the nodal joints of vertical corner struts of the legs) with pneumatic drives.

The work cycle of the jack consists of two operations:

working run – elevation (lowering) of the pontoon (leg);

idle speed – rearrangement of the yoke for one step downwards or upwards.

The lower catches activate in the end of the working run joining the pontoon and leg. Following the full load transfer to the lower catches, the upper ones set the yoke free for rearrangement, i.e. movement of the yoke with racks for one step till the activation of the upper catches. The lower catches set the leg free and the next working run follows.

In order to reduce stresses and deformations of the vertical strut, the technological lugs in its cast nodal joints are provided to ensure transmission of transverse loads in the nodes of a leg grid only. The similar contact supports ("skis") are fitted in the hull of the self-elevating MODU in three pieces at each vertical strmt. The protruding nodes of the vertical struts slide along them in platform rearrangement and rest on them in operation.

II. GENERAL RECOMMENDATIONS FOR DRAWING UP AND USING OF THE CHECKLIST OF AN ACCIDENT SITUATION ANALYSIS AS APPLIED TO THE JACKING SYSTEM OF A SELF-ELEVATING MODU

1 Introductory part

The checklist of an accident situation analysis in the platform areas with an average and high risk level helps to identify mistakes in a design and a potential threat to safety using the list of questions intended for the encouragement of thinking and a discussion process.

The questions in the checklist usually deal with those areas where there were mistakes in a design or in operation. The significant part of the questions is the outcome of the examination of the problems identified in previous reviews or as the result of accidents. The checklist does not concern, as a rule, the areas where designers rarely make mistakes. The checklist shall be used only for the thorough and comprehensive review of a design, but not as a design technique for the unit or its separate areas.

2 Pertinent information

The procedure for use of the checklist demands knowledge of the sound background of the design, equipment layout, safety and fire protection systems, operational technology, etc. The package of documents shall be stored during the entire life cycle of the unit as the basis for future modifications and the accident situation analysis.

3 Methods

In order to perform the analysis of accident situations, a team is formed which includes the representatives of a design organization, operators and at least one experienced specialist not directly involved in unit's design or operation. The analysis may be conducted both by one specialist and by small groups, each in its discipline.

To facilitate a review, the checklist is usually divided into some sections, and in doing so, as applied to the jacking system of the self-elevating MODU, in the following sections (refer to column 1 of the [Table](#)).

The checklist does not contain the requirements for answering each question with "yes" or "no". Experts shall use the checklist questions as the lines of thinking and identification of potential problems.

The checklist questions are not necessarily the "requirements of design safety". In many cases, they confer a right on questioning participants for selection. It may be expected that the review and analysis of accident situations according to the checklist on even an existing platform will turn into the larger number of undesirable answers than the review of a new design, as an additional risk in terms of safety is associated with a need to update the actually existing unit.

4 Report

The analysis shall be documented so that it may be identified who and when conducted it, which information was examined and the subsequent recommendations. The hazards identified and recommendations obtained as the result of answers for questions are reasonably to present as a master table, which is like the one whose form, is given in the end of the present Appendix. Each item shall have references to an appropriate question of the checklist used for problem identification. These items are based on the team's assessments and discussions with the platform designers and operators. Such items shall be introduced for only those platform areas whose condition causes alarm.

Table

Analysis (review) subject	Contents	Documentation in aid of
1. General	A. General matters	Design background
	B. Layout	Drawings of general arrangement and equipment layout
	C. Response to an extreme situation	
	D. Evacuation and salvaging	
2. Mechanical part	A. Structural materials	Specification for materials, equipment, arrangements
	B. Jacking system for legs	Drawings
	C. Elevation mechanism	Patents
	D. System for legs embedding into seabed and for their puffing out	Technological procedures for the elevation / lowering of legs and for their embedding into seabed, etc.
	E. Piping	
3. Electrical part and control system	A. Electrical classification of zones	Specification for electrical equipment and devices, drawings
	B. Diagram of electric circuits laying	Specification for pipes and valves

III. EXAMPLE OF THE CHECKLIST OF SELF-ELEVATING MODU 6500/100 JACKING SYSTEM¹

1. General

1.A General matters.

1.A.1 Are hazards properly addressed?

Is the method of their elimination and control thought out?

1.A.2 Which new processes and equipment, systems and arrangements are used on the unit what may demand the more thorough analysis of safety (e.g. HAZOP)?

1.A.3 Has the operability of the jacking system been taken into account in the design? (Complicated systems will most likely be operated with violations and interlocks will later be switched off.).

1.A.4 Have the requirements for safety systems testing been defined? Does the design meet these requirements?

1.A.5 Have all hazardous materials been examined and classed?

Have the certificates for materials been examined?

Have the measures for personnel's protection been developed?

1.B Layout.

1.B.1 Are accommodation spaces, the deck house and control stations properly arranged in order to reduce contacts with the equipment and arrangements of a higher hazard?

1.B.2 Has provision been made for installation of additional equipment that may interfere with the safe operation?

1.B.3 Has the arrangement and separation of equipment and appliances between the jack house and yoke been thought out?

¹ Questions of the checklist are subdivided into groups according to the recommendation of [II.3](#) of the present Appendix.

- 1.C** Response to an extreme situation.
- 1.C.1** Is provision made for accommodation of personnel in emergence of an extreme situation?
- 1.C.2** Are communications or means of communication with ships or a shore available?
- 1.D** Evacuation and salvaging.
- 1.D.1** Is the number of seats in life-saving appliances, lifeboats and liferafts sufficient for accommodation of 100 per cent of the operating personnel including the attached one?
- 1.D.2** Is the platform provided with life-saving appliances to expand escape routes?
- 1.D.3** Is the use of lifelines as evacuation means, when the other means are ineffective, thought out?
- 2 Mechanical part**
- 2.A** Structural materials.
- 2.A.1** Is the selection of structural materials correct and the use of non-ferrous metals instead of a ferrous metal justified?
- 2.A.2** Is the combination of materials consistent with the safety requirements being effective for the sea fleet?
- 2.A.3** Are the zones for drainage of exhausted materials and corrosion products thought out and are there obstacles for their natural disposal?
- 2.A.4** Are additional technological reinforcements, including the material of welds, preventing the proper operation lacking?
- 2.B** Jacking system for legs.
- 2.B.1** Does the jacking system for legs make possible the operation with the essentially different subsidence of legs in soft soils?
- 2.B.2** Is provision made for a reliable interlock in the system when the upper and lower levels of the catching gear operate?
- 2.B.3** Does the jacking system take into account the accident catching of the leg?
- 2.C** Elevation mechanism.
- 2.C.1** Are provisions made for maintenance platforms, passageways and guards in the design of elevation mechanism arrangement according to the safety requirements being effective in the sea fleet?
- 2.C.2** Is the safe operation of the elevation mechanism and reduction gear ensured at the design level with the ingress of corrosion and sea activity products into them?
- 2.C.3** Can the elevation mechanism damage (destroy) the permutable rack, the output pinion of the reduction gear etc. while operating with the pins of the upper and lower belts secured on the leg?
- 2.C.4** Is the safe operation of the mechanism with the permutable pinion assessed during design?
- 2.C.5** Are provisions made for the testbed trials of the elevation mechanism and for the assessment of its reliability in terms of potential accident situations?
- 2.C.6** Are there limitations on wind, waves and other conditions for the jacking system during the transit of the self-elevating MODU?
- 2.D** System for legs embedding into seabed and for their pulling out.
- 2.D.1** Is the resource of the system sufficient for the withdrawal of an accident leg from seabed?
- 2.D.2** Is the plan of system operation with the leg cocked in the jack house during leg pulling out/ embedding thought out?
- 2.D.3** Is provision made for a mechanism to accommodate excess displacements due to the cocking of the leg during lowering/elevation?
- 2.D.4** Is the system fitted with the effective subsystem for washing and taking a soil off the legs, which ensures system safe operation during pulling out/embedding?

EXAMPLES OF EVENT TREES

Table 1

Event tree during pulling out the legs of a self-elevating MODU from the seabed

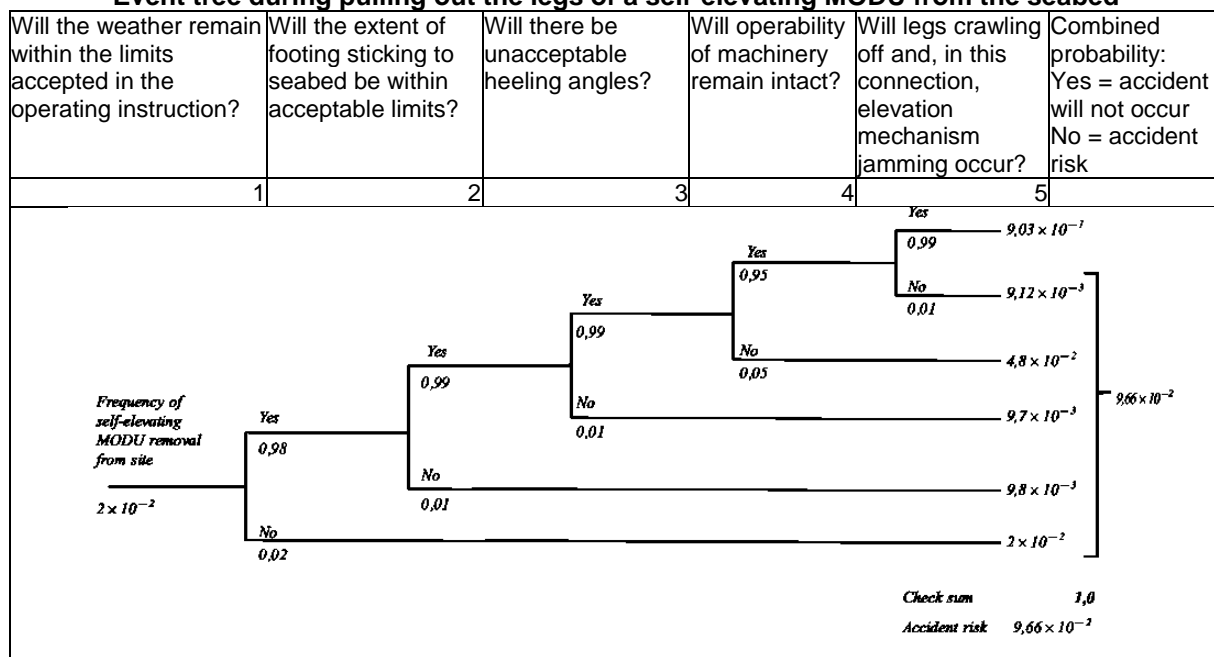

Table 2

Event tree during transportation of self-elevating and semi-submersible MODU

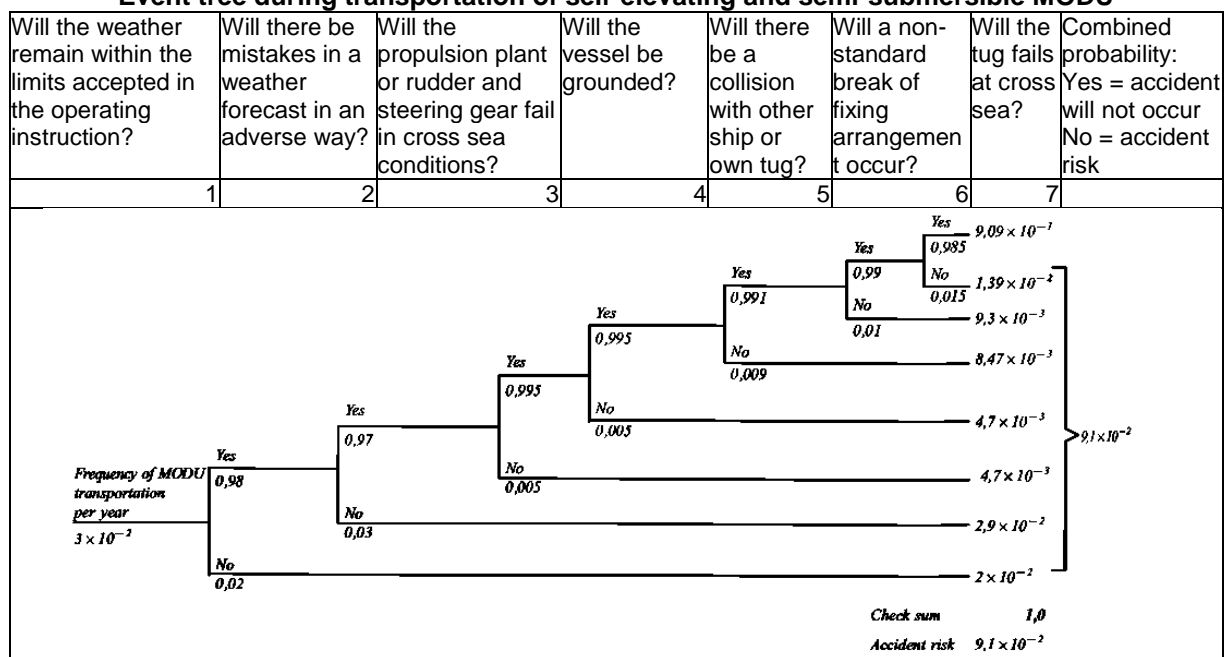

Table 3

Event tree in running aboard a self-elevating MODU

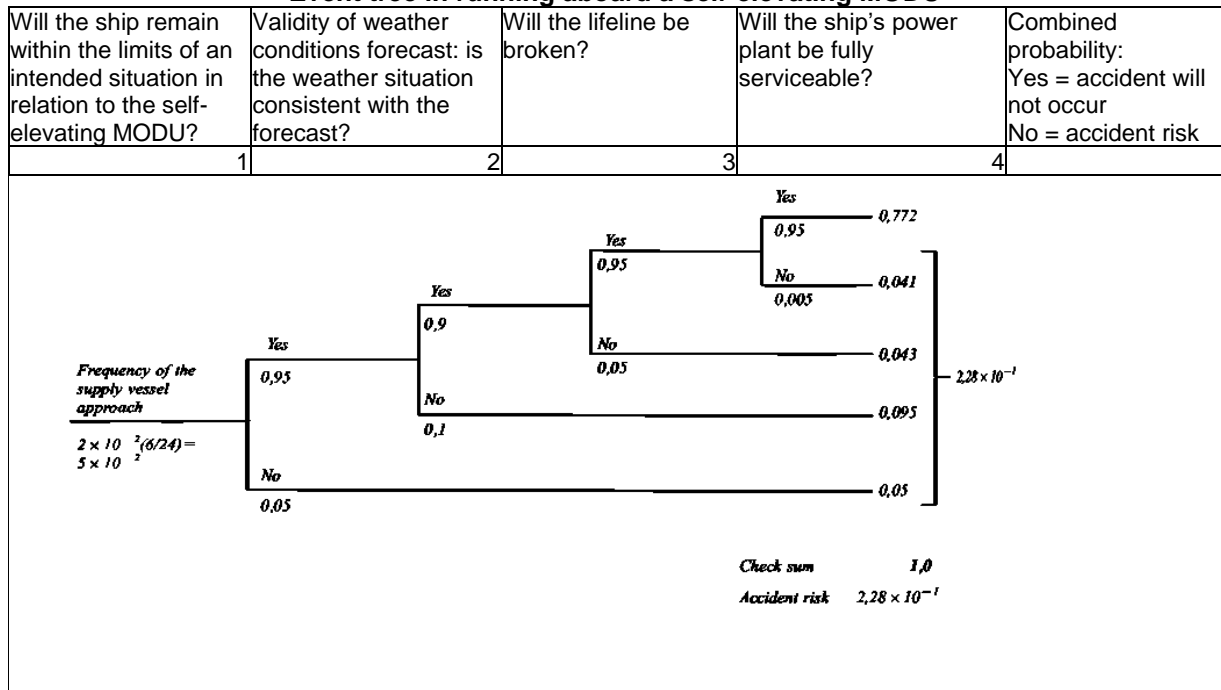

Table 4

Event tree in collision of a tanker with a fixed platform

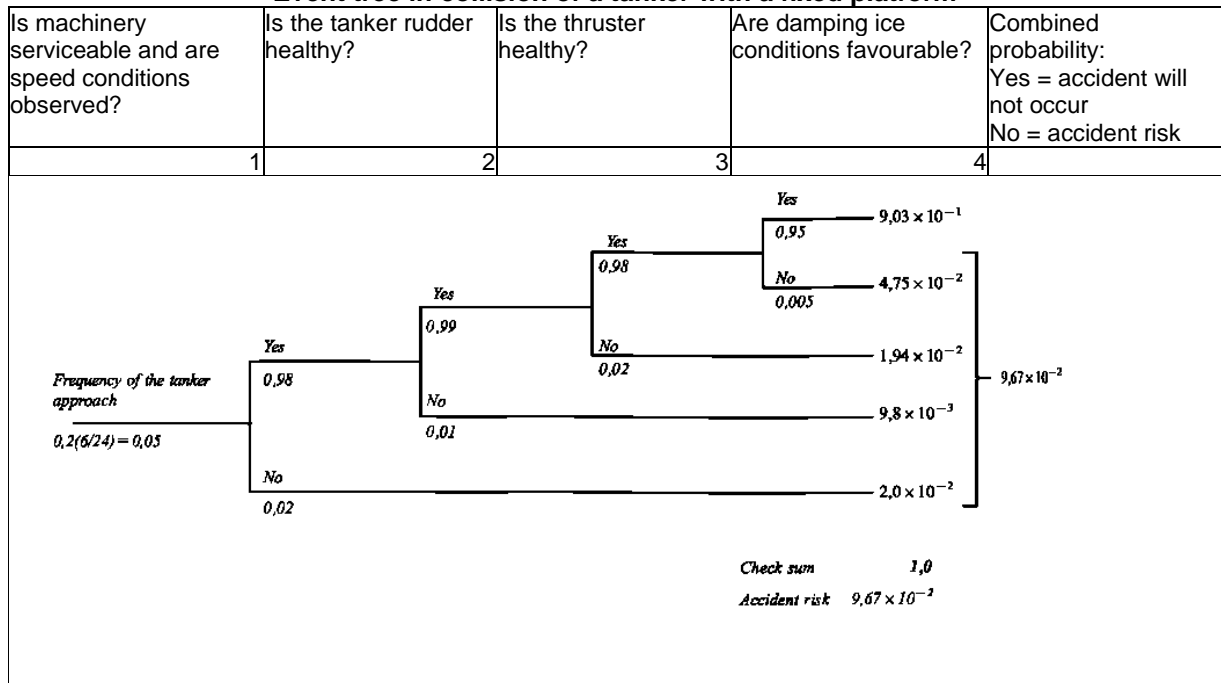

Table 5

Event tree in fire in internal spaces of a MODU

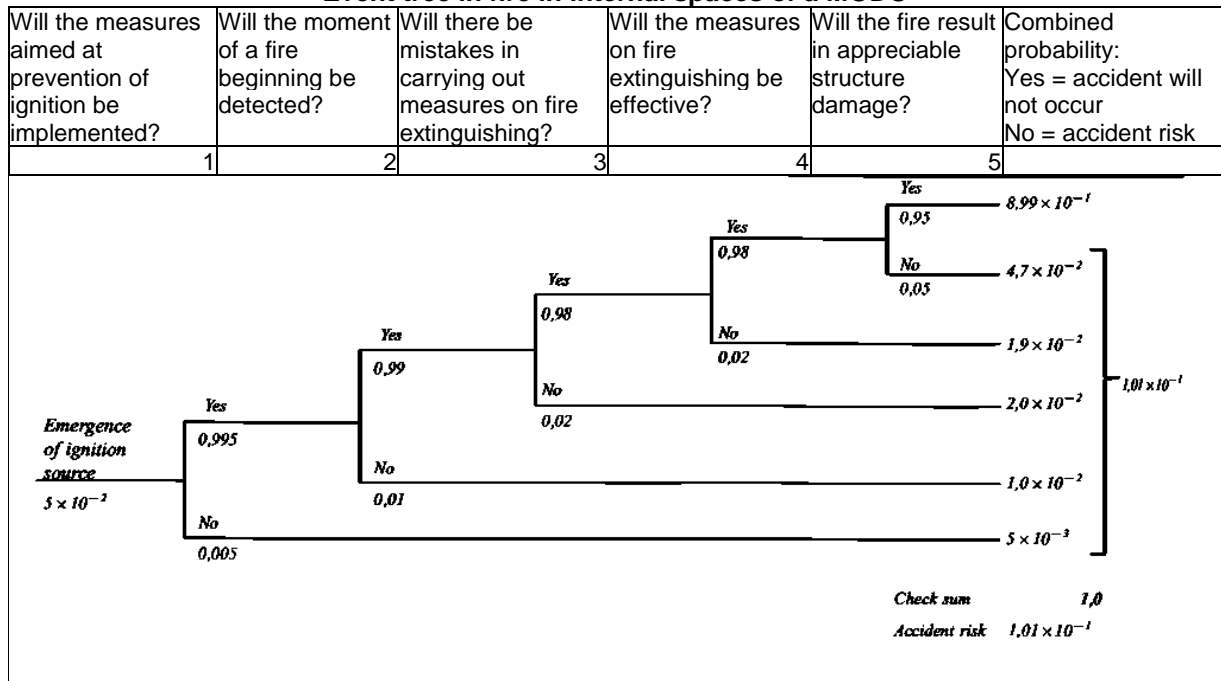

Table 6

Event tree in blowout fire aboard a platform

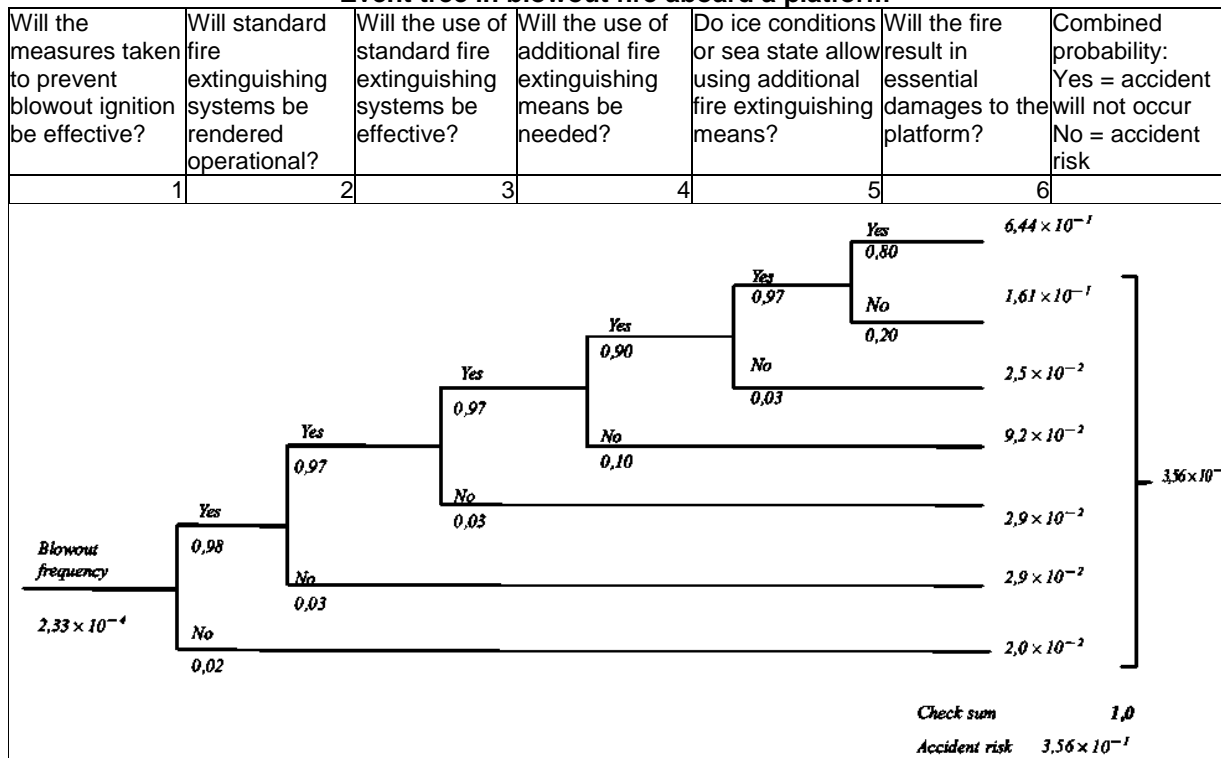

Table 7

Event tree in seismic effects on a platform

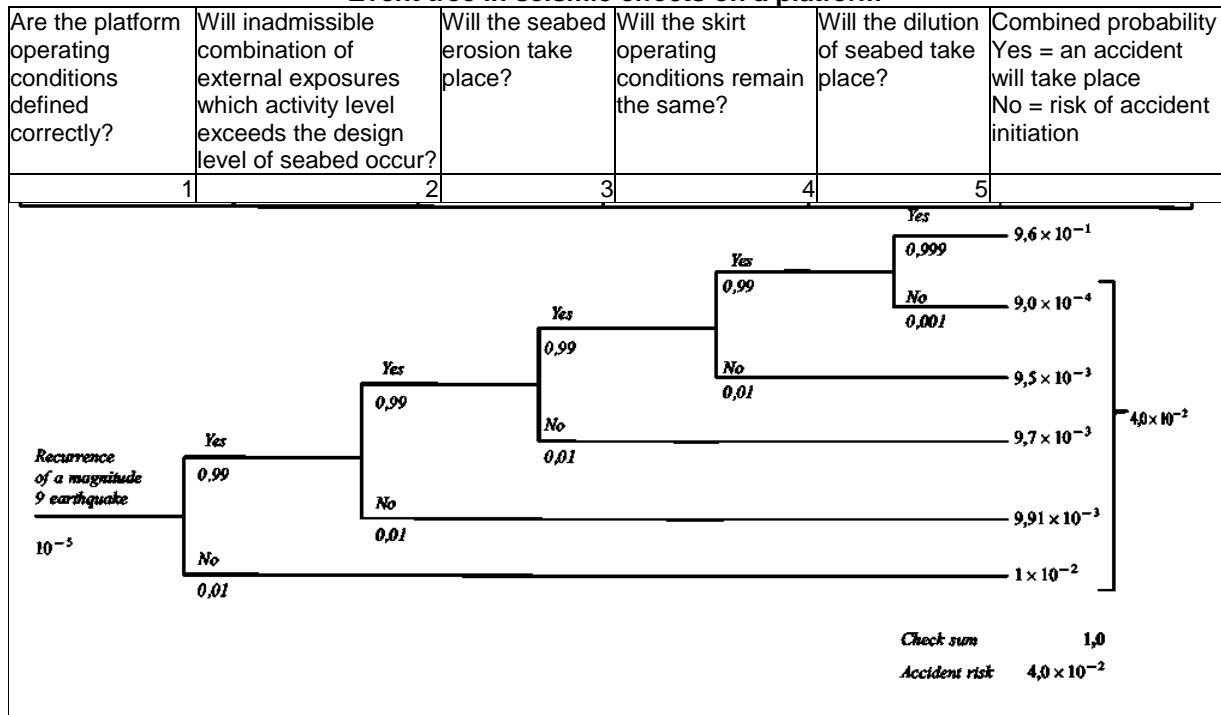
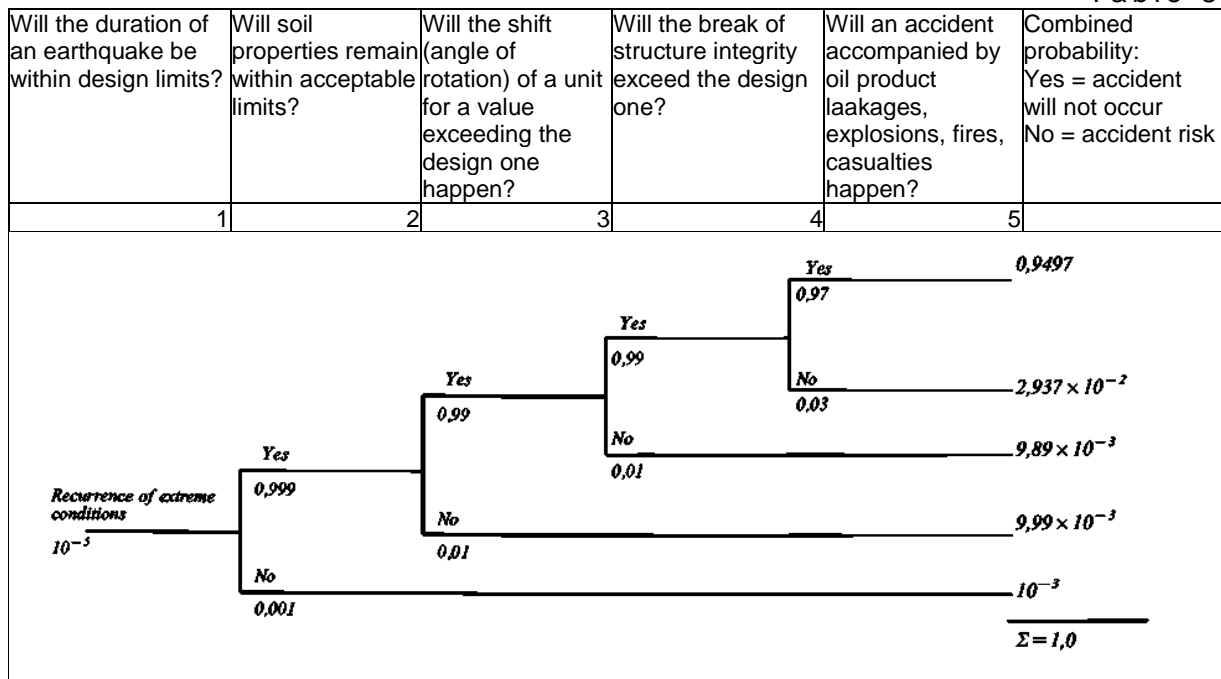
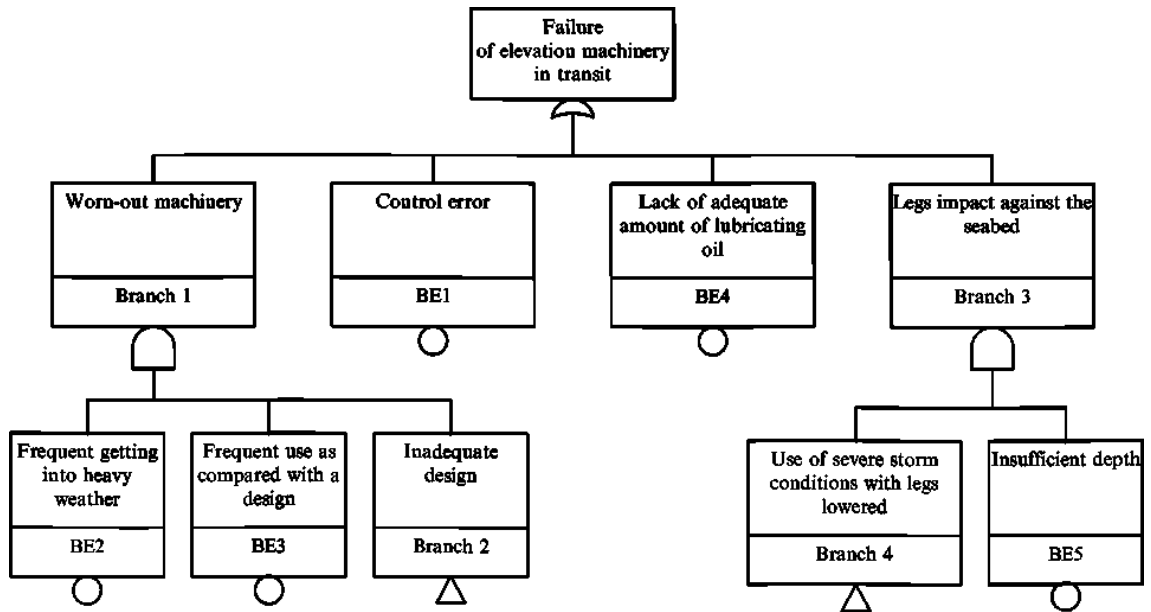

Table 8



EXAMPLES OF ERROR AND FAULT TREES



Initial construction of an error and fault tree

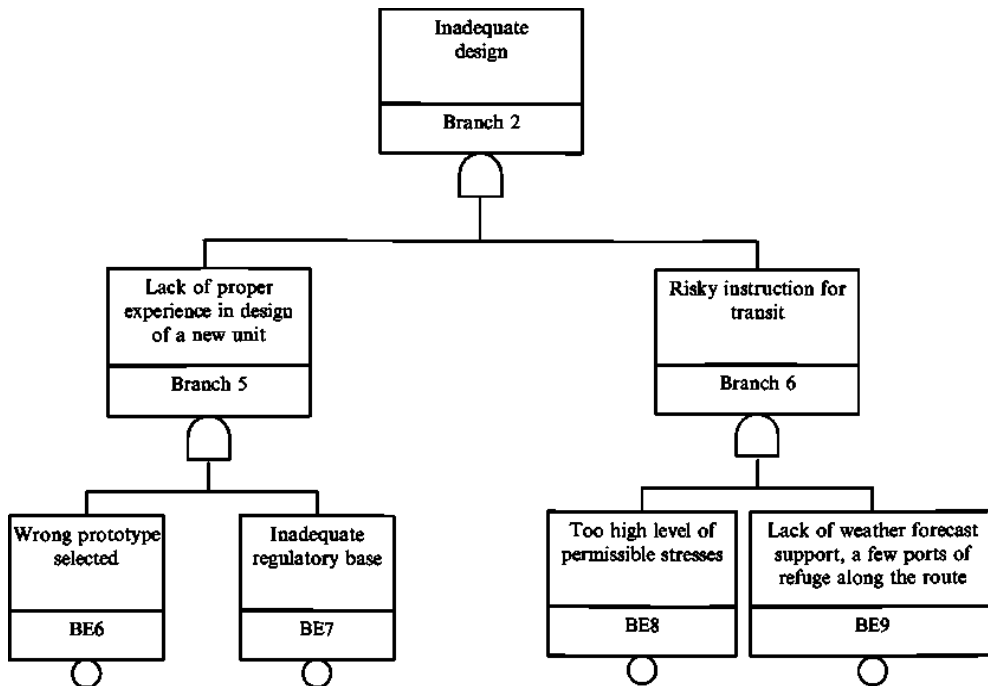

Continuation of error and fault tree construction

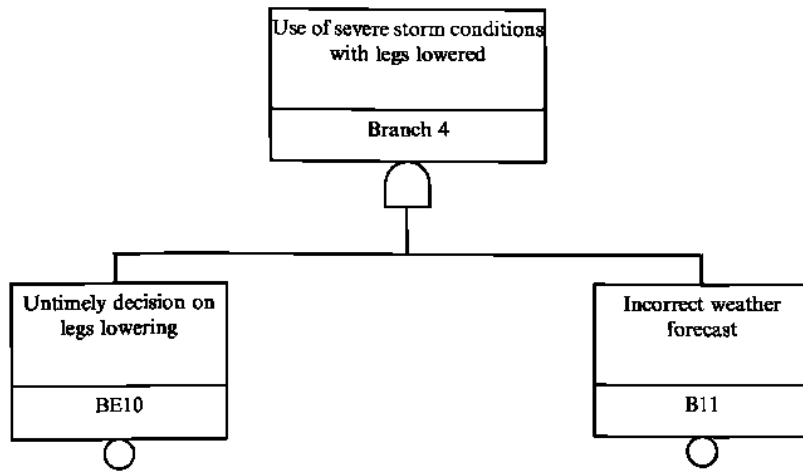

Continuation of error and fault tree construction

G branch symbols

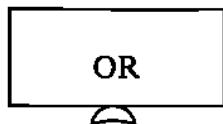

$G = A \text{ or } B \text{ or } C$
The branch is correct if any input is probable (we are dealing with a probability theory theorem).

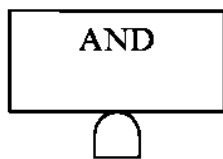

$G = A \text{ and } B \text{ and } C$
The branch is correct if all the events of inputs occur (we are dealing with a probability theory theorem).

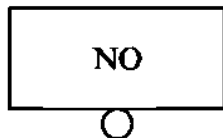

$G = \text{no } (A)$
3 out of N

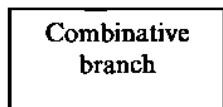

The branch is correct if any three out of all the events of inputs occur.

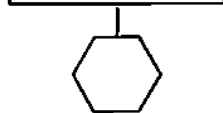

$G = \text{no } (A) \text{ or } B$

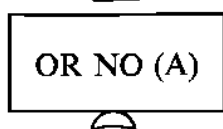

$G = A \text{ and no } (B)$

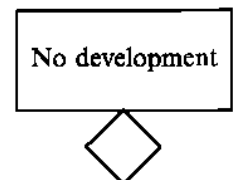
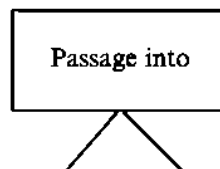
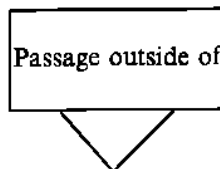
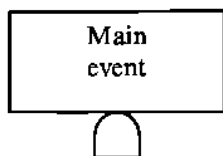
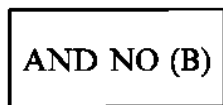

ERROR AND FAULT TREE

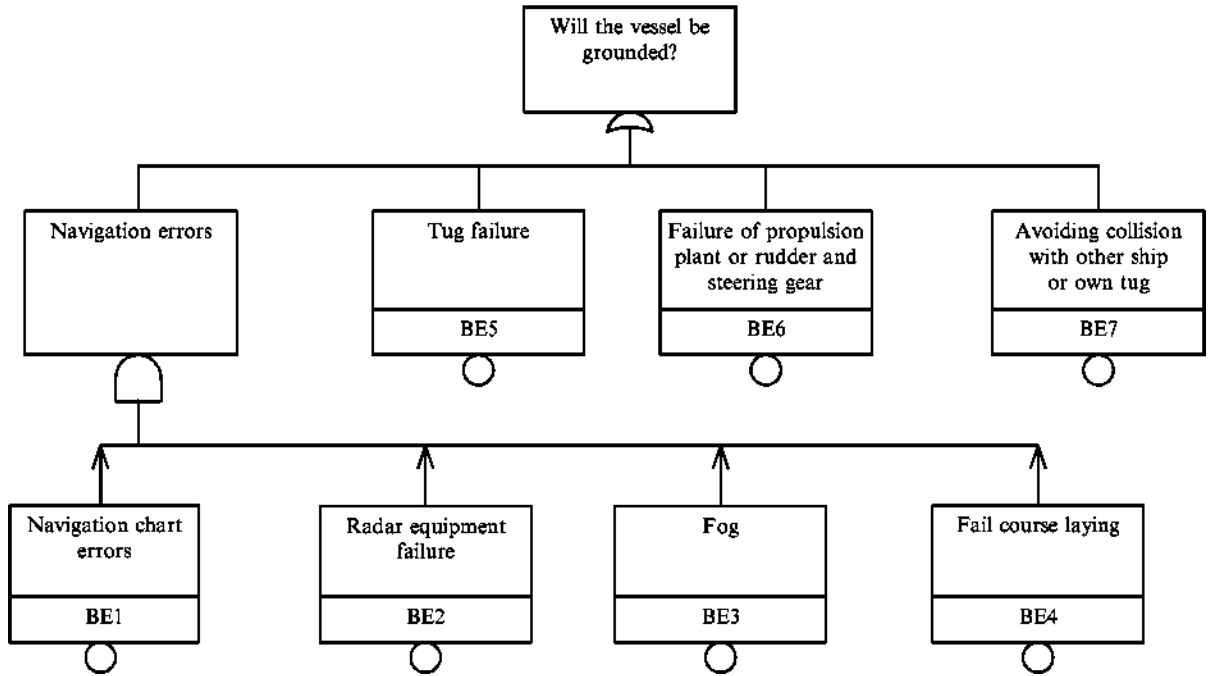

CONSTRUCTION OF FN CURVES

The FN curves relate to societal risk, not to individual. The societal risk testifies a catastrophe magnitude.

Example. Assume that the case in point is 10 fatalities on 5 platforms of the same type. These 10 fatalities could happen both on 5 platforms with two victims on each and on one platform where 10 people would die at once. For the hypothetical example of 10 fatalities under consideration, the following distribution is assumed (Table 1).

Table 1

Statistics of fatalities on platforms of one type

Platform	I	II	III	IV	V
Number of the dead (N)	2	1	1	4	2

The same data in Table 2 are presented in the form more suitable for the further analysis. Table 2 data allow to construct a graph with the horizontal axis N – "Number of fatalities", and the vertical axis F – "Frequency of accidents" in which at least N people have died (Fig).

Table 2

Frequency of fatalities and their distribution

Number of the dead N	Number of accidents in which N people have died	Frequency of accidents (number of cases per platform) in which N people have died	Number of accidents in which at least N people have died	Frequency of accidents (number of cases per platform) in which at least N people
1	2	$2/50 = 0,04$	5	$5/50 = 0,1$
2	2	$2/50 = 0,04$	3	$3/50 = 0,06$
3	0	$0/50 = 0$	1	$1/50 = 0,02$
4	1	$1,50 = 0,02$	1	$1/50 = 0,02$
5	0	$0,50 = 0$	0	$0/50 = 0$

The plots of the type in question are called FN diagrams. The societal risk is the integral characteristic of the consequences of certain kind hazards materialization.

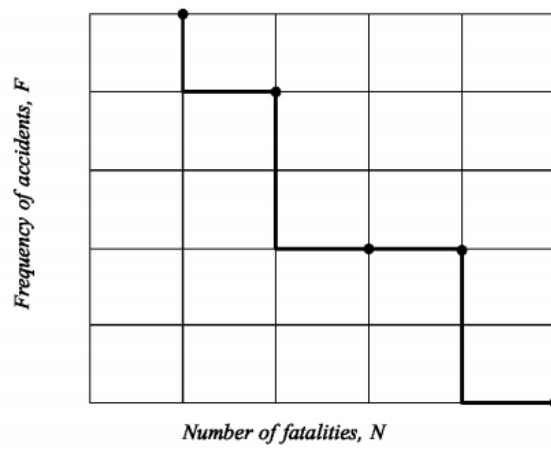

Fig.
Frequency of fatalities on platforms on which at least N people have died

**FORM OF PRESENTATION OF INFORMATION ON DAMAGES OF OFFSHORE
PLATFORM STRUCTURES OBTAINED IN ACCIDENT AND INSTRUCTION
FOR ITS FILLING**

**FORM OF PRESENTATION OF INFORMATION ON DAMAGES OF OFFSHORE
PLATFORMS STRUCTURES**

Section 1. General type of an offshore platform	
Section 2. Design number	
Section 3. Distinctive attributes of a specific structure	
3.1 Registered number	
3.2 Name of the structure	
3.3 Date built (updated)	
Section 4. Distinctive attributes of the organization that has presented information	
4.1 Name of the organization (Register Branch Office)	
4.2 Date of information presentation	
Section 5. General data about the object (description of a structure, material, draught, sea depth in a drilling position, etc.)	
Section 6. General description of an accident event and damages	
6.1 General diagram of a structure	
6.2 Damage types	
6.3 Date of an accident and its consequences	
6.4 Operational conditions when damages have happened	
6.5 Description of environmental conditions (if data are available)	
6.6 Platform position when damages have happened	
6.7 Probable causes of damages occurrence	
6.8 List of damaged structural elements	
6.9 General condition of the offshore platform after damage	
6.10 Water area pollution	
6.11 Casualties	
6.12 Other data	
Section 7. Description of damages (to be presented: the diagram of a damaged structural element, strength member dimensions required, damage dimensions, accompanying information, etc.); the number of pages is not regulated.	

INSTRUCTION FOR FILLING THE FORM

Section 1. General type of an offshore platform. The following designations are used.
Semi-submersible MODU – semi-submersible mobile offshore drilling unit.

Self-elevating MODU – self-elevating mobile offshore drilling unit.

FOP – fixed offshore platform.

Section 2. Design number.

No explanations are needed.

Section 3. Distinctive attributes of a specific structure.

No explanations are needed.

Section 4. Distinctive attributes of the organization that has presented the information.

No explanations are needed.

Section 5. General data about the object.

Structural particulars are presented:

list of hull components (hull structures);

their names, design and number (e.g. self-elevating MODU legs of the truss type – 4 pcs.);

main dimensions of the hull at large and characteristic dimensions of hull structures;

for FOP, the architectonic-constructive type (e.g. platform on legs, monopode, etc.), the way of keeping on the seabed.

The materials, of which platform structures are mainly fabricated, shall be specified.

The draught for various operating conditions shall be specified for mobile units, and the sea depth in a drilling position for FOP and self-elevating MODU.

In addition, the particulars of a clearance, ice strake and other features of a platform may be provided.

Section 6. General description of an accident event and damages.

6.1 General diagram of the structure.

To be stated whether the diagram is presented in Appendix to Form or not. The diagram is usually presented when the object is new, non-traditional or in other cases if necessary in the opinion of the organization completing the Form. The diagram may be presented as a three-dimensional sketch, in some projections showing damaged elements and areas, with numbering of structural elements, etc. for the better description of the structure and damages.

If the diagram is of no need in the opinion of the organization completing the Form, it may be lacking.

6.2 Damage types.

The following types are specified:

residual deformations;

break of integrity (cracks, ruptures, fractures);

other types due to platform structural features.

All the types of damages corresponding to a specific accident event shall be listed.

6.3 Date of the accident and its consequences.

No explanations are needed.

6.4 Operating conditions when damages have happened.

One of the following modes is specified:

transit;

positioning at a site;

operational conditions;

survival or extreme loading;

removal from site;

any other design mode of operation due to specific nature of a structure.

6.5 Description of environmental conditions (if data are available).

Data on the wave height, wind velocity, ice formations, seismic situation, air temperature, etc. are presented.

6.6 Platform position when damages have happened.

An operating area and a sailing route shall be, at least, specified.

6.7 Probable causes of damages occurrence.

The causes like the following may be specified:

extreme hydrometeorological conditions;

earthquakes;

collisions with ships and other floating objects;

dropped objects;

helicopter accident;

explosions;

fires;

blowouts;

seabed fluidization;

structure shifting or capsizing;

accumulation of fatigue damages;

mistakes in design and manufacture of a structure;

violation of the operating instruction requirements;

combination or the sequential chain of the above events resulting in damages;

other causes attributed to the specific nature of a structure.

6.8 List of structural elements damaged.

All damaged structural elements omitting the details of damaged areas shall be listed. For example, as applied to a self-elevating MODU:

leg elements, joints of a pontoon with an outrigger, helideck elements, etc.;

to a semi-submersible MODU:

support girders of the upper hull, horizontal bracings, stability columns, pontoons in way of a sheer strake, etc.

The description shall be rather general as the detailed description of damages will be given in [Section 7](#).

6.9 General condition of the offshore platform after damage.

The following shall be specified:

the platform has remained in operation without repair up to planned arrangements;

the repair has been carried out without platform removal from service;

the platform has been removed from service for repair, utilization, etc.

The clause may be supplemented with other items.

6.10 Water area pollution.

Shall be, at least, indicated: Yes or No.

6.11 Casualties.

No explanations are needed.

6.12 Other data, which are essential in the opinion of inspection services and the platform owner.

Section 7. Description of damages.

The description shall be brief, clear and, as far as possible, informative.

In this Section, it shall be detailed the damaged areas and damage types, presented the diagrams of damaged structural elements (where needed, in a certain order with reference to [6.1](#)), the dimensions (parameters) of damages, the necessary dimensions of structural elements; repair techniques and other appropriate information may be detailed as well.

All that attendant information, which is essential in the opinion of the organization completing the Form, shall be presented.

There is a good reason to highlight in some way the damage parameters in the text.

Russian Maritime Register of Shipping

**Rules for the Classification, Construction and Equipment of Mobile Offshore Drilling Units
and Fixed Offshore Platforms
Part XV
MODU and FOP Safety Assessment**

FAI "Russian Maritime Register of Shipping"
8, Dvortsovaya Naberezhnaya,
191186, St. Petersburg,
Russian Federation
www.rs-class.org/en/