

RULES

FOR THE CLASSIFICATION AND CONSTRUCTION OF SEA- GOING SHIPS

PART VII MACHINERY INSTALLATIONS

ND No. 2-020101-174-E



St. Petersburg

RULES FOR THE CLASSIFICATION AND CONSTRUCTION OF SEA-GOING SHIPS (PART VII)

The present version of Part VII "Machinery Installations" of the Rules for the Classification and Construction of Sea-Going Ships of Russian Maritime Register of Shipping (RS, the Register) has been approved in accordance with the established approval procedure and comes into force on 1 January 2026.

The present version is based on the version dated 1 July 2025 and Rule Change Notice No. 25-257378, taking into account the amendments and additions developed immediately before publication (refer to [the Revision History](#)).

REVISION HISTORY¹

For this version, there are no amendments to be included in the Revision History.

¹ With the exception of amendments and additions introduced by Rule Change Notices (RCN), as well as of misprints and omissions.

1 GENERAL

1.1 APPLICATION

1.1.1 The requirements of this Part of the Rules for the Classification and Construction of Sea-Going Ships¹ apply to ship machinery installations, equipment of machinery spaces, shafting lines, propellers, machinery condition monitoring systems, spare parts and active means of the ship's steering (refer to [7.1.1](#)).

In this case, requirements of [Sections 1 — 4](#) and [9](#) and recommendations of [Appendix 1](#) of the machinery installations and machinery space equipment on ships of gross tonnage less than 500, as well as the requirements of Part IX "Machinery" may be applied in so much as applicable and sufficient. It also refers to berth-connected ships.

The requirements for machinery installations of polar class ships (refer to 2.2.3.1, Part I "Classification") are set forth in Section 1, Part XVII "Distinguishing Marks and Descriptive Notations in the Class Notation Specifying Structural and Operational Particulars of Ships".

The requirements to machinery installations of Baltic ice class ships (refer to 2.2.3.1, Part I "Classification") are specified in Section 10, Part XVII "Distinguishing Marks and Descriptive Notations in the Class Notation Specifying Structural and Operational Particulars of Ships".

Note. List of minimum recommended spare parts is specified in [Appendix 1](#).

1.1.2 The requirements of this Part are set forth proceeding from the condition that the flash point of fuel oil (refer to 1.2, Part VI "Fire Protection") used in ships of unrestricted service for the engines and boilers is not below 60 °C and the flash point of fuel for emergency generator engines, not below 43 °C.

In ships certified for restricted service within areas having a climate ensuring that ambient temperature of spaces where such fuel oil is stored will not rise to within 10 °C below its flash point may use fuel oil with flash point not less than 43 °C. In this case, measures shall be taken to ensure checking and maintenance of the above condition.

The use of fuel having a flash point of less than 43 °C may be permitted for cargo ships only subject to the technical substantiation submitted to the Register.

Such fuel shall not be stored in any machinery space.

Crude oil and slops may be used as boiler fuel in oil tankers and oil tank barges. The conditions of such use are stated under 13.11, Part VIII "Systems and Piping".

On gas carriers for gas turbine engines and dual-fuel internal combustion engines it is allowed to use the natural gas (methane) carried as fuel. Conditions of application of natural gas as fuel are set out in 13.12, Part VIII "Systems and Piping" and in 8.10 and Section 9, Part IX "Machinery".

¹ Hereinafter referred to as "the RS Rules/C".

1.2 DEFINITIONS AND EXPLANATIONS

1.2.1 Definitions and explanations relating to general terminology of the RS Rules/C are given in Part I "Classification".

The following definitions, as adopted in this Part of the RS Rules/C, are equally applicable for the purpose of Part VIII "Systems and Piping" and Part IX "Machinery".

Shafting is a structural complex that kinematically connects ship's main machinery or the main gearing (if available) with a propeller including propeller, intermediate and other shafts complete with couplings and also a sterntube arrangement with bearings, seals, lubrication and cooling systems, other arrangements (e.g. the propeller shaft sag measuring gauges, protective covers, braking arrangement, etc.) and involved in transmitting torque from the engine to propeller.

Auxiliary active means of ship's steering is a propulsion and steering unit ensuring propulsion and steering of a ship at low speed or steering of a ship at zero speed when the ship is equipped with main means of propulsion and steering, and is used either in combination with the latter or when the main means of propulsion and steering are inoperative.

Auxiliary machinery is the machinery necessary for the operation of main engines, supply of the ship with electric power and other kinds of energy, as well as functioning of the systems and arrangements subject to survey by the Register.

Among the essential auxiliary machinery are:

a generating set, which serves as a main source of electrical power;

steam supply source;

condensate pump and arrangements used for maintaining vacuum in condensers;

the mechanical air supply for boilers;

an air compressor and receiver for starting or control purposes;

as well as machinery ensuring operation or functioning of:

boiler feed water systems;

the fuel oil supply systems for boilers or engines;

the sources of water pressure;

the hydraulic, pneumatic or electrical means for control in main propulsion machinery including controllable pitch propellers.

Exit is an opening in bulkhead or deck provided with closing means and intended for the passage of persons.

Means of escape comprise the escape routes leading from the lowest part of the machinery space floor plates to the exit from that space.

Main active means of ship's steering is a propulsion and steering unit being part of the propulsion plant.

Main machinery is the machinery being part of the propulsion plant.

Technical condition diagnosis is a process of establishing causes for the deviation of diagnostic parameters when performing condition monitoring and/or detecting malfunctions, as rules, by stripless methods in order to provide maintenance and repair on the actual condition basis.

Remote control is the changing of the speed and direction of rotation as well as starting and stopping of the machinery from a remote position.

Engine room is a machinery space intended for the main engines and, in the case of ships with electric propulsion plants, the main generators.

Machinery spaces are all machinery spaces of category A and all other spaces containing main machinery, shafting, boilers, fuel oil units, steam and internal combustion engines, generators and other major electrical machinery, fuel oil filling stations, ventilation and air-conditioning installations, refrigerating plants, steering engines, stabilizing equipment and similar spaces, and trunks to such spaces.

Machinery spaces of category A are those spaces and trunks to such spaces, which contain:

internal combustion machinery used for purposes other than main propulsion where such machinery has in the aggregate a total power output of not less than 375 kW; or

any oil-fired boiler or oil fuel unit, or any oil-fired equipment other than boilers, such as inert gas generators, incinerators, etc.

Local control station is a control station fitted with controls, indicators, means of communication (if necessary), located in proximity to, or directly on, the engine.

Torsional vibration stresses are stresses resulting from the alternating torque, which is superimposed on the mean torque.

Dead ship condition (as well as black out) is a condition, under which the main propulsion plant, boilers and auxiliaries are not in operation and in restoring the propulsion, no stored energy for starting the propulsion plant, the main source of electrical power and other essential auxiliaries shall be assumed available. It is assumed that means are available to start the emergency generator at all times.

Equipment comprises all types of filters, heat exchangers, tanks and other arrangements ensuring normal operation of a machinery installation.

Common control station is a control station intended for simultaneous control of two or several main engines and fitted with indicating instruments, alarm devices and means of communication.

Cargo control room (CCR) is a room or part thereof where the control, monitoring means and alarm devices, related to performance of cargo handling operations are located; and onboard the tankers, in addition, means for monitoring and alarm of cargo, ballast, atmosphere parameters of cargo and ballast tanks and cargo pump rooms as well as discharge of oil containing and flushing water.

Technical condition prediction is a process of determining causes for the changes in control item for the forthcoming time period, based on the trend of the diagnostic parameter values during the preceding time period.

Propulsion plant is the totality of machinery and arrangements intended for generating, converting and transmitting power ensuring propulsion of the ship at all specified rates of speed and comprising propellers, shafting, main gearing and main machinery, including electric propulsion motors.

Rated power means the maximum continuous (not time-limited) power adopted in calculations under these Rules and stated in documents issued by the Register.

Rated speed means the speed corresponding to the rated power.

Steering system is ship's directional control system, including main steering gear, auxiliary steering gear, steering gear control system and rudder if any (refer to 1.2.9, Part III "Equipment, Arrangements and Outfit").

Technical condition monitoring system is a complex of inspection facilities and actuators interacting with the control item on demand set forth by the appropriate documentation. The condition monitoring system provides for the identification of the type of the item technical condition and systematic observation (tracing) of its change on the basis of measurement of the controlled (diagnostic) parameters and comparison of these values with the set standards.

Active means of the ship's steering (AMSS) are special propulsion and steering units and any combinations of them or with the main propulsion devices, capable of producing thrust or traction force both at a fixed angle to the centre plane of the ship and at a variable angle, either under all running conditions (main AMSS) or part thereof including small and zero speed (auxiliary AMSS) (refer also to 1.2.8, Part III "Equipment, Arrangements and Outfit").

Fuel oil unit is any equipment used for the preparation and delivery of fuel oil (heated or unheated) to boiler, inert gas generator or engine (including gas turbines) and includes any fuel oil pumps, separators, filters and heaters at a pressure of more than 0,18 MPa.

Fuel oil transfer pumps are not considered as fuel oil units.

Main machinery control room is a space containing the remote controls of main and auxiliary machinery, CP-propellers, main and auxiliary AMSS, indicating instruments, alarm devices and means of communication.

Trend in diagnostic parameter (parameter trend) is a time history of the diagnostic parameter shown graphically or in other form (previous history of the parameter change).

1.3 SCOPE OF SURVEYS

1.3.1 General provisions covering the procedure of classification and surveys during construction and in service are stated in the General Regulations for the Classification and Other Activity and in Part I "Classification".

1.3.2 Survey by the Register, including the approval of technical documentation according to 3.2.7, Part I "Classification", shall cover the following parts and components:

.1 shafting as assembled, including propeller shaft with liners and waterproof coatings, shaft bearings, thrust blocks and sterntube bearings, couplings, sterntube seals;

.2 propellers, inclusive vertical-axis propellers and jets, steerable propellers, athwartship thrusters and propulsive systems of active rudders, pitch control units, oil distribution boxes and control systems of propellers;

.3 parts indicated in [Table 1.3.2.3](#).

1.3.3 Subject to survey by the Register is the assembling of the machinery space equipment and testing of the following components of the machinery installation:

.1 main engines with reduction gears and couplings;

.2 boilers, heat exchangers and pressure vessels;

.3 auxiliary machinery;

.4 control, monitoring and alarm systems of the machinery installation;

.5 shafting and propellers;

.6 active means of the ship's steering.

1.3.4 After assembling of machinery, equipment, systems and piping arrangements on board the ship, the machinery installation shall be tested in operation under load according to the program approved by the Register.

Table 1.3.2.3

Parts to be surveyed

| Nos | Item | Material | Chapter of Part XIII "Materials" |
|----------|---|---------------------------|----------------------------------|
| 1 | Shafting | | |
| 1.1 | Intermediate, thrust and propeller shafts | Forged steel | 3.7 |
| 1.2 | Propeller shaft liners | Copper alloy | 4.1 |
| | | Corrosion-resistant steel | On agreement with the Register |
| 1.3 | Half-couplings | Forged steel | 3.7 |
| | | Cast steel | 3.8 |
| 1.4 | Coupling bolts | Forged steel | 3.7 |
| 1.5 | Stern tubes | Rolled steel | 3.2 |
| | | Cast steel | 3.8 |
| | | Forged steel | 3.7 |
| | | Cast iron | 3.9 |
| 1.6 | Stern tube and strut bushes | Cast steel | 3.8 |
| | | Copper alloy | 4.2 |
| | | Forged steel | 3.7 |
| | | Cast iron | 3.9, 3.10 |
| 1.7 | Lining of stern bush bearing | Non-metallic materials | On agreement with the Register |
| | | Metal alloys | |
| 1.8 | Thrust block casing | Rolled steel | 3.2 |
| | | Cast steel | 3.8 |
| | | Cast iron | 3.9 |
| 2 | Propellers | | |
| 2.1 | Solid propellers | Cast steel | 3.12 |
| | | Copper alloy | 4.2 |
| 2.2 | Built propellers | | |
| 2.2.1 | Blades | Cast steel | 3.12 |
| | | Copper alloy | 4.2 |
| 2.2.2 | Boss | Cast steel | 3.12 |
| | | Copper alloy | 4.2 |
| 2.2.3 | Bolts (studs) for securing of blades, hub cones and seals | Copper alloy | 4.1 |
| | | Stainless steel | 3.16 |
| 2.3 | Hub cones | Cast steel | 3.12 |
| | | Copper alloy | 4.1, 4.2 |
| 2.4 | CPP crosshead in Arc4 — Arc9 ice class ships and icebreakers | Forged steel | 3.7 |
| | | Cast steel | 3.8 |
| 2.5 | Casings of main AMSS in Arc4 — Arc9 ice class ships and icebreakers | Forged steel | 3.7 |
| | | Cast steel | 3.8 |
| | | Rolled Steel | 3.2 |

Notes: 1. The materials shall be selected in accordance with [2.4](#).
 2. All shafts (propeller, thrust, intermediate), propeller blades shall be subjected to non-destructive testing when manufactured. The methods, standards and scope of such tests shall be agreed with the Register.
 3. The nomenclature and material of the CPP components: crank pin rings, sliding shoes (other than those given under item [2.4](#)), push-pull rods; hydraulic cylinders, etc., as well as the AMSS parts (other than those given under item [2.5](#)) shall be agreed with the Register.

2 GENERAL REQUIREMENTS

2.1 POWER OF MAIN MACHINERY AND GENERAL TECHNICAL REQUIREMENTS

2.1.1 The requirements to power at the propeller shafts of icebreakers and ice class ships are specified in [2.1.1.1 — 2.1.1.4](#) depending on their ice class.

2.1.1.1 The power at icebreaker propeller shafts shall be substantiated and correspond to their ice class in compliance with 2.2.3, Part I "Classification".

2.1.1.2 The minimum required power delivered to the propeller shaft of ships of ice classes **Ice2** and **Ice3** shall not be less than bigger of the values determined according to [2.1.1.3](#) and [2.1.1.4](#).

The minimum required power delivered to the propeller shaft of ice ships of arctic category Arc4 shall not be less than the lesser of values determined according to [2.1.1.3](#) and [2.1.1.4](#).

The minimum required power delivered to the propeller shaft of ships of ice classes **Arc5** to **Arc9** shall be determined according to [2.1.1.3](#).

2.1.1.3 Power P_{min} , in kW, shall be determined by the formula

$$P_{min} = f_1 f_2 f_3 (f_4 \Delta + P_0), \quad (2.1.1.3)$$

where $f_1 = 1,0$ – for fixed pitch propellers;
 $f_1 = 0,9$ – for propulsion plants with controllable pitch propellers or electric drive;
 $f_2 = \varphi/200 + 0,675$, but not more than 1,1;
 φ = slope of stem (refer to 3.10.1.2, Part II "Hull");
 $f_2 = 1,1$ for a bulbous stem; the product $f_1 f_2$ shall be taken in all cases not less than 0,85;
 $f_3 = 1,2B/\sqrt[3]{\Delta}$, but not less than 1,0;
 B = breadth of the ship, m;
 Δ = ship's displacement to the summer load waterline (refer to 1.2.1, Part III "Equipment, Arrangements and Outfit"), t. When calculating for ships of ice classes **Ice2** and **Ice3** Δ need not be taken more than 80000 t;
 f_4 and P_0 are given in [Table 2.1.1.3](#).

Table 2.1.1.3

| Displacement Δ , t | Value | Ice class ships | | | | | | | |
|------------------------------|------------|-----------------|-------------|-------------|-------------|-------------|-------------|-------------|-------------|
| | | Ice2 | Ice3 | Arc4 | Arc5 | Arc6 | Arc7 | Arc8 | Arc9 |
| $\Delta < 30000$ | f_4 | 0,18 | 0,22 | 0,26 | 0,3 | 0,36 | 0,42 | 0,47 | 0,5 |
| | P_0 , kW | 0 | 370 | 740 | 2200 | 3100 | 4000 | 5300 | 7500 |
| $\Delta \geq 30000$ | f_4 | 0,11 | 0,13 | 0,15 | 0,2 | 0,22 | 0,24 | 0,25 | 0,26 |
| | P_0 , kW | 2100 | 3070 | 4040 | 5200 | 7300 | 9400 | 11600 | 14700 |

Irrespective of the results obtained in calculating the power as per Formula ([2.1.1.3](#)), the minimum power, in kW, shall not be less than:

- 10000 kW for **Arc9** ice class ships;
- 7200 kW for **Arc8** ice class ships;
- 5000 kW for **Arc7** ice class ships;
- 3500 kW for **Arc6** ice class ships;
- 2600 kW for **Arc5** ice class ships;
- 1000 kW for **Ice2** and **Ice3** and **Arc4** ice class ships.

2.1.1.4 The power P_{min} , in kW, shall be determined as the maximum value calculated for the upper (UIWL) and lower ice waterlines (LIWL) as indicated in 1.1.3, Part XVII "Distinguishing Marks and Descriptive Notations in the Class Notation Specifying Structural and Operational Particulars of Ships" as per the formula

$$P_{min} = K_e \frac{(R_{CH}/1000)^{3/2}}{D_p} \quad (2.1.1.4-1)$$

where K_e = coefficient given in [Table 2.1.1.4-1](#);
 R_{CH} = parameter determined as per the formula

$$R_{CH} = 845C_\mu(H_F + H_M)^2(B + C_\psi H_F) + 42L_{PAR}H_F^2 + 825(LT/B^2)^3 \frac{A_{wf}}{L} \quad (2.1.1.4-2)$$

where $C_\mu = 0,15\cos\varphi_2 + \sin\psi \sin\alpha$, but not less than 0,45;

$$H_F = 0,26 + (H_M B)^{0,5};$$

$$H_M = 1,0 \text{ for Arc4 ice class ships};$$

$$H_M = 0,8 \text{ for ships of ice class Ice3};$$

$$H_M = 0,6 \text{ for ships of ice class Ice2};$$

$$B = \text{breadth of the ship, m};$$

$$C_\psi = 0,047\psi - 2,115; C_\psi = 0 \text{ at } \psi < 45^\circ;$$

$$L_{PAR} = \text{length of the parallel midship body, m};$$

$$L = \text{length of the ship between the perpendiculars, m};$$

$$T = \text{draught at UIWL or LIWL, m};$$

$$A_{wf} = \text{area of the waterline of the bow, m}^2;$$

$$\alpha = \text{angle of the waterline at B/4, degree};$$

$$\varphi_1 = \text{rake of the stem at the centreline, degree};$$

$$\varphi_1 = 90^\circ \text{ for a ship with a bulbous bow};$$

$$\varphi_2 = \text{rake of the bow at B/4, degree};$$

$$\psi = \arctan(\tan\varphi_2/\sin\alpha);$$

$$D_p = \text{diameter of the propeller, m};$$

$$L_{BOW} = \text{length of the bow, m}.$$

If the value $(LT/B^2)^3$ is less than 5, than the value is assumed equal to 5. If the value $(LT/B^2)^3$ is more than 20, than the value is assumed equal to 20.

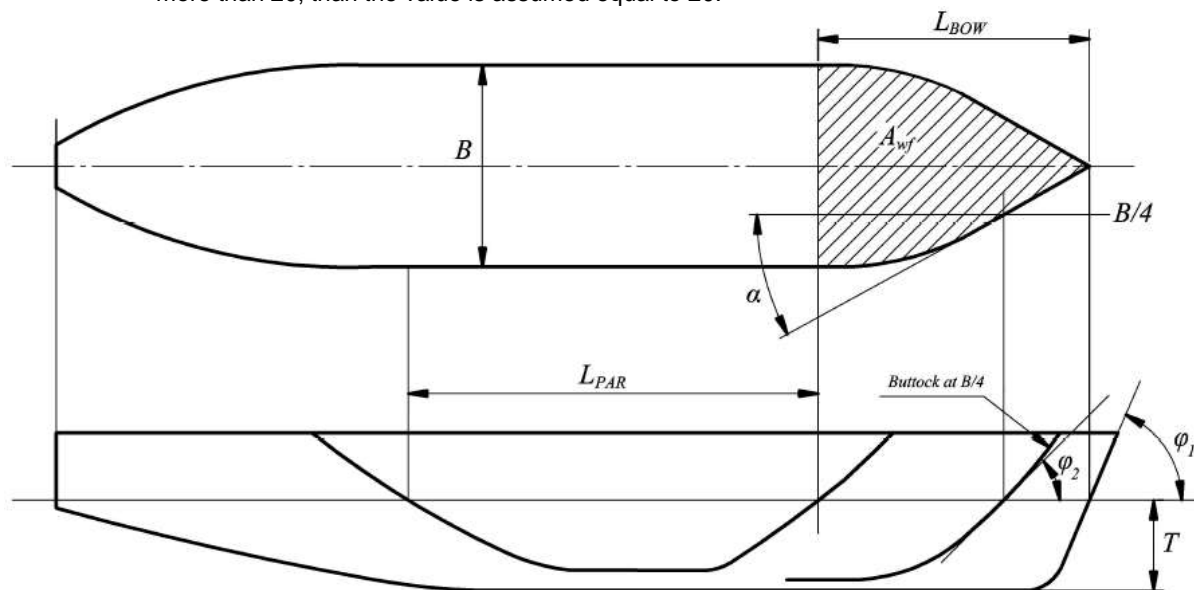

Fig. 2.1.1.4

Geometrical features of the ship for determination of the power delivered to the propeller shaft of ice class ships

Table 2.1.1.4-1

Values of coefficient K_e

| Number of propellers | Propulsion plant with controllable pitch propeller or electric drive | Propulsion plant with fixed pitch propeller |
|----------------------|--|---|
| 1 | 2,03 | 2,26 |
| 2 | 1,44 | 1,60 |
| 3 | 1,18 | 1,31 |

2.1.1.5 The minimum power values may be reduced subject to the technical substantiation submitted to the Register in each particular case.

2.1.2 In icebreakers and **Arc6** — **Arc9** ice class ships, turbines and internal combustion engines with mechanical transmission of power to the propeller may be utilized as main engines, provided use is made of the devices to protect turbines, reduction gears of gas-turbine geared sets and diesel-engine geared sets against the loads exceeding the design torque determined with regard to operation of such ships under ice conditions in compliance with the requirements of 4.2.3.2, Part IX "Machinery".

2.1.3 Propulsion plant shall provide sufficient astern power to maintain manoeuvring of the ship in all normal service conditions.

2.1.4 The minimum astern power shall be determined by the ship designer and shall not exceed the maximum permissible astern power (MPAP) for which the propulsion plant is designed. Astern trials are to be conducted in accordance with the provisions of ISO 19019:2005, Section 5.4: Astern trials.

The astern tests shall be carried out from control positions. A test program shall be provided by the yard and accepted by RS. If specific operational characteristics have been defined by the manufacturer these shall be included in the test program.

2.1.5 In propulsion plants with reversing gears or CP-propellers as well as in electric propulsion plants, precautions shall be taken against possible overload of main engines in excess of permissible values, including MPAP.

The designed maximum astern power defining the maximum astern speed for the design of the main steering gear and rudder stock as per chapter 2 of Part III "Equipment, Arrangements and Outfit" and UR S10.2.1.1 (IACS unified requirement (UR) S10, the document is available at the IACS website: www.iacs.org.uk), shall not to be taken less than the MPAP.

2.1.6 Means shall be provided to ensure that the machinery may be brought into operation from the dead ship condition without external aid (refer to 16.2.3, Part VIII "Systems and Piping").

On ships where internal combustion engines are started by compressed air, the set of equipment for starting shall ensure the supply of air in quantity sufficient for the initial start without external aid.

Where the ship is not fitted with an emergency generator, or an emergency generator does not comply with the requirements specified under 2.9.4, Part IX "Machinery", the means for bringing main and auxiliary machinery into operation shall be such that the initial charge of starting air or initial electrical power and any power supplies for engine operation can be developed on board ship without external aid. If for this purpose an emergency air compressor or an electric generator is required, the machinery shall be powered by a hand-starting ICE or a hand-operated compressor.

The emergency generator and other means needed to restore the propulsion shall have a capacity such that the necessary propulsion starting energy is available within 30 min of black out/dead ship condition (refer to [1.2](#)).

Emergency generator stored starting energy shall not be directly used for starting the propulsion plant, the main source of electrical power and/or other essential auxiliaries (emergency generator excluded).

For steam ships, the 30 min time limit may be interpreted as time from black out/dead ship condition to light-off of the first boiler.

2.1.7 In the event of failure of one or all turbochargers (refer to 2.5.1, Part IX "Machinery") the machinery installation with one main internal combustion engine shall provide the ship speed at which the steerability of the ship is maintained. The main engine shall provide not less than 10 per cent of the rated power.

2.1.8 The power of main machinery in ships of river-sea navigation shall provide the ahead speed in load condition of at least 10 knots in calm water. Another speed may be set for the ships intended for navigation in geographically restricted areas while providing sufficient speed to maintain the ship's handling capability in load condition.

2.1.9 Supercharged high-speed engines (over 1400 rpm), which increased noise level makes direct local control difficult, may be admitted by the Register for use as main engines in sea-going ships, if provision is made for remote control and monitoring so that constant presence of the attending personnel in the engine room will not be necessary.

The control and monitoring facilities shall comply with the requirements of Part XV "Automation".

2.1.10 In the case of ships with twin hulls, the failure of the machinery installation of one hull will not put the machinery installation of the other hull out of action.

2.1.11 Long run of the propulsion plant at all specified rates during its operation under the conditions corresponding to the assigned class shall not lead to the overload. Technically substantiated power supply shall be provided.

2.1.12 Propulsion plants and auxiliary machinery of passenger ships having length, as defined in 1.2.1 of the Load Line Rules for Sea-Going Ships¹, of 120 m or more or having three or more main vertical zones, shall comply with the requirements of 2.2.6.7.1 and 2.2.6.8, Part VI "Fire Protection".

2.1.13 For a ship with gas engines installed in an ESD (emergency shutdown devices)-protected machinery space, the minimum power of the main and auxiliary engines shall be assessed on a case-by-case basis from the operational characteristics of the ship, ensuring that the requirements of para 9.12.2.5, Part IX "Machinery" are met, taking into account the design and purpose.

2.1.14 For a ship with a single gas engine, the requirements of paras 9.12.2.7 — 9.12.2.8, Part IX "Machinery" shall be met. The minimum power shall be determined to ensure that this requirement is fulfilled, taking into account the particular design and purpose of the ship.

2.1.15 On icebreakers of ice class mark **Icebreaker7** — **Icebreaker9** and ships of unrestricted service of ice classes **Arc7** — **Arc9**, propellers (as a rule, four-bladed) with detachable blades shall be used. In this case, the ships shall be provided with technical means for replacing defective blades, the list of which is agreed by the Register (for example, means of launching / lifting, fastening and orientation of the blade), to replace defective blades afloat.

2.1.16 On icebreakers and ships of ice classes **Arc7** — **Arc9**, technical means shall be provided for complete shaft line turning of the shafting during the ship stay in close floating ice.

2.1.17 Propulsion plant of icebreakers and ships of ice classes **Arc6** — **Arc9** shall be capable of maintaining the rated power and required rated torque at propeller shafts in a range of rotation speed corresponding to the appropriate operating conditions in accordance with the assigned ice class.

¹ Hereinafter referred to as the RS Rules/LL.

2.2 NUMBER OF MAIN BOILERS

2.2.1 In general, not less than two main boilers shall be fitted in ships of unrestricted service. Using a steam power plant with one main boiler may be permitted provided the technical substantiation is submitted to the Register.

2.3 ENVIRONMENTAL CONDITIONS

2.3.1 The machinery, equipment and systems installed in the ship shall remain operative under environmental conditions stated in [Table 2.3.1-1](#) and [2.3.1-2](#), unless provided otherwise in the other parts of the RS Rules/C.

Sea water temperature is assumed to be equal to 32 °C. For ships designed for geographically restricted service other temperatures may be adopted if technical substantiation is available.

Table 2.3.1-1

List, motions and trim ^{1,2}

| Machinery and equipment | Steady list either way under static conditions | List either way under dynamic conditions (rolling) | Steady trim by bow or stern | Dynamic inclination by bow or stern (pitching) |
|---|--|--|-----------------------------|--|
| Main and auxiliary machinery | 15,0 | 22,5 | 5,0 ³ | 7,5 |
| Emergency machinery and equipment (emergency power installations, emergency fire pumps and their devices) | 22,5 ⁴ | 22,5 ⁴ | 10,0 | 10,0 |

¹ Steady list and trim shall be taken into account simultaneously. Rolling and pitching are also to be considered simultaneously.
² On agreement with the Register, the values of inclinations may be altered depending on the type and dimensions of the ship and its service conditions as well.
³ Where the length of the ship exceeds 100 m, the static trim by bow or stern may be taken as $(500/L)^\circ$ where L is the length of the ship, in m, as defined in 1.1.3, Part II "Hull".
⁴ In gas carriers, chemical tankers and chemical tank barges emergency power sources shall remain operative when the ship is listed up to 30 deg.

Table 2.3.1-2

Ambient temperature

| Installed location | Temperature range, °C |
|---|--|
| In enclosed spaces | 0 to + 45 |
| Spaces subject to temperatures exceeding 45 °C and below 0 °C | According to specific local conditions |
| On the open deck | -25 to + 45 |

Note. For ships intended for geographically restricted service other temperatures may be adopted on agreement with the Register.

2.3.2 Main propulsion and steering machinery and auxiliary machinery that are essential to the propulsion and steering, and the safety of the ship shall be capable of operation under the effects of acceleration and motions.

2.3.3 The requirements in [2.3.5 — 2.3.7](#) apply where documented evidence of equipment suitability is specifically required by the Register rules.

2.3.4 For ships subject to the requirements of SOLAS -74, ship builders shall identify and document the ship accelerations and motions periods to which machinery and equipment might be subjected to. The expected accelerations and ship motions periods shall comply within machinery and equipment manufacturers requirements. The estimations shall take into account the ship type, machinery or equipment location and expected service conditions.

2.3.5 Machinery and equipment manufacturers shall submit evidence to the Register that their machinery or equipment can operate under the required static and dynamic

conditions stated in [2.3.1](#) and at least at the levels of shipboard accelerations as stated in [2.3.4](#) and/or specified in the relevant RS requirements. Documentation of satisfactory performance shall take the form of:

- .1 Report of testing under representative conditions; or
- .2 Report of theoretical verification using recognised computational techniques accompanied by detailed and relevant validation data; or
- .3 Historical data which provides relevant demonstration of satisfactory experience in service.

2.3.6 Machinery and equipment manufacturers shall submit details of the requirements/recommendations for installation of the machinery and equipment onboard to ensure satisfactory operation in service under the required static and dynamic conditions as described in [2.3.1](#) and at least at the levels of shipboard accelerations as stated in [2.3.4](#) and/or specified in the relevant RS requirements.

Note: Consideration shall be given for positioning machinery in order to minimize the dynamic load on bearings due to ship motion.

2.3.7 Shipbuilders shall submit details demonstrating that the installation of the machinery and equipment onboard is in accordance with manufacturer's requirements/recommendations.

2.4 MATERIALS AND WELDING

2.4.1 Materials for the manufacture of parts of the shaftings and propellers shall comply with the requirements given in the relevant Chapters of Part XIII "Materials", as indicated in column 4, [Table 1.3.2.3](#). The materials used for the components stated in items [1.2—1.8](#), [2.2.3](#), [2.3—2.5](#) in [Table 1.3.2.3](#), may also be chosen in accordance with the relevant standards. In such a case, the application of materials shall be agreed with the Register when examining the technical documentation.

2.4.2 Intermediate, thrust and propeller shafts shall generally be made of steel with tensile strength R_m between 400 and 800 MPa.

It is allowed to manufacture the central sections of intermediate shafts and couplings from Fiber-Reinforced Plastic: fiber glass and carbon fiber.

2.4.3 The mechanical properties and chemical composition of materials used for the manufacture of propellers shall be in compliance with 3.12 and 4.2, Part XIII "Materials". Whereas steel of martensitic grade is permitted for the manufacture of propellers for ships of all types, steel of austenitic grade is permitted for the manufacture of propellers for ships without ice strengthening. The possibility to use carbon steel for the manufacture of propellers shall be agreed with the Register considering the requirements of 3.8, Part XIII "Materials".

Copper alloys of Type CU3 and Type CU4 are admitted for propellers in all ships, except icebreakers and **Arc7 — Arc9** ice class ships; copper alloys of Type CU1 and Type CU2 may be used exclusively for propellers in ships not having ice classes and in ships of ice classes **Ice1 — Ice3**.

2.4.4 Where it is intended to make shafting and propellers of alloy steels, including corrosion-resistant and high strength steels, data on chemical composition, mechanical and special properties, confirming suitability of the steel for intended application, shall be submitted to the Register.

2.4.5 Intermediate, thrust and propeller shafts as well as coupling bolts (studs) may be made of rolled steel in accordance with 3.7.1, Part XIII "Materials".

2.4.6 Securing and locking items of propeller blades, hub cones, stern tubes, stern bushes and sealings shall be made of corrosion-resistant materials.

2.4.7 Welding procedure and non-destructive testing of welded joints shall comply with the requirements of Part XIV "Welding".

2.4.8 For all ships, new installation of materials which contain asbestos shall be prohibited in machinery installations, machinery and equipment covered by the requirements of Part VI "Fire Protection", Part VII "Machinery Installations", Part VIII "Systems and Piping", Part IX "Machinery", Part X "Boilers, Heat Exchangers and Pressure Vessels" and Part XII "Refrigerating Plants".

2.5 INDICATING INSTRUMENTS

2.5.1 All the indicating instruments, with the exception of liquid-filled thermometers, shall be checked by competent bodies.

Pressure gauges fitted on boilers, heat exchangers, pressure vessels and refrigerating plants shall meet the requirements of 3.3.5 and 6.3.8, Part X "Boilers, Heat Exchangers and Pressure Vessels" and 7.1, Part XII "Refrigerating Plants", respectively.

2.5.2 The tachometer accuracy shall be within +2,5 %. With restricted speed ranges, the accuracy shall not be below 2 %, and the ranges shall be marked with bright colour on the scales of tachometers or in another way.

2.6 APPLICATION OF THE RELIABILITY MEASURES OF THE MACHINERY INSTALLATIONS

2.6.1 The reliability measures are established and specified during design and/or order of the machinery installation components by agreement of the appropriate technical documentation between the customer (shipowner) and the designer or supplier. The specific list of the reliability measures to be determined shall be established for each type of products with regard to the peculiarities of its application, failure effects, maintenance and repair system adopted.

3 CONTROL DEVICES AND STATIONS. MEANS OF COMMUNICATION

3.1 CONTROL DEVICES

3.1.1 Main and auxiliary machinery essential for the propulsion, control and safety of the ship shall be provided with effective means for its operation and control. All control systems essential for the propulsion, control and safety of the ship shall be independent or so designed that failure of one of them does not degrade the performance of another.

3.1.2 The starting and reversing arrangements shall be so designed and placed that each engine can be started or reversed by one operator.

3.1.3 Proper working direction of control handles or handwheels shall be clearly indicated by arrows and relevant inscriptions.

3.1.4 The setting of manoeuvring handle in the direction from, or to the right of, the operator, or turning the handwheel clockwise, when controlling the main engines from the navigation bridge, shall correspond to the ahead speed direction of the ship.

In the case of control stations, from which only the stern is visible, such a setting shall correspond to the direction of astern speed of the ship.

3.1.5 Control arrangements shall be so designed as to eliminate the possibility of spontaneously changing the positions prescribed.

3.1.6 The control devices of main engines shall have an interlocking system to preclude starting of the main engine, with a mechanical shaft-turning gear engaged.

3.1.7 It is recommended to provide an interlocking system between the engine-room telegraph and the reversing and starting arrangements so as to prevent the engine from running in the direction opposite to the prescribed one.

3.1.8 The main engine remote control system, with control from the bridge, shall be designed so as to provide an alarm in the event of failure. As far as practicable, the present propeller speed and thrust direction shall remain unchanged until control is transferred to a local station. Among other factors, the loss of power supply (electric, pneumatic or hydraulic power) shall not substantially affect the power of main engines or change the direction of propeller rotation.

3.1.9 The propulsion machinery remote control system with control from the wheel house shall be independent from the other order transmission system; however, one manoeuvring handle for systems may be accepted.

3.1.10 It shall be possible to control the propulsion machinery from the local control station, in the event of a failure of any unit of the remote control system.

3.1.11 For ships of river-sea navigation the duration of reversing (a period of time from the reversing of a steering control to the beginning of propeller operation with a thrust opposite in direction) shall not exceed:

25 s at full speed;

15 s at slow speed;

depending on the ship's speed.

3.2 CONTROL STATIONS

3.2.1 The bridge control stations of main engines and propellers, as well as the main machinery control room, with any type of remote control, shall be equipped with:

.1 controls for the operation of main engines and propellers. For installations comprising CP-propellers, vertical axis and similar type propellers, the navigation bridge may be equipped with means for remote control of propellers only. In such case, the alarm for low pressure of starting air, prescribed by [3.2.1.10](#), need not be provided;

.2 shaft speed and direction indicators if a fixed pitch propeller is installed; shaft speed and blade position indicators if the controllable pitch propeller is installed; main engines speed indicator if the disengaging coupling is provided;

.3 indicating means to show that the main machinery and remote control systems are ready for operation;

.4 indicating means to show which station is in control of the main propulsion machinery;

.5 means of communication (refer to [3.3](#));

.6 main engine emergency stop device, independent of the control system.

If disengaging couplings are provided for disconnection of main machinery from propellers, it is permissible that emergency shut-off of these couplings only is effected from the navigation bridge;

.7 device to override the automatic protection covering full range of parameters except those parameters which being exceeded, may result in serious damage, complete failure or explosion;

.8 indication for the override operation, alarms for activation of protection devices and the emergency stop;

.9 alarm for minimum oil pressure in pitch control system; overload alarm where the main engine operates with a CP-propeller, unless the recommendation of [6.5.3](#) is fulfilled;

.10 alarm for low starting air pressure, set at a level which still permits three starting attempts of reversible main engines duly prepared for operation.

.11 device to remote shut-off fuel oil supply to each engine for multi-engine installations in case where the fuel oil is supplied to all the engines from a single supply source (refer to 13.8.3.2, Part VIII "Systems and Piping");

.12 speed repeater (with due regard to 3.7.3.6, Part V "Navigational Equipment" of the Rules for the Equipment of Sea-Going Ships¹).

3.2.2 The control stations on the wings of navigation bridge shall be equipped with devices of waterproof construction with controlled illumination. The control stations provided on the wings of the navigation bridge need not meet the requirements of [3.2.1.3](#), [3.2.1.5](#), [3.2.1.7](#) — [3.2.1.10](#).

3.2.3 The emergency stop devices of main engine and the overrides of automatic controls shall be so constructed that inadvertent operation of such devices is not possible.

3.2.4 For the installations which consist of several main engines driving a single shafting, there shall be provided a common control station.

3.2.5 With a remote control system in use, provision shall also be made for local control stations of main machinery and propellers. Where, however, mechanical linkage is fitted for remote-controlling the main engine, the local control stations may be dispensed with on agreement with the Register.

3.2.6 Remote control of main machinery and propellers shall be performed only from one location. The transfer of control between the navigation bridge and engine room shall be possible only in the engine room and the main machinery control room. The means of transfer shall be so designed as to prevent the propelling thrust from altering significantly.

¹ Hereinafter referred to as the RS Rules/E.

Where the control stations are arranged on the wings of navigation bridge, the remote control of the main machinery shall be possible from one control station only. Such control stations may be equipped with interconnected controls.

3.2.7 Main engines shall be remotely operated from the wheelhouse by means of a single control element per propeller. In installations with CP-propellers, systems with two control elements may be used.

3.2.8 The sequence of the main engine operation modes assigned from the wheelhouse, including reversal from the full ahead speed in case of emergency, shall be controlled with the time intervals admissible for main engines. The modes assigned shall be indicated at the main machinery control room and at the local control stations of the main machinery.

3.2.9 Main machinery control rooms of floating docks shall comprise the following equipment:

- .1 controls of the pumps, including the suction and overboard discharge valves of ballast system;
- .2 recording devices for heel, trim and deflection control of the dock;
- .3 signals indicating the operation of pumps and the position ("open", "closed") of suction and discharge valves of the ballast system;
- .4 alarms on limit values of list and trim;
- .5 water level indicators of ballast compartments;
- .6 dock's communication facilities.

3.2.10 CCR shall be located as far from the machinery spaces as practicable. Onboard the tankers the CCR shall be arranged according to 2.4.9, Part VI "Fire Protection".

Furthermore, arrangement of CCR onboard chemical tankers and chemical tank barges shall comply with the requirements of Section 3, Part II "Structure of Chemical Tanker" of the Rules for the Classification and Construction of Chemical Tankers¹, and on ships intended for the carriage of liquefied gases in bulk - the requirements of Section 10, Part VI "Systems and Piping" of the Rules for the Classification and Construction of Ships Carrying Liquefied Gases in Bulk².

3.2.11 If CCR is provided on board the ship with assigning the distinguishing mark CCO (refer to 2.2.19, Part I "Classification") added to the character of classification, besides compliance with the requirements of [3.2.10](#), CCR shall be equipped with:

- .1 means of communication according to [3.3.2](#);
- .2 control means of:
 - .2.1 cargo, stripping and ballast pumps;
 - .2.2 fans servicing cargo area spaces or cargo holds;
 - .2.3 remotely controlled valves of cargo and ballast systems;
 - .2.4 hydraulic system pumps (if provided);
 - .2.5 inert gas system;
 - .2.6 pumps and valves of heeling system (if provided);
- .3 means for monitoring of:
 - .3.1 pressure in cargo manifolds;
 - .3.2 pressure in the manifold for vapour emission system (if provided);
 - .3.3 temperature in cargo and settling tanks;
 - .3.4 temperature and pressure of warming medium in the cargo heating system;
 - .3.5 actual value of ship's heel, trim and draught;
 - .3.6 actual value of level in the cargo and ballast tanks;
- .4 alarm devices on:
 - .4.1 fire alarm;

¹ Hereinafter referred to as the Chem Rules.

² Hereinafter referred to as the LG Rules.

- .4.2 exceeding of cargo temperature in cargo holds;
 - .4.3 high and low levels in cargo, ballast and settling tanks;
 - .4.4 extreme high level in cargo tanks;
 - .4.5 exceeding of permissible pressure in cargo manifolds of vapour emission system (80 per cent of pressure for actuating of high-velocity devices);
 - .4.6 exceeding the permissible fuel oil content in the discharge ballast and flushing water;
 - .4.7 exceeding the permissible temperature of pump casing according to 5.2.6, Part IX "Machinery";
 - .4.8 increasing of gland and bearing temperature at bulkhead penetrations of pump shafts as per [4.2.5](#);
 - .4.9 availability of cargo in segregated ballast tanks (for chemical tankers and chemical tank barges);
 - .4.10 increasing of level in the bilge ways of cargo pump rooms;
 - .4.11 parameters of inert gas system in compliance with 9.16.7.6, Part VIII "Systems and Piping";
 - .4.12 status of technical aids stipulated in [3.2.10](#);
 - .4.13 low water level in deck water seal (refer to 9.16.5, Part VIII "Systems and Piping").
- 3.2.12** In ships carrying liquid gas in bulk, means for monitoring and alarm shall be additionally provided in CCR to meet the requirement of Part VIII "Instrumentation" of the LG Rules.
- 3.2.13** In ships carrying dangerous chemical cargo in bulk, the signalling shall be additionally provided in CCR to meet the requirements of 6.6, Part VIII "Instrumentation" of the Chem Rules.

3.3 MEANS OF COMMUNICATION

3.3.1 At least two independent means shall be provided for communicating orders from the navigation bridge to the position in the machinery space or in the control room, from which the speed and direction of thrust of the propellers are normally controlled.

One of these shall be an engine-room telegraph, which provides visual indication of the orders and responses both in the machinery spaces and on the navigation bridge and which is fitted with a sound signal clearly audible in any part of the engine room while the machinery is at work, and distinct in tone from all other signals in the machinery space (refer also to 7.1, Part XI "Electrical Equipment").

Appropriate means of communication shall be provided from the navigation bridge at the engine room to any other position, from which the speed or direction of thrust of the propellers may be controlled.

A single voice-communication device serving two control stations located in close proximity is permissible.

3.3.2 Two-way communication shall be provided between the engine room, auxiliary machinery spaces and boiler room. Onboard the ships equipped with CCR, two-way communication between CCR and navigation bridge, between CCR and the spaces, where cargo and ballast pumps are located, shall be additionally provided.

3.3.3 When installing a voice-communication device, measures shall be taken to ensure clear audibility, with the machinery at work.

3.3.4 Main machinery control rooms of floating docks shall have means of communication in accordance with 19.8, Part XI "Electrical Equipment".

3.3.5 In the case of ships with twin hulls, provision shall be made for voice communication between local control stations of the hulls in addition to communication between local control stations and the common control station in the wheelhouse and the main machinery control room.

4 MACHINERY SPACES, ARRANGEMENT OF MACHINERY AND EQUIPMENT

4.1 GENERAL

4.1.1 Ventilation of machinery spaces shall comply with the requirements of 12.5, Part VIII "Systems and Piping".

4.1.2 Machinery spaces with gas engines shall be fitted with gas concentration sensors and the ultimate concentration level alarm system.

4.1.3 The ventilation of machinery spaces shall be sufficient under normal conditions of ship operation to prevent accumulation of oil product vapour.

4.2 ARRANGEMENT OF MACHINERY AND EQUIPMENT

4.2.1 Engines, boilers, equipment, pipes and valves shall be so arranged as to provide easy access for servicing and repair; the requirements stated in [4.5.3](#) shall also be met.

4.2.2 The arrangement of boilers shall be such that the distance between boilers and fuel tanks is sufficient for a free circulation of air necessary to keep the temperature of the fuel in the tanks below its flash point except as mentioned in 13.3.5, Part VIII "Systems and Piping".

4.2.3 Where auxiliary boilers design installed in the same space with the internal combustion engines will not initiate sparks if flame is accidentally blown out from the furnace, their furnaces shall have metallic screens or other arrangements to protect the equipment of that space if flame is accidentally blown out from the furnace.

4.2.4 The auxiliary oil-fired boilers installed on platforms or on 'tween decks in non-watertight enclosures shall be protected by oil-tight coamings at least 200 mm in height.

4.2.5 Driving machinery of the pumps and fans in the cargo pump rooms of oil tankers, oil tank barges and combination carriers designed for the carriage of oil products with a flash point 60 °C or less and of oil recovery vessels shall be installed in spaces fitted with mechanical ventilation and having no exits leading to the cargo pump rooms.

Driving machinery of the submerged pumps are allowed to be installed in the open deck, provided their design and location comply with the applicable requirements of 20.2.4 Part XI "Electrical Equipment".

Steam engines with working temperatures not exceeding 220 °C and hydraulic motors may be installed in cargo pump rooms.

Drive shafts of pumps and fans shall be carried through bulkheads or decks in gastight sealing glands supplied with effective lubrication from outside the pump room. As far as practicable, the construction of sealing gland shall protect it against being overheated.

Those parts of gland, which may come in contact in case of eventual disalignment of drive shaft, or damage to the bearings, shall be made of such materials, which will not initiate sparks.

If bellows are incorporated in the design, they shall be subjected to test pressure before fitting.

Cargo pumps, ballast pumps and stripping pumps, installed in cargo pump-rooms, as well as in ballast pump-rooms where cargo containing equipment is fitted, and driven by shafts passing through pump-room bulkheads shall be fitted with temperature sensing devices for bulkhead shaft glands, bearings and pump casings.

Alarm shall be initiated in the cargo control room or the pump control station.

4.2.6 Air compressors shall be installed in such places where air is least contaminated by vapours of combustible liquids.

4.2.7 Fuel oil units (refer to [1.2](#)) as well as hydraulic units containing flammable liquids with working pressure above 1,5 MPa and not being a part of main and auxiliary engines, boilers, etc., shall be placed in a separate rooms with self-closing steel doors.

If it is impracticable to locate the main components of such units and systems in a separate space, special consideration shall be given with regard to shielding of the components and location, containment of possible leakages.

4.2.8 Requirements for the arrangement of emergency diesel-generators are outlined in 9.2, Part XI "Electrical Equipment".

4.2.9 In oil recovery ships, the internal combustion engines, boilers and equipment containing sources of ignition as well as relevant air inlets shall be installed in intrinsically safe spaces (refer to 19.2, Part XI "Electrical Equipment").

4.2.10 A blowdown gas caps fitted with gas fuel leakage detectors shall be installed above the dual-fuel internal combustion engines (refer to 9.1, Part IX "Machinery").

4.3 ARRANGEMENT OF FUEL OIL TANKS

4.3.1 In general, fuel oil tanks shall be part of the ship's structure and shall be located outside machinery spaces of category A. Where fuel oil tanks, other than double bottom tanks, are necessarily located adjacent to or within machinery spaces of category A, their surfaces in machinery spaces shall be kept to a minimum and shall preferably have a common boundary with the double bottom tanks. Where such tanks are situated within the boundaries of machinery spaces of category A, they shall not contain fuel oil having flash point less than 60 °C. In general, the use of free standing fuel oil tanks shall be avoided.

Service fuel oil tanks shall comply with the requirements of 13.8.1, Part VIII "Systems and Piping".

4.3.2 Where the use of free standing fuel oil tanks is permitted by the Register, they shall be placed in oil-tight spill trays, and on passenger ships and special purpose ships carrying more than 60 special personnel, outside machinery spaces of category A as well.

4.3.3 Fuel oil tanks located in the machinery space shall not be located immediately above the machinery and equipment with surface temperature under insulation over 220 °C, boilers, internal combustion engines, electrical equipment and, as far as practicable, shall be arranged far apart therefrom.

4.3.4 The arrangement of fuel oil and oil tanks of tankers in way of accommodation, service and refrigerated spaces is permitted, provided they are separated by cofferdams (dimensions and structure of cofferdams – refer to 2.7.5.2, Part II "Hull") or subject to the adoption of other special measures aimed at preventing fuel, oils and their vapours from reaching the specified spaces. When tanks of fuel and oils of other types of ships are located in way of accommodation, service and refrigerated spaces, the cofferdams are recommended for separating them. The manholes of the cofferdams and tanks for fuel and oils, as well as detachable joints of the fuel and oil tanks piping in accommodation and service spaces are not allowed.

4.4 INSTALLATION OF MACHINERY AND EQUIPMENT

4.4.1 The machinery and equipment constituting the propulsion plant shall be installed on strong and rigid seatings and securely attached thereto. The construction of the seatings shall comply with the requirements of 2.11, Part II "Hull".

4.4.2 Boilers shall be installed on bearers in such a way that their welded joints do not rest on the bearer supports.

4.4.3 To prevent shifting of boilers, provision shall be made for efficient stops and securing for rough sea; thermal expansion of boiler structures shall be taken into account.

4.4.4 The main engines, their gears, thrust bearings of shafts shall be secured to seatings with fitted bolts throughout or in part. The bolts may be omitted, if appropriate stops or other means providing reliable protection of equipment from displacement are provided. Where necessary, fitted bolts shall be used to fasten auxiliary machinery to seatings.

4.4.5 The bolts securing the main and auxiliary machinery and shaft bearings to their seatings, end nuts of shafts as well as bolts connecting the lengths of shafting shall be fitted with appropriate lockers against spontaneous loosening.

4.4.6 Where the machinery shall be mounted on shock absorbers, the design of the latter shall be approved by the Register.

Shock absorbing fastenings of the machinery and equipment shall:

maintain vibration-proof insulation properties when the absorbed machinery and equipment are operated in the environmental conditions as per the requirement of [2.3.1](#);

be resistant to the corrosive mediums, temperature and various kinds of radiation;

be equipped with the yielding grounding jumper of sufficient length to prevent radio reception interference and comply with the requirements of safety engineering;

eliminate the interference for operation of other equipment, devices and systems.

4.4.7 In case of installation of machinery, mechanical equipment, ship arrangements and their components on plastic pads or their assembly with the use of polymeric materials, their technology shall be submitted to the Register for approval. Polymeric materials used for the pads and assembly shall be agreed with the Register (refer to Section 6, Part XIII "Materials").

4.4.8 The machinery with horizontal arrangement of the shaft shall be installed parallel to the centre line of the ship. Installing such machinery in any other direction is permitted if the construction of machinery provides for operation under the conditions specified in [2.3](#).

4.4.9 The machinery for driving generators shall be mounted on the same seatings as the generators.

4.5 MEANS OF ESCAPE FROM MACHINERY SPACES

4.5.1 Means of escape from machinery spaces, including ladders, corridors, doors and hatches, shall, if not expressly provided otherwise, provide safe escape to the lifeboat and liferaft embarkation decks.

4.5.2 All the doors as well as the covers of companionways and skylights, which may serve as means of escape from machinery spaces, shall permit of opening and closing both from inside and outside. The covers of companionways and skylights shall be marked, as appropriate, and bear a clear inscription prohibiting to stow any loads on them.

Lifts shall not be considered as forming one of the means of escape.

4.5.3 The main and auxiliary machinery shall be so arranged as to provide passageways from the control stations and servicing flats to the means of escape from the machinery spaces. The width of passageways shall not be less than 600 mm over the whole length. In ships of less than 1000 gross tonnage the width of passageways may be reduced to 500 mm. The width of passageways along the switchboards shall comply with the requirements of 4.6.7, Part XI "Electrical Equipment".

4.5.4 The width of inclining ladders serving as escape routes and the width of doors providing access to embarkation decks shall be at least 600 mm. The width of inclining ladders in ships of less than 1000 gross tonnage may be reduced to 500 mm.

4.5.5 In a passenger ship, each machinery space located below the bulkhead deck shall be provided with at least two means of escape, which shall comply with the requirements of either [4.5.5.1](#) or [4.5.5.2](#), as follows:

.1 the means of escape shall consist of two sets of steel ladders as widely separated as possible, leading to doors (hatches) in the upper part of the space similarly separated and satisfying the requirements of [4.5.1](#). One of these ladders shall be located within a protected enclosure that satisfies the requirements of 2.1.4.5, Part VI "Fire Protection", from the lower part of the space to a safe position outside the space. Self-closing fire doors of the same fire integrity standards shall be fitted in the enclosure. The ladder shall be fixed in such a way that the heat is not transferred into the enclosure through non-insulated fixing points. The protected enclosure shall have minimum internal dimensions of at least 800 x 800 mm, and shall have emergency lighting provisions;

Notes: 1. A "safe position" can be any space, such as steering gear spaces where hydraulic oils for the steering gear equipment are stowed, and special category spaces and ro-ro spaces, from which access is provided and maintained clear of obstacles to the embarkation decks. This excludes lockers and storerooms, cargo spaces and spaces where flammable liquids are stowed.

2. Machinery spaces may include working platforms and passageways, or intermediate decks at more than one deck level. In such case, the lower part of the space shall be regarded as the lowest deck level, platform or passageway within the space. At deck levels, other than the lowest one, where only one means of escape other than the protected enclosure is provided, self-closing fire doors shall be fitted in the protected enclosure at that deck level. Smaller working platforms in-between deck levels, or only for access to equipment or components, need not be provided with two means of escape.

3. A protected enclosure providing escape from machinery spaces to an open deck may be fitted with a hatch as means of egress from the enclosure to the open deck. The hatch shall have minimum internal dimensions of 800 mm x 800 mm.

4. Internal dimensions (refer to Note 3) shall be interpreted as clear width, so that a passage having diameter of 800 mm is available throughout the vertical enclosure, as shown in [Fig. 4.5.5](#), clear of ship's structure, with insulation and equipment, if any. The ladder within the enclosure can be included in the internal dimensions of the enclosure. When protected enclosures include horizontal portions their clear width shall not be less than 600 mm (refer to [Fig. 4.5.5](#)).

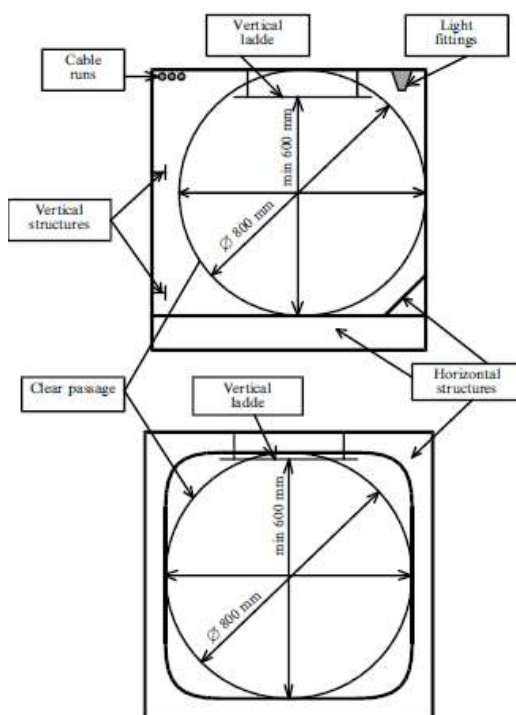

Fig. 4.5.5

.2 the means of escape shall consist of one steel ladder leading to a door (hatch) in the upper part of the space and satisfying the requirements of [4.5.1](#) and additionally, in the lower part of the space and in a position well separated from the ladder referred to, a steel door capable of being operated from each side and which provides access to a safe escape route from the lower part of the space in accordance with [4.5.1](#);

.3 all inclined ladders/stairways with open treads fitted to comply with [4.5.5.1](#) and [4.5.5.2](#) in machinery spaces being part of or providing access to escape routes but not located within a protected enclosure shall be made of steel. Such ladders/stairways shall be fitted with steel shields attached to their undersides, such as to provide escaping personnel protection against heat and flame from beneath.

Note. Inclined ladders/stairways in machinery spaces being part of, or providing access to, escape routes but not located within a protected enclosure shall not have an inclination greater than 60° and shall not be less than 600 mm in clear width. Such requirement need not be applied to ladders/stairways not forming part of an escape route, only provided for access to equipment or components, or similar areas, from one of the main platforms or deck levels within the spaces subject to requirements [4.5.5](#).

4.5.6 Where the machinery spaces in passenger ships are above the bulkhead deck, two means of escape shall be provided, which shall be as widely separated as possible, and the doors (hatches) leading from such means of escape shall be in a position satisfying the requirements of [4.5.1](#). Where such means of escape require the use of ladders, these shall be of steel.

4.5.7 In passenger ships of less than 1000 gross tonnage, the Register may dispense with one of the means of escape from the spaces specified in [4.5.5](#) and [4.5.6](#), due regard being paid to the width and disposition of the upper part of the space. In ships of 1000 gross tonnage and above, the Register may dispense with one means of escape from the above mentioned spaces, including a normally unattended auxiliary machinery space, so long as

the provisions of [4.5.1](#) are satisfied, due regard being paid to the nature of the space and whether persons are normally absent in that space.

4.5.8 The second means of escape shall be provided from the steering gear space when the emergency steering position is located in this space unless there is a direct access to the open deck.

The local steering position located in the steering gear space is considered to be an emergency steering position if a separate emergency steering position is not provided outside steering gear.

4.5.9 On passenger ships two means of escape shall be provided from the main machinery control room (MCRm) and main workshop (MWS) within a machinery space. At least one of these escape routes shall provide a continuous fire shelter to a safe position outside the machinery space.

Notes: 1. A "main workshop (MWS)" means a compartment enclosed on at least three sides by bulkheads or gratings, usually containing welding equipment, metal working machinery and workbenches.

2. A "machinery control room (MCRm)" means a space which serves for control and/or monitoring of machinery used for ship's main propulsion.

3. A "continuous fire shelter" means a route from MWS, or from MCRm, which allows safe escape, without entering the machinery space, to a location outside the machinery space. Such a continuous fire shelter need not be a protected enclosure. The boundaries of the continuous fire shelter shall be at least "A-0" class divisions and be protected by self-closing "A-0" class doors. The continuous fire shelter shall have minimum internal dimensions of at least 800 mm x 800 mm for vertical trunks and 600 mm in width for horizontal trunks, and shall have emergency lighting provisions.

[Fig. 4.5.9.1 — 4.5.9.6](#) represent typical arrangements of the continuous fire shelters through trunks or through spaces/rooms to a location outside the machinery space.

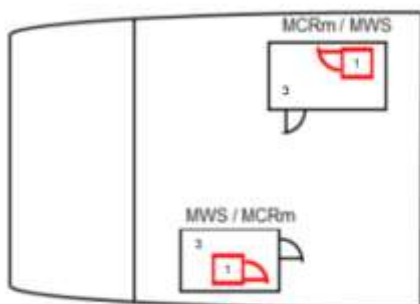

Fig. 4.5.9.1

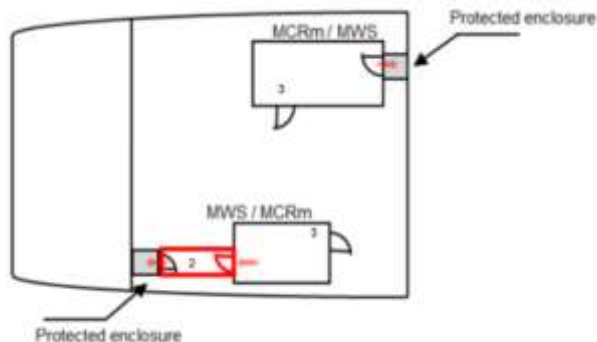

Fig. 4.5.9.2

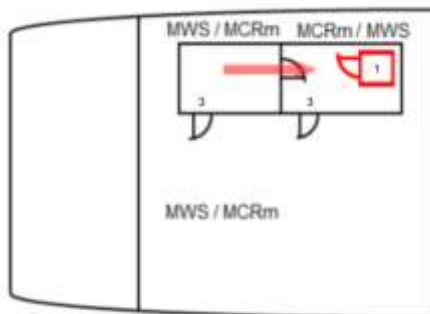

Fig. 4.5.9.3

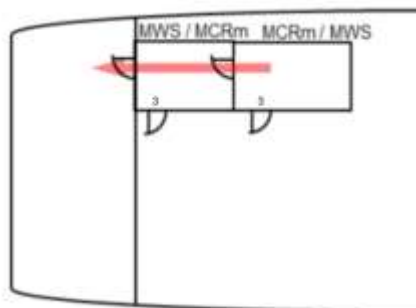

Fig. 4.5.9.4

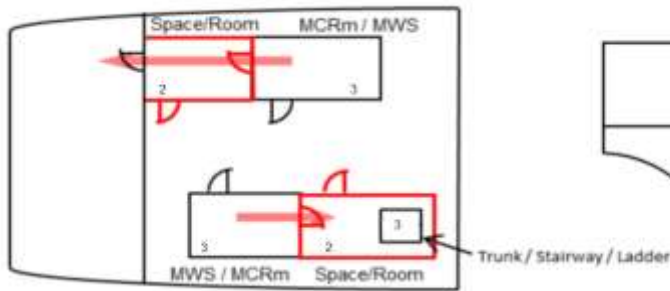

Fig. 4.5.9.5

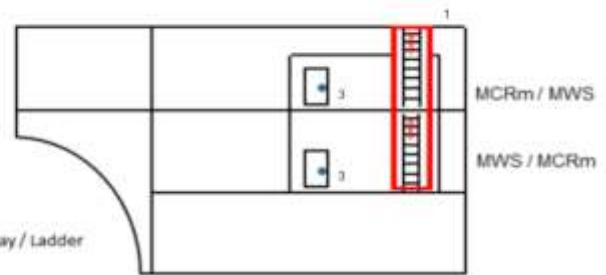

Fig. 4.5.9.6

- 1 Vertical trunk (minimum dimensions: 800 mm x 800 mm) enclosing ladders or stairways to be at least "A-0" class divisions and to be protected by selfclosing "A-0" class doors.
- 2 Horizontal trunk (minimum width: 600 mm) to be at least "A-0" class divisions and to be protected by selfclosing "A-0" class doors.
- 3 Fire integrity not required.

4.5.10 In a cargo ship, at least two means of escape shall be provided from each machinery space of category A, which shall comply with the requirements of either [4.5.10.1](#) or [4.5.10.2](#), as follows:

.1 the means of escape shall consist of two sets of steel ladders as widely separated as possible leading to doors (hatches), from which access is provided to the open deck. One of these means of escape shall be located within a protected enclosure that satisfies the requirements of 2.1.4.5, Part VI "Fire Protection", from the lower part of the space to a safe position outside the space. Self-closing fire doors of the same fire integrity standards shall be fitted in the enclosure. The ladder shall be fixed in such a way that heat is not transferred into the enclosure through non-insulated fixing points. The protected enclosure shall have minimum internal dimensions of at least 800 x 800 mm, and shall have emergency lighting provisions;

Notes: 1. A "safe position" can be any space, excluding cargo spaces, such as steering gear spaces where hydraulic oils for the steering gear equipment are stowed, and vehicle and ro-ro spaces, from which access is provided and maintained clear of obstacles to the open deck. This excludes cargo spaces, lockers and storerooms, cargo pump-rooms and spaces where flammable liquids are stowed.

2. Machinery spaces of category A may include working platforms and passageways, or intermediate decks at more than one deck level. In such case, the lower part of the space shall be regarded as the lowest deck level, platform or passageway within the space. At deck levels, other than the lowest one, where only one means of escape other than the protected enclosure is provided, self-closing fire doors shall be fitted in the protected enclosure at that deck level. Smaller working platforms in-between deck levels, or only for access to equipment or components, need not be provided with two means of escape.

3. A protected enclosure providing escape from machinery spaces to an open deck may be fitted with a hatch as means of egress from the enclosure to the open deck. The hatch shall have minimum internal dimensions of 800 mm x 800 mm.

4. Internal dimensions (refer to Note 3) shall be interpreted as clear width, so that a passage having diameter of 800 mm is available throughout the vertical enclosure, as shown in [Fig. 4.5.5](#), clear of ship's structure, with insulation and equipment, if any. The ladder within the enclosure can be included in the internal dimensions of the enclosure. When protected enclosures include horizontal portions their clear width shall not be less than 600 mm (refer to [Fig. 4.5.5](#)).

.2 the means of escape shall consist of one steel ladder leading to a door (hatch) in the upper part of the space, from which access is provided to the open deck and, additionally,

in the lower part of the space and in a position well separated from the ladder referred to, a steel door capable of being operated from each side and which provides access to a safe escape route from the lower part of the space to the open deck;

.3 all inclined ladders/stairways with open treads fitted to comply with [4.5.10.1](#) and [4.5.10.2](#) in machinery spaces of category A being part of or providing access to means of escape but not located within a protected enclosure shall be made of steel. Such ladders/stairways shall be fitted with steel shields attached to their undersides, such as to provide escaping personnel protection against heat and flame from beneath.

Note. Inclined ladders/stairways in machinery spaces being part of, or providing access to, escape routes but not located within a protected enclosure shall not have an inclination greater than 60° and shall not be less than 600 mm in clear width. Such requirement need not be applied to ladders/stairways not forming part of an escape route, only provided for access to equipment or components, or similar areas, from one of the main platforms or deck levels within the spaces (refer to requirements of [4.5.10](#));

.4 two means of escape shall be provided from the main machinery control room (MCRm) and main workshop (MWS) within a machinery space of category A. At least one of these escape routes shall provide a continuous fire shelter to a safe position outside the machinery space.

Notes: 1. A "main workshop (MWS)" means a compartment enclosed on at least three sides by bulkheads or gratings, usually containing welding equipment, metal working machinery and workbenches.

2. A "machinery control room (MCRm)" means a space which serves for control and/or monitoring of machinery used for ship's main propulsion.

3. A "continuous fire shelter" means a route from MWS, or from MCRm, which allows safe escape, without entering the machinery space, to a location outside the machinery space. Such a continuous fire shelter need not be a protected enclosure. The boundaries of the continuous fire shelter shall be at least "A-0" class divisions and be protected by self-closing "A-0" class doors. The continuous fire shelter shall have minimum internal dimensions of at least 800 mm x 800 mm for vertical trunks and 600 mm in width for horizontal trunks, and shall have emergency lighting provisions. [Fig. 4.5.9.1 — 4.5.9.6](#) represent typical arrangements of the continuous fire shelters through trunks or through spaces/rooms to a location outside the machinery space.

4.5.11 In fishing vessels of more than 1000 gross tonnage one means of escape from machinery spaces of category A may be provided on the condition that it leads directly onto the open deck, the spaces are entered only periodically and the maximum travel distance to the door (hatch) leading directly onto open deck from the control stations of the equipment located in the space is 5 m or less. In cargo ships of less than 1000 gross tonnage, the Register may dispense with one of the means of escape from machinery spaces of category A, due regard being paid to the dimension and disposition of the upper part of the space. In addition, the means of escape in these ships need not comply with the requirements for an enclosure listed in paragraph [4.5.10.1](#).

4.5.12 From each machinery space other than that of category A, at least two escape routes shall be provided except for spaces that are entered only occasionally, and for spaces where the maximum travel distance to the door (hatch) is 5 m or less.

Note. The travel distance shall be measured from any point normally accessible to the crew taking into account machinery and equipment within the space.

4.5.13 In addition to the requirements of [4.5.12](#), the steering gear space of a cargo ship shall comply with the following requirements:

.1 steering gear spaces which do not contain the emergency steering position need only have one means of escape. The local steering position is considered to be an emergency steering position if a separate emergency steering position is not provided;

.2 steering gear spaces containing the emergency steering position can have one means of escape provided it leads directly onto the open deck. Otherwise, two means of escape shall be provided but they do not need to lead directly onto the open deck.

4.5.14 The escape routes from shaft tunnels and pipe ducts shall be equipped by watertight closing means or enclosed in watertight trunks carried to above the bulkhead deck or the uppermost waterline.

Doors from shaft tunnels and pipe ducts leading in the machinery spaces and cargo pump rooms shall comply with the requirements of 7.12, Part III "Equipment, Arrangements and Outfit".

4.5.15 In oil tankers, oil tank barges and combination carriers, one of the escape routes from pipe ducts situated below the cargo tanks may lead in the cargo pump room. Exit in the machinery space is not permitted.

4.5.16 The doors and hatch covers of cargo pump rooms in oil tankers and oil tank barges shall be capable of being opened and closed both from inside and from outside; their design shall preclude the possibility of sparking.

4.5.17 Escape routes from cargo pump rooms shall lead directly to the open deck. Exit to other machinery spaces is not permitted.

4.5.18 If two adjacent machinery spaces communicate through a door and each of them has only one means of escape through the casing, these means of escape shall be located at the opposite sides.

4.6 INSULATION OF HEATED SURFACES

4.6.1 Surfaces of machinery, equipment and piping with temperatures above 220 °C, which may be impinged as a result of a fuel system failure, shall be properly insulated.

4.6.2 The insulating materials and surface of insulation shall be in accordance with the requirements of 2.1.1.5, Part VI "Fire Protection".

4.6.3 Structural measures shall be taken to prevent any oil that may escape under pressure from any pump, filter or heater from coming into contact with heated surfaces.

5 SHAFTING

5.1 GENERAL

5.1.1 Shafting is a solid unit connecting the engine with the propeller. Optimum location of the shafting within the ship space shall be provided to ensure rational combination of loads of the shafting components, its supports and the engine. For this a number of design, scientific, technical and engineering measures shall be taken which are unified by a concept "Shafting alignment" and approved by the Register.

5.1.2 The minimum shaft diameters without allowance for subsequent turning on lathe during service life shall be determined by formulae given in this Section. It is assumed that additional stresses from torsional vibration will not exceed permissible values stipulated in [Section 8](#).

Tensile strength of the shaft material shall be not less than 400 MPa and for shafts which may experience vibratory stresses close to the permissible stresses for transient operation – not less than 500 MPa.

Alternative calculation methods are permitted. These methods shall take into account criteria of static and fatigue strength and include all the relevant loads under all permissible operating conditions.

The shaft diameters determined for ships of restricted navigation areas **R2** and **R3** according to [5.2.1](#), [5.2.2](#) and [5.2.3](#) may be reduced by 5 %.

5.1.3 In icebreakers and ice class ships, the propeller shafts shall be protected from ice effects.

5.1.4 In ships with no obstruction for the propeller shaft to slip out of the sterntube, means shall be provided which, in the event of the propeller shaft breaking, will prevent its slipping out of the sterntube; alternative arrangements shall be made to preclude flooding of the engine room, should the propeller shaft be lost.

5.1.5 The areas between the sterntube, strut bearing (if any) and propeller boss shall be protected by a strong casing.

5.2 CONSTRUCTION AND DIAMETERS OF SHAFTS

5.2.1 The design diameter of the intermediate shaft d_{int} , in mm, shall not be less than

$$d_{int} = F \sqrt[3]{P/n}, \quad (5.2.1)$$

where F = factor taken depending on the type of machinery installation as follows:

95 for installations with main machinery of rotary type or main internal combustion engines fitted with hydraulic or electromagnetic couplings;

100 for other machinery installations with internal combustion engines;

P = rated power of intermediate shaft, kW;

n = rated speed of intermediate shaft, rpm.

5.2.2 The diameter of thrust shaft in external bearing on a length equal to thrust shaft diameter on either side of the thrust collar and, where roller thrust bearings are used, on a length inside the housing of thrust bearing, shall not be less than 1,1 times the intermediate shaft diameter determined by Formulas (5.2.1), (5.2.4). Beyond the said lengths the diameter of the thrust shaft may be tapered to that of the intermediate shaft.

5.2.3 The design diameter of the propeller shaft, in mm, shall not be less than that determined by the following formula:

$$d_p = 100k \sqrt[3]{P/n}, \quad (5.2.3)$$

where k = factor assumed as follows proceeding from the shaft design features:

for the portion of propeller shaft between the propeller shaft cone base or the aft face of the propeller shaft flange and the forward edge of the aftermost shaft bearing, subject to a minimum of $2,5 d_p$):

$k = 1,22$, where the propeller is keyless fitted onto the propeller shaft taper or is attached to an integral propeller shaft flange;

$k = 1,26$, where the propeller is keyed onto the propeller shaft taper;
for the portion of propeller shaft between the forward edge of the aftermost shaft bearing, or aft strut bush, and the forward edge of the forward sterntube seal $k=1,15$, for all types of design.

Other terms are as defined in 5.2.1.

On the portion of propeller shaft forward of the forward edge of the forward sterntube seal the diameter of the propeller shaft may be tapered to the actual diameter of the intermediate shaft.

Where surface hardening is used, the diameters of propeller shafts may be reduced on agreement with the Register.

5.2.4 The diameter of the shaft made of steel with tensile strength of more than 400 MPa may be determined by the following formula:

$$d_{red} = d \sqrt[3]{560/(R_{msh} + 160)}, \quad (5.2.4)$$

where d_{red} = reduced diameter of the shaft, mm;

d = design diameter of the shaft, mm;

R_{msh} = tensile strength of the shaft material.

In all cases the tensile strength in the formula shall be assumed not exceeding 760 MPa (for carbon and carbon-manganese steel)/800 MPa (for alloyed steel) for intermediate and thrust shafts and 600 MPa for propeller shaft.

However, where materials exhibit similar fatigue life as conventional steels, special approval of alloy steel used for intermediate shaft material (refer to [Appendix 2](#)) shall be permitted.

5.2.5 The diameters of shafts in icebreakers and ice class ships shall exceed the design diameters by value indicated in [Table 5.2.5](#).

Table 5.2.5

| Shafts | Ice class ships | | | | | | | Icebreakers | |
|-------------------------|-----------------|------|------|------|------|------|-------------|--------------|------------|
| | Ice1, Ice2 | Ice3 | Arc4 | Arc5 | Arc6 | Arc7 | Arc8 – Arc9 | Centre shaft | Side shaft |
| Intermediate and thrust | 0 | 4 | 8 | 12 | 13,5 | 15 | 1 | 18 | 20 |
| Propeller | 5 | 8 | 15 | 20 | 25 | 30 | 1 | 45 | 50 |

¹ It shall be agreed with the Register in each particular case.

The diameter d of propeller shafts, in mm, for icebreakers and ice class ships (except for ships of ice class **Ice1**) shall, besides, meet the following condition in way of aft bearings:

$$d \geq a^3 \sqrt{bs^2 R_{mbl} / R_e}, \quad (5.2.5)$$

where a = factor equal to:
 10,8, with propeller boss diameter equal to, or less than $0,25D$ (D is the propeller diameter);
 11,5, with propeller boss diameter greater than $0,25D$;
 b = actual width of expanded cylindrical section of the blade on the radius of $0,25R$ for unit-cast propellers and of $0,35R$ for CPP, m;
 s = maximum thickness of expanded cylindrical section of the blade on the radii given for b , mm;
 R_{mbl} = tensile strength of the blade material, MPa;
 R_e = yield stress of propeller shaft material, MPa.

5.2.6 If the shaft has a central hole, its bore shall not exceed 0,4 of the design diameter of the shaft.

If considered necessary, the diameter of central hole may be increased to the value obtained from the formula

$$d_c \leq (d_a^4 - 0,97d^3 d_a)^{1/4}, \quad (5.2.6)$$

where d_c = diameter of central hole;
 d_a = actual shaft diameter;
 d = design diameter of the shaft without regard for central hole.

5.2.7 Where the shaft has a radial hole, the shaft diameter shall be increased over a length of at least seven diameters of the hole. The hole shall be located at mid-length of the bossed portion of the shaft, and its diameter shall not exceed 0,3 of the shaft design diameter. In all cases, irrespective of the hole diameter, the diameter of the shaft shall be increased by not less than 0,1 times the design diameter. The edges of the hole shall be rounded to a radius not less than 0,35 times its diameter and the inside surface shall have a smooth finish.

Note. This para does not consider a radial hole, intersection between a radial hole and an eccentric axial bore.

5.2.8 The diameter of a shaft having a longitudinal slot shall be increased by at least 0,2 of the design diameter of that shaft. The diameter ratio (refer to [5.2.6](#)) shall not

exceed 0,7, the slot length shall not exceed 0,8 and slot width shall not exceed 0,15 of the design shaft diameter. Up to three slots are permitted, with consideration for their equally-spaced location.

The bossed portion of the shaft shall be of such length as to extend beyond the slot for not less than 0,25 of the design diameter of the shaft. The transition from one diameter to another shall be smooth. The ends of the slot shall be rounded to a radius of half the width of the slot and the edges – to a radius of at least 0,35 times the width; the surface of the slot shall have a smooth finish.

5.2.9 The diameter of a shaft having a keyway shall be increased by at least 0,1 of its design diameter. After a length of not less than 0,2 of the design diameter from the ends of the keyway, no increase of the shaft diameter is required.

If the keyway is made on the outboard end of the propeller shaft, the diameter need not be increased.

Keyways are not recommended in the shafts with a barred speed range.

5.2.10 For intermediate shafts, thrust shafts and inboard end of propeller shafts the coupling flange shall have a minimum thickness of 0,2 times the required diameter of the intermediate shaft, or the thickness of the coupling bolt diameter (refer to Formula (5.3.2)) calculated for the material having the same tensile strength as the corresponding shaft, whichever is the greater.

The thickness of coupling flange of the outboard end of propeller shaft under the bolt heads shall not be less than 0,25 times the required diameter of the shaft at the flange.

5.2.11 The fillet radius at the base of aft flange of the propeller shaft shall not be less than 0,125 and for other flanges of shafts – shall not be less than 0,08 of the required diameter at the flange. The fillet may be formed by multiradii in such a way that the stress concentration factor will not be greater than that for a constant fillet radius.

The fillets shall have a smooth finish and shall not be recessed in way of nuts and bolt heads.

5.2.12 Fillet radii in the transverse section of the bottom of the keyway shall not be less than 0,0125 of the diameter of the shaft, but at least 1 mm.

5.2.13 Where keys are used to fit the propeller on the propeller shaft cone, the latter shall have a taper not in excess of 1:12, in case of keyless fitting – according to 5.4.1.

5.2.14 On the cone base side, the keyways in shaft cones shall be ski-shaped, while in propeller shaft cones they shall be spoon-shaped in addition.

Where the outboard end of a propeller shaft having the diameter in excess of 100 mm is concerned, the distance between the cone base and the spoon-shaped keyway end shall be at least 0,2 of the shaft diameter required, with the ratio of the keyway depth to the shaft diameter less than 0,1 and 0,5 at least of the shaft diameter required, with the ratio of the keyway depth to the shaft diameter exceeding 0,1.

In coupling shaft cones, the ski-shaped keyway end shall not extend beyond the cone base.

Where the key is secured by screws in the keyway, the first screw shall be positioned at least 1/3 of the shaft cone length from the shaft cone base. The bore length shall not exceed the propeller diameter. The bore edges shall be rounded off. Where the shaft has blind axial bores, the bore edges and end shall also be rounded off. The fillet radius shall not be less than specified in 5.2.12.

5.2.15 Propeller shafts shall be effectively protected against exposure to sea water.

5.2.16 Propeller shaft liners shall be made of such alloys, which possess sufficient corrosion resistance in sea water.

5.2.17 The thickness s of a bronze liner, in mm, shall not be less than

$$s = 0,03d_p' + 7,5 \quad (5.2.17)$$

where d_p' – diameter of the propeller shaft under the liner, mm.

The thickness of the liner between the bearings may be reduced to $0,75s$.

5.2.18 Continuous liners are recommended to be used.

Liners consisting of two or more lengths shall be joined by welding or by other methods approved by the Register. The butt welded joints of the liner shall be arranged outside the region of bearings. In case of non-continuous liners the portion of the shaft between the liners shall be protected against the action of sea water by a method approved by the Register.

5.2.19 To prevent water from reaching the propeller shaft cone, appropriate sealing shall be provided.

Structural provision shall be made for hydraulic testing of the sealing.

5.2.20 The liners shall be shrunk on the shaft in such a way as to provide tight interference between mating surfaces. The use of pins or other parts for securing of liners to the shaft is not permitted.

5.3 SHAFT COUPLINGS

5.3.1 The bolts used at the coupling flanges of shafts shall be all fitted bolts of cylindrical section.

If using coupling flanges without fitted bolts the technical substantiation shall be submitted to the Register for review.

5.3.2 The coupling bolt diameter, in mm, shall not be less than

$$d_b = 0,65 \sqrt{\frac{d_{int}^3 (R_{msh} + 160)}{iDR_{mb}}}, \quad (5.3.2)$$

where d_{int} = diameter of intermediate shaft determined by Formula (5.2.1) taking into account the ice classes requirements under 5.2.5, mm.

If the shaft diameter is increased to account for torsional vibration d_{int} will be taken as the increased diameter of intermediate shaft;

R_{msh} = tensile strength of the shaft material, MPa;

R_{mb} = tensile strength of the fitted coupling bolt material, MPa, taken: $R_{msh} \leq R_{mb} \leq 1,7R_{msh}$, but not higher than 1000 MPa;

i = number of fitted coupling bolts;

D = pitch circle diameter of coupling bolts, mm.

The diameter of bolts, by which the propeller is secured to the propeller shaft flange shall be agreed with the Register in each particular case.

5.4 KEYLESS FITTING OF PROPELLERS AND SHAFT COUPLINGS

5.4.1 In case of keyless fitted propellers and shaft couplings, the taper of the shaft cone shall not exceed 1:15. Provided the taper does not exceed 1:50, the shafts may be assembled with the couplings without the use of an end nut or other means of securing the coupling.

The stoppers of the end nuts shall be secured to the shaft.

5.4.2 A keyless assembly shall generally be constructed without a sleeve between the propeller boss and the shaft.

If using constructions with intermediate sleeves the technical substantiation shall be submitted to the Register for review.

5.4.3 When fitting the keyless shrunk assembly, the axial pull-up of the boss in relation to the shaft or intermediate sleeve, as soon as the contact area between mating surfaces is checked after eliminating the clearance, shall be determined by the following formula:

$$\Delta h = \left[\frac{80B}{hz} \sqrt{\left(\frac{1910PL^3}{nD_w} \right)^2 + T^2} + \frac{D_w(\alpha_y - \alpha_w)(t_e - t_m)}{Z} \right] k, \quad (5.4.3)$$

where Δh = axial pull-up of the boss in the course of fitting, cm;
 B = material and shape factor of the assembly, MPa^{-1} , determined by the formula

$$B = \frac{1}{E_y} \left(\frac{y^2 + 1}{y^2 - 1} + \nu_y \right) + \frac{1}{E_w} \left(\frac{1 + w^2}{1 - w^2} - \nu_w \right)$$

For assemblies with a steel shaft having no axial bore, the factor B may be obtained from [Table 5.4.3-1](#) using linear interpolation;

E_y, E_w = modulus of elasticity of the boss material, MPa; modulus of elasticity of shaft material, MPa;

ν_y = Poisson's ratio for the boss material;

ν_w = Poisson's ratio for the shaft material; for steel $\nu_w=0,3$;

y = mean factor of outside boss diameter;

w = mean factor of shaft bore;

D_w = mean outside shaft diameter in way of contact with the boss or intermediate sleeve (refer to [Fig. 5.4.3](#)):

Table 5.4.3-1

Factor $B \times 10^5, \text{MPa}^{-1}$, Steel shaft $w=0, E_w=2,059 \times 10^5, \text{MPa}, \nu_w=0,3$

| Factor y | Copper alloy boss $\nu_y=0,34$ with E_y, MPa | | | | | | | Steel boss $\nu_y=0,3$ with $E_y=2,059 \times 10^5, \text{MPa}$ |
|------------|---|---------------------|---------------------|---------------------|---------------------|---------------------|---------------------|---|
| | $0,98 \times 10^5$ | $1,078 \times 10^5$ | $1,176 \times 10^5$ | $1,274 \times 10^5$ | $1,373 \times 10^5$ | $1,471 \times 10^5$ | $1,569 \times 10^5$ | |
| 1,2 | 6,34 | 5,79 | 5,34 | 4,96 | 4,63 | 4,34 | 4,09 | 3,18 |
| 1,3 | 4,66 | 4,26 | 3,95 | 3,66 | 3,43 | 3,22 | 3,04 | 2,38 |
| 1,4 | 3,83 | 3,52 | 3,25 | 3,03 | 2,83 | 2,67 | 2,52 | 1,98 |
| 1,5 | 3,33 | 3,07 | 2,83 | 2,64 | 2,48 | 2,34 | 2,21 | 1,74 |
| 1,6 | 3,01 | 2,77 | 2,57 | 2,40 | 2,24 | 2,12 | 2,01 | 1,59 |
| 1,7 | 2,78 | 2,48 | 2,38 | 2,22 | 2,09 | 1,97 | 1,87 | 1,49 |
| 1,8 | 2,62 | 2,38 | 2,23 | 2,09 | 1,97 | 1,86 | 1,76 | 1,41 |
| 1,9 | 2,49 | 2,29 | 2,13 | 1,99 | 1,88 | 1,77 | 1,68 | 1,35 |
| 2,0 | 2,39 | 2,20 | 2,05 | 1,92 | 1,80 | 1,70 | 1,62 | 1,29 |
| 2,1 | 2,30 | 2,13 | 1,98 | 1,86 | 1,74 | 1,65 | 1,57 | 1,25 |

| Factor y | Copper alloy boss $\nu_y=0,34$ with E_y , MPa | | | | | | | Steel boss $\nu_y=0,3$ with $E_y=2,059$ $\times 10^5$, MPa |
|---------------|---|---------------------|---------------------|---------------------|---------------------|---------------------|---------------------|--|
| | $0,98 \times 10^5$ | $1,078 \times 10^5$ | $1,176 \times 10^5$ | $1,274 \times 10^5$ | $1,373 \times 10^5$ | $1,471 \times 10^5$ | $1,569 \times 10^5$ | |
| 2,2 | 2,23 | 2,06 | 1,92 | 1,79 | 1,69 | 1,60 | 1,53 | 1,22 |
| 2,3 | 2,18 | 2,01 | 1,88 | 1,75 | 1,65 | 1,57 | 1,49 | 1,19 |
| 2,4 | 2,13 | 1,97 | 1,84 | 1,72 | 1,62 | 1,54 | 1,46 | 1,17 |

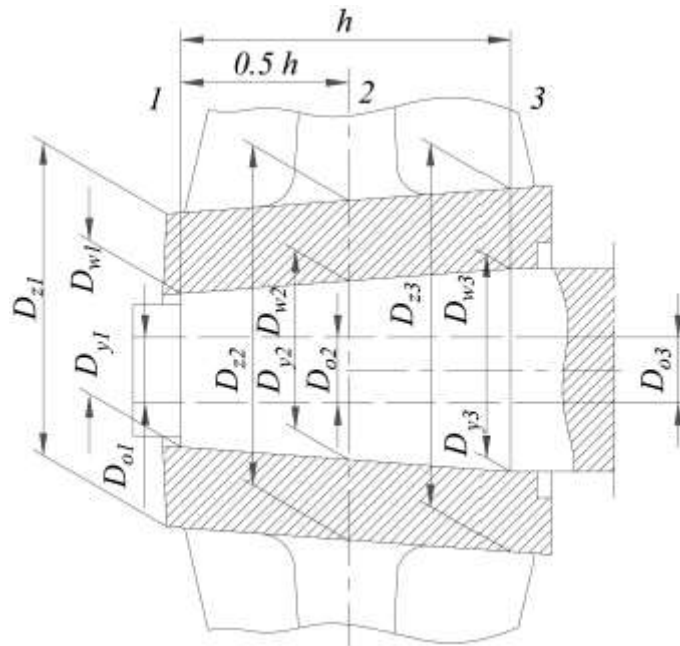

Fig. 5.4.3

Without intermediate sleeve:

$$D_{w1} = D_{y1}; \quad D_{w2} = D_{y2}; \quad D_{w3} = D_{y3};$$

$$D_w = D_y.$$

with intermediate sleeve:

$$D_{w1} \neq D_{y1}; \quad D_{w2} \neq D_{y2}; \quad D_{w3} \neq D_{y3};$$

$$D_w \neq D_y.$$

$$y = \frac{D_{z1} + D_{z2} + D_{z3}}{D_{y1} + D_{y2} + D_{y3}} \text{ – for the boss;}$$

$$w = \frac{D_{o1} + D_{o2} + D_{o3}}{D_{w1} + D_{w2} + D_{w3}} \text{ – for the shaft;}$$

$$D_w = (D_{w1} + D_{w2} + D_{w3})/3;$$

$$D_y = (D_{y1} + D_{y2} + D_{y3})/3;$$

D_y = mean internal boss diameter in way of contact with the shaft or intermediate sleeve, cm;
 h = active length of the shaft cone or sleeve at the contact with the boss, cm;
 z = taper of the boss;
 P = power transmitted by the assembly, kW;
 n = speed, rpm.
 L = factor for ice class ships according to [Table 5.4.3-2](#);
 T = propeller thrust at ahead speed, in kN (where data are unavailable, refer to 2.2.2.6, Part III "Equipment, Arrangements and Outfit");
 α_y, α_w = thermal coefficient of linear expansion of the boss material, 1/°C; thermal coefficient of linear expansion of the shaft material, 1/°C;
 t_e, t_m = temperature of the assembly in service conditions, °C; temperature of the assembly in the course of fitting °C;
 $k=1$ = for assemblies without intermediate sleeve;
 $k=1,1$ = for assemblies with the use of intermediate sleeve.

Table 5.4.3-2

| Assembly | Ice class ships | | | | | | | Icebreakers | |
|----------------------|-----------------|------|------|------|-------|------|--------------|--------------|------------|
| | Ice1, Ice2 | Ice3 | Arc4 | Arc5 | Arc6 | Arc7 | Arc8, Arc9 | Centre shaft | Side shaft |
| Propeller with shaft | 1,05 | 1,08 | 1,15 | 1,20 | 1,25 | 1,30 | ¹ | 1,45 | 1,50 |
| Coupling with shaft | 1,0 | 1,04 | 1,08 | 1,12 | 1,135 | 1,15 | ¹ | 1,18 | 1,20 |

¹ It shall be agreed with the Register in each particular case.

For ice class ships, the value Δh shall be chosen as the greater of the results obtained from calculations for extreme service temperatures, i.e.:

$t_e=35$ °C for $L=1$;

$t_e=0$ °C for $L>1$.

In the absence of ice classes the calculation shall be made solely for the maximum service temperature $t_e=35$ °C for $L=1$.

5.4.4 When assembling steel couplings and shafts with cylindrical mating surfaces, the interference fit shall be determined by the following formula:

$$\Delta D = \frac{80B}{h} \sqrt{\left(\frac{1910PL^3}{nD_w}\right)^2 + T^2}, \quad (5.4.4)$$

where ΔD = interference fit for D_w , cm.

Other terms are as defined in [5.4.3](#).

5.4.5 For propeller bosses and half-couplings in keyless assemblies with the shafts, the following condition shall be met:

$$\frac{A}{B} \left[\frac{C}{D_y} + (\alpha_y - \alpha_w)t_m \right] \leq 0,75R_e, \quad (5.4.5)$$

where A = shape factor of the boss determined by the formula

$$A = \frac{1}{y^2-1} \sqrt{1+3y^4}.$$

The factor A may be obtained from [Table 5.4.5](#) by linear interpolation.

$C = \Delta h_r z$ = for assemblies with conical mating surfaces;

$C = \Delta D_r$ = for assemblies with cylindrical mating surfaces;

Δh_r = actual pull-up of the boss in the course of fitting at a temperature t_m , cm; $\Delta h_r \geq \Delta h$;

ΔD_r = actual interference fit of the assembly with cylindrical mating surfaces, in cm; $\Delta D_r \geq \Delta D$;
 R_e = yield stress of the boss material, MPa.

Other terms are as defined in [5.4.3](#).

Table 5.4.5

Factor A

| y | A | y | A |
|-----|------|-----|------|
| 1,2 | 6,11 | 1,9 | 2,42 |
| 1,3 | 4,48 | 2,0 | 2,33 |
| 1,4 | 3,69 | 2,1 | 2,26 |
| 1,5 | 3,22 | 2,2 | 2,20 |
| 1,6 | 2,92 | 2,3 | 2,15 |
| 1,7 | 2,70 | 2,4 | 2,11 |
| 1,8 | 2,54 | | |

5.5 ARRANGEMENT OF SHAFTING SUPPORTS

5.5.1 The number of the shaftline supports, their position along the axis and in the vertical plane as well as the loads carried shall be determined on the basis of calculation made by a proven procedure agreed with the Register.

5.5.2 The distance between the reaction forces of the adjacent shaftline bearings with no concentrated masses in span shall meet the following condition:

$$5,5a\sqrt{d} \leq l \leq a\lambda\sqrt{d}, \quad (5.5.2)$$

where l = span length (distance between the reactions of adjacent supports), m;

d = minimum outside shaft diameter in span, m;

n = shaft speed, in rpm;

λ = factor taken equal to:

14 when $n \leq 500$ rpm or $300/\sqrt{n}$ when $n > 500$ rpm;

a = factor for bored shafts taken equal to $\sqrt[4]{1+b^2}$,

$b = d_o/d$ = ratio of the bore diameter d_o the outside shaft diameter d .

Note. Restriction on the minimum length (the left part of equation (5.5.2)) used for all spans except for that nearest to the propeller.

5.5.3 It is recommended to seek the minimum number of shaftline supports and the maximum possible length of the spans between them.

5.5.4 The lengths of the spans between the shaft supports shall be checked by the bending vibration calculation.

5.5.5 The shaftline supports shall be so installed that the engine or reduction gear components (bearings, gear wheels) take up loads within the permissible limits.

5.5.6 The reactions of all shaftline supports shall be positive.

5.6 SHAFT BEARINGS

5.6.1 The propeller shaft bearing nearest to the propeller, whether the bearing is in stern tube or in a strut, shall meet the requirements of [Table 5.6.1](#). Other propeller shaft bearings shall meet the condition in formula (5.6.1).

$$l \geq R/qd, \quad (5.6.1)$$

where the symbols and values for q are taken from [Table 5.6.1](#).

Table 5.6.1

| Bearing material | l/d^1 , not less than | q^2 , in MPa, not more than |
|--|-------------------------|-------------------------------|
| Oily-lubricated white metal (babbitt) | 2 ³ | 1,0 ³ |
| Rubber or other water-lubricated materials approved by the Register | 4 ⁴ | 0,25 |
| Rubber or other synthetic oil- or environment-friendly oily liquid-lubricated materials approved by the Register | 2 ⁵ | 1,0 ⁵ |

¹ l = length of bearing; d = design shaft journal diameter in way of bearing.
² q = contact pressure taken up by the bearing, $q = R/(l \times d)$, where R – reaction of support.
³ The length of the bearing may be reduced if the contact pressure does not exceed 0,8 MPa as determined by static bearing reaction calculation taking into account shaft and propeller weight which is deemed to be exerted solely on the aft bearing divided by the projected area of the shaft. In all cases, the length of the bearing shall not be less than 1,5 of the actual shaft diameter in way of the bearing.
⁴ The length of the bearing of synthetic material may be reduced, however, it shall not be less than 2,0 times of the actual shaft diameter in way of the bearing, provided the results of the operational check (of the bearing design and material) are satisfactory. Synthetic materials used for water lubricated bearings shall be Type Approved. The type approval requirements shall be applied to all nearest to the propeller shaft bearings made of synthetic materials. (The type approval testing requirement shall comply with the requirements of 6.13, Part XIII "Materials").
⁵ The length of the bearing may be less provided the nominal bearing pressure is not more than 0,6 MPa as determined by static bearing reaction calculation taking into account shaft and propeller weight which is deemed to be exerted solely on the bearing divided by the projected area of the shaft. However, the minimum length shall be not less than 1,5 times the actual shaft diameter in way of the bearing.
The nominal bearing pressure may be increased in case the material has proven satisfactory testing and operating experience as well as technical justification is provided. Synthetic materials used for oil lubricated bearings shall be Type Approved. The type approval requirements shall be applied to all nearest to the propeller shaft bearings made of synthetic materials. (The type approval testing requirement shall comply with the requirements of 6.13, Part XIII "Materials").

Note. The length of a grease lubricated bearing shall be not less than 4,0 times the actual shaft diameter in way of the bearing.

5.6.2 The water cooling of sterntube bearings shall be of forced type (refer to 15.1, Part VIII "Systems and Piping").

The water supply system shall be provided with a flow indicator and with alarms for the minimum flow of water.

Where an open system of seawater lubrication is applied for the sternbush bearings of ships operating in shallow waters, and of specialized vessels, such as wet dredgers, suction dredgers, it is recommended that an efficient seawater cleaning device (filter, cyclone filter, etc.) shall be incorporated in the circulation system of the sternbush bearing, or sternbush bearings with mud collectors to be washed subsequently shall be fitted.

The non-return shut-off valve controlling the supply of water to sterntube bearings shall be fitted on the sterntube or the after peak bulkhead.

5.6.3 The oil-lubricated sternbush bearings shall be provided with forced cooling arrangements unless the after peak tank is permanently filled with water.

Indication of temperature of oil or bearing bush shall be provided.

5.6.4 If a gravity system of lubrication is used for sternbush bearings, the lubricating oil tanks shall be fitted with oil level indicators and low level alarms.

5.6.5 When using synthetic materials, the bearing clearance shall consider the material swelling and thermal expansion properties. This clearance shall not be less than 1,5 mm in the diameter of the bearing, unless a lower clearance (below 1,5 mm) is specified, as confirmed by the manufacturer's recommendations, and there is documented evidence of a satisfactory service history with a reduced clearance.

5.7 STERTUBE SEALING ARRANGEMENTS

5.7.1 Sterntube arrangements shall be fitted with sterntube sealing arrangements providing the efficient protection against emergency intrusion of sea water inside the hull, and the environmental safety of sterntube arrangement.

5.7.2 The minimum and the maximum permissible volumes of the refrigerant leakage into the ambient space and inside the hull shall be technically substantiated.

5.8 BRAKING DEVICES

5.8.1 The shaftline shall comprise appropriate braking devices. Such devices may be a brake, a stopping or a shaft turning gear preventing rotation of the shaft in the event the main engine goes out of action.

5.8.2 The braking device shall ensure the retention of the failed shafting during the towing of the ship.

5.8.3 In ships with multi-shaft propulsion plants, the braking device shall ensure the retention of a failed shafting during movement and maneuvering of the ship while the rest of the shafting is in operation.

5.9 HYDRAULIC TESTS

5.9.1 Propeller shaft liners and cast sterntubes shall be hydraulically tested to a pressure of 0,2 MPa upon completion of machining. Hydraulic tests of welded and forged-and-welded sterntubes may be omitted, providing non-destructive testing of 100 per cent of welds.

5.9.2 After assembling, the seals of the sterntube when the closed lubrication system is used shall be tested for tightness by a pressure head up to the working level of liquid in gravity tanks. In general, the test shall be carried out while the propeller shaft is turning.

5.10 SHAFTS WITH FIBER-REINFORCED COMPOSITE PLASTIC COMPONENTS

5.10.1 Requirements for polymer composite materials for manufacturing of the shafting parts are given in 6.12 of Part XIII "Materials".

5.10.2 In addition to the documentation specified in Section 3 of Part I "Classification" the following shall be submitted

specification for the materials used, including a list of initial components, technological and auxiliary materials, the composition of the fiber-polymer plastic and its physical and mechanical properties;

a guideline document on manufacturing technology indicating the composition of the reinforcement material and the binder, the structure of the reinforcement by layers, the packing density (surface density), the number of layers of the reinforcement material, as well as the requirements for manufacturing quality control, including the norms of permissible defects, as well as technological instructions for eliminating unacceptable defects;

drawings of joining parts of fiber-polymer plastic with metal elements as well as strength calculations considering [5.10.3](#).

5.10.3 Strength calculations shall take into account shaft loads, considering Chapter [5.2](#), and check the conditions of strength, stiffness and stability of the links. The norms of hazardous and permissible stresses and strains shall be determined, it has been demonstrated that the strength of the joints of parts made of polymer composite material with metal elements is not lower than the strength of the parts to be joined. The accuracy of the calculations, the design scheme and the applied methodology shall be agreed with the Register.

5.10.4 Manufacturer's documents of parts of shaftings shall specify:
permissible and unacceptable defects, their types and evaluation criteria, including the internal defects determined by non-destructive testing methods;

the frequency of visual inspections of the amount of damage by non-destructive testing for the accumulation of internal damage over the period of operation shall be performed at least every 5 years.

5.10.5 Shafts shall remain operative under environmental conditions in accordance with the requirement of [2.3.1](#), be resistant to vibration loads, taking into account [Section 9](#), be moisture and oil resistant.

6 PROPELLERS

6.1 GENERAL

6.1.1 The requirements of this Section apply to metal fixed-pitch propellers (FPP), both solid and detachable-blade propellers, as well as to controllable-pitch propellers (CPP).

6.1.2 The design and size of propellers of the main active means of ship's steering shall meet the requirements of the present Section.

The scope of requirements for the design and size of propellers of the auxiliary AMSS may be reduced, subject to agreement with the Register.

6.2 BLADE THICKNESS

6.2.1. Propeller blade thickness is checked in the design root section and in the blade section at the radius $r = 0,6R$ where R is propeller radius. The location of the design root section is adopted as follows:

for solid propellers – at the radius $0,2R$ where the propeller boss radius is smaller than $0,2R$, and at the radius $0,25R$ where the propeller boss radius is greater than or equal to $0,2R$;

for detachable-blade propellers – at the radius $0,3R$ where the propeller boss radius is smaller than $0,3R$, and at the propeller boss radius where the propeller boss radius is larger than or equal to $0,3R$. The values of the factors A and c are adopted as in the case of $r = 0,25R$;

for CPP – at the radius $0,35R$ where the propeller boss radius is smaller than $0,35R$, at the propeller boss radius where the propeller boss radius is larger than or equal to $0,35R$.

Note. In the design section, the blade thickness is determined the fillets neglected.

In solid propellers, detachable-blade propellers and CPP, the maximum thickness s , in mm, of an expanded cylindrical section shall not be less than

$$s = 9,8 \left[A \sqrt{\frac{0,14kP}{zb\sigma n}} + c \frac{m}{\sigma} \left(\frac{Dn}{300} \right)^2 \right], \quad (6.2.1-1)$$

where A = coefficient to be determined by Formula (6.2.1-2) depending on the relative radius r/R of design section and the pitch ratio H/D at this radius (for a CP-propeller, take the pitch ratio of the basic design operating condition);

k = coefficient obtained from Table 6.2.1-1;

P = shaft power at the rated output of the main propulsion engine, kW;

z = number of blades;

b = width of the expanded cylindrical section of the blade on the design radius, m;

$\sigma = 0,6R_{mbl} + 175$ MPa, but not more than 570 MPa for steels and not more than 610 MPa for copper alloys;

R_{mbl} = tensile strength of blade material, MPa;

n = speed at the rated output, rpm;

c = coefficient of centrifugal stresses to be determined by Formula (6.2.1-3);

m = blade rake, mm;

D = propeller diameter, m;

$$A = \sum_{j=0}^4 \sum_{i=0}^3 a_{ij}(\bar{r})^i (H/D)^j, \quad (6.2.1-2)$$

where a_{ij} = factor determined from Table 6.2.1-2;

\bar{r} = relative radius of design section;

$$c = \sum_{i=0}^3 a_i(\bar{r})^i, \quad (6.2.1-3)$$

where a_i = factor determined from Table 6.2.1-3;

\bar{r} = relative radius of design section.

The holes for the items securing the blades of built-up and CP-propellers shall not reduce the design root section.

The thickness of propeller blades in ships of river-sea navigation and in ships of restricted areas of navigation **R2** and **R3** may be reduced by 5 per cent.

Table 6.2.1-1

| Ships without ice class | Ice class ships | | | | | | | Icebreakers | |
|-------------------------|-----------------|------|------|------|------|------|------------|------------------|--------------------------|
| | Ice1, Ice2 | Ice3 | Arc4 | Arc5 | Arc6 | Arc7 | Arc8, Arc9 | Centre propeller | Side propeller |
| 8 | 9 | 10 | 11,2 | 12,5 | 13,2 | 14 | 16 | 16 | $16 + \frac{23500}{P^1}$ |

¹ P = shaft power, kW.
 Notes: 1. If reciprocating engines with less than four cylinders are installed in the ship, k shall be increased by 7 per cent.
 2. For reciprocating engines fitted with hydraulic or electromagnetic couplings, k may be reduced by 5 per cent.
 3. For side propellers of ships without ice class and ships of ice classes **Ice1** and **Ice2**, k may be reduced by 7 per cent.

Table 6.2.1-2

| a_{ij} | | j | | | | |
|----------|---|--------------|---------------|---------------|---------------|---------------|
| | | 0 | 1 | 2 | 3 | 4 |
| i | 0 | 709,29796 | - 1988,09402 | 2866,42279 | - 2021,48724 | 547,82587 |
| | 1 | - 3780,43298 | 14440,53576 | - 22809,83724 | 16918,28525 | - 4715,66016 |
| | 2 | 9066,98223 | - 36165,14189 | 59184,72549 | - 45171,89303 | 12819,32337 |
| | 3 | - 7404,99029 | 29254,14486 | - 48753,36019 | 37837,58962 | - 10848,55838 |

Table 6.2.1-3

| | | Values of coefficient a_i | | | |
|-----|-------|-----------------------------|---------|------------|----------|
| i | | 0 | 1 | 2 | 3 |
| | a_i | 0,35 | 2,67381 | - 11,71429 | 10,47619 |

6.2.2 The blade tip thickness at the radius $D/2$ shall not be less than provided in [Table 6.2.2](#). The leading and trailing blade edge thickness measured at 0,05 of the blade width from the edges shall not be less than 50 per cent of blade tip thickness.

Table 6.2.2

| Ships without ice classes | Ships with ice classes | | | | Icebreakers |
|---------------------------|------------------------|-----------|----------|------------|-------------|
| | Ice1 – Arc5 | Arc6 | Arc7 | Arc8, Arc9 | |
| $0,0035D^1$ | $0,005D$ | $0,0055D$ | $0,006D$ | $0,008D$ | $0,008D$ |

¹ D = diameter of the propeller.

6.2.3 The blade thickness calculated in accordance with [6.2.1](#) and [6.2.2](#), may be reduced (e.g. for blades of particular shape), provided a detailed strength calculation is submitted for consideration to the Register.

6.2.4 The thickness of a high-skewed ($\theta > 25^\circ$) blade with an asymmetrical outline of the normal projection shall be checked in compliance with the requirements of [6.2.1](#).

Besides, the blade thickness at the radius $0,6R$ at a distance of $0,8$ of the width of section b not be less than determined from the following formula:

$$s_k = 0,4s(1 + 0,064\sqrt{\theta - 25}) , \quad (6.2.4)$$

where s = to be determined from Formula (6.2.1) at the radius $0,6R$;
 θ = angle, in degrees, equal to angle θ_1 or θ_2 , whichever is the greater (refer to Fig. 6.2.4).

If smoothness of the blade section profile at the radius $0,6R$ under condition of mandatory compliance with the requirements for the minimum thickness close to the trailing edge (on $0,8b$) is not provided, thickness s at the radius $0,6R$ is increased.

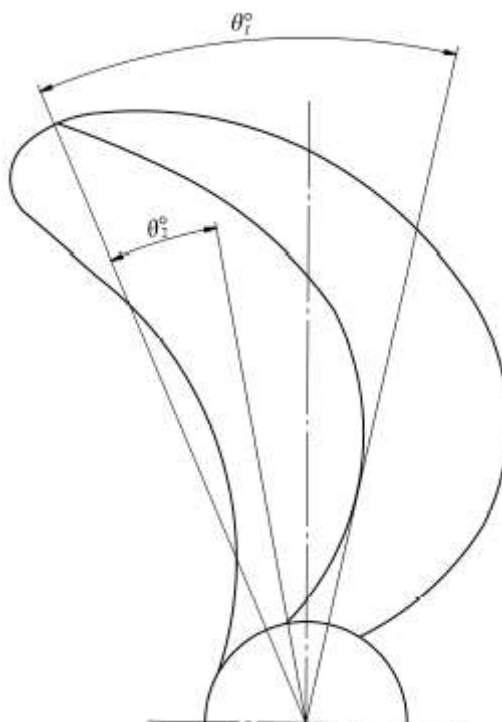

Fig. 6.2.4:

θ_1° = angle between the radius drawn through the blade tip and the radius tangent to the mid-chord;
 θ_2° = angle between radii drawn through the blade tip and root section centre of the blade

Use of high-skewed blades ($\theta > 5^\circ$) for icebreakers and ice ships of **Arc7** — **Arc9** categories and of high-skewed blades ($\theta > 10^\circ$) for ice ships of **Arc4** — **Arc6** categories shall be substantiated.

6.2.5 In icebreakers and ships provided with ice strengthening, the stresses in the most loaded parts of pitch control gear shall not exceed yield stress of the material, if the blade is broken in direction of the weakest section by a force applied along the blade axis over $2/3$ of its length from the boss and laterally over $2/3$ from the blade spindle axis to the leading edge.

6.3 PROPELLER BOSS AND BLADE FASTENING PARTS

6.3.1 Fillet radii of the transition from the root of a blade to the boss shall not be less than $0,04D$ on the suction side of the blade and shall not be less than $0,03D$ on the pressure side.

If the blade has no rake, the fillet radius on both sides shall be at least $0,03D$. Smooth transition from the blade to the boss using a variable radius may be permitted.

6.3.2 The propeller boss shall be provided with holes through which the empty spaces between the boss and shaft cone are filled with non-corrosive mass; the latter shall also fill the space inside the propeller cap.

6.3.3 The diameter of the bolts (studs), by which the blades are secured to the propeller boss or the internal diameter of the thread of such bolts (studs), whichever is less, shall not be less than that determined by the following formula:

$$D_b = ks \sqrt{\frac{bR_{mb}}{dR_{mb}}}, \quad (6.3.3)$$

where $k = 0,33$ = in case of three bolts in blade flange, at thrust surface;
 $0,30$ in case of four bolts in blade flange, at thrust surface;
 $0,28$ in case of five bolts in blade flange, at thrust surface;
 s = the maximum actual thickness of the blade at design root section (refer to [6.2.1](#)), mm;
 b = width of expanded cylindrical section of the blade at the design root section, m;
 R_{mb} = tensile strength of blade material, MPa;
 R_{mb} = tensile strength of bolt/stud material, MPa;
 d = diameter of bolt pitch circle; with other arrangement of bolts, $d = 0,85l$ where l = the distance between the most distant bolts, m.

6.3.4 The securing devices of the bolts (studs), by which the blades are fastened to the detachable-blade propellers of ice class ships, shall be recessed in the blade flange.

6.4 PROPELLER BALANCING

6.4.1 The completely finished propeller shall be statically balanced.

The extent of balancing shall be checked by a test load, which when suspended from the tip of every blade in horizontal position, shall cause the propeller to rotate. The mass of the test load shall not be more than

$$m \leq km_p/R, \quad (6.4.1)$$

where m = mass of test load, kg;
 m_p = mass of propeller, t;
 R = propeller radius, m;
 k = 0,75 for $n \leq 200$;
0,5 for $200 < n \leq 500$;
0,25 for $n > 500$;
 n = rated speed of propeller, rpm.

Where the propeller mass exceeds 10 t, the coefficient k shall not be greater than 0,5, irrespective of the propeller speed.

6.5 CONTROLLABLE PITCH PROPELLERS

6.5.1 The hydraulic power system of the controllable pitch propeller shall be supplied by two pumps of equal capacity, basic and standby, one of which may be driven from the main engine. The main engine driven pump shall provide turning of the blades under any operating mode of the main engines.

Where more than two pumps are available, their capacity shall be selected on the assumption that, if any of the pumps fails, the aggregate capacity of the rest would be sufficient to ensure the blade turning-over time not longer than stipulated by [6.5.5](#).

In ships with two CP-propellers one independent standby pump may be fitted for both CP-propellers.

6.5.2 The pitch control unit shall be designed so as to enable turning the blades into ahead speed position, shall the hydraulic power system fail.

In multi-screw ships, except icebreakers and ships with ice strengthening of categories **Arc5 — Arc9**, this requirement need not be satisfied.

6.5.3 In ships with a CP-propeller, in which the main engine may become overloaded due to particular service conditions, it is recommended that automatic protection against overloading be used for the main engine (refer to [3.2.1.9](#)).

6.5.4 The hydraulic power system of pitch control unit shall be constructed according to the requirements of Section 7, Part IX "Machinery", and the pipes shall be tested according to Section 21, Part VIII "Systems and Piping".

6.5.5 The time required for the blades to be turned over from full ahead to full astern speed position with main machinery inoperative shall not exceed 20 s for CP-propellers up to 2 m in diameter including, and 30 s for CP-propellers with diameters over 2 m.

6.5.6 In the gravity lubrication systems of CP-propellers, the gravity tanks shall be installed above the deepest load waterline and be provided with level indicators and low level alarms.

6.6 HYDRAULIC TESTS

6.6.1 The sealings fitted to the cone and flange casing of the propeller shaft (if such method of connection with the propeller boss is used) shall be tested to a pressure of at least 0,2 MPa after the propeller is fitted in place. If the above sealings are under pressure of oil from the sterntube or the propeller boss, they shall be tested in conjunction with testing of the sterntubes or propeller boss.

6.6.2 After being assembled with the blades the boss of a CP-propeller shall be tested by internal pressure equal to a head up to the working level of oil in gravity tank, or by a pressure created by the lubricating pump of the boss.

In general, the test shall be made during blade adjustment.

7 ACTIVE MEANS OF THE SHIP'S STEERING

7.1 GENERAL

7.1.1 The requirements of the present Section apply to steerable propellers with podded drives or with mechanical transmission of power to the propeller including retractable units of all types, waterjets, vertical-axis propellers, propellers in transverse tunnel (athwartship thrusters) and other devices of similar purpose.

7.1.2 Where AMSS is intended for main propulsion and steering of a ship, as a rule, minimum two AMSS shall be provided.

Provision in this case shall be made for control stations equipped with necessary devices and means of communication as indicated in [2.5](#), [3.1](#) — [3.3](#).

Where one AMSS is intended for main propulsion and steering of a ship, the technical substantiation shall be submitted to the Register for review.

7.1.3 The type and structure of AMSS shall be selected during ship design considering the ship purpose and area of navigation, as well as operational peculiarities.

7.1.4 The requirements for installation of AMSS machinery and equipment, materials and welding are given in [1.3](#), [2.4](#) and [4.4](#).

7.1.5 For AMSS intended for the main propulsion and for the dynamic positioning, size and materials of shafts, couplings, connection bolts, propellers, gearing as well as electrical equipment shall meet the requirements of relevant parts and sections of the RS Rules/C.

7.1.6 Calculations of the AMSS gearing shall be made following the procedure outlined in 4.2, Part IX "Machinery" or by other methods recognized by the Register. The safety factors of gearing shall not be less than those specified in 4.2, Part IX "Machinery". The values of these factors for the AMSS gearing intended for dynamic positioning duty shall be taken as for the main AMSS.

7.1.7 To support operating capacity of AMSS till special survey the service life of the rolling bearings shall be at least:

30000 h for the main AMSS;

10000 h for the AMSS used for dynamic positioning duty;

5000 h for the auxiliary AMSS.

7.1.8 Spaces containing the AMSS machinery shall be equipped with appropriate ventilating, fire extinguishing, drainage, heating and lighting arrangements.

7.2 CONSTRUCTION REQUIREMENTS

7.2.1 Steerable propellers shall be capable to be locked in all angular positions.

7.2.2 The main AMSS shall be provided with an emergency turning mechanism. The main AMSS angle indicator shall be provided. The difference between the indicated and actual positions shall comply with 2.9.16, Part III "Equipment, Arrangements and Outfit". The requirements of 6.1.4, Part IX "Machinery" shall be carried out.

7.2.3 For a ship fitted with multiple main AMSS, each of them shall be equipped with its own dedicated steering gear or other device to change the propeller angle.

7.2.4 Main AMSS of icebreakers and ships with ice categories **Arc4** — **Arc9** shall be provided with a device to prevent the ice overload of turning mechanism.

7.2.5 The strength of the parts of the main AMSS turning mechanism, casing components and securing items of the component parts, shafts, gearings, CPP components shall be so calculated that they can withstand without damage a load, which may cause breakdown of the propeller blade.

7.2.6 The strength of the parts of main AMSS turning mechanism, components for securing to ship's hull shall be so calculated that they can withstand hydrodynamic and ice loads acting upon the propeller, nozzle and AMSS casing without damage. It is permitted to determine hydrodynamic and ice loads on the AMSS components according to the results of hydrodynamic tests and testing of self-propelled models in the ice model basin according to the procedures approved by the Register.

7.2.7 The ability of the machinery to change the thrust direction for stopping the ship making a full ahead speed on an agreeable distance shall be proven and recorded.

The steerable propeller designed for reversing the thrust by turning the unit shall provide an acceptable reversing time depending on the purpose of the ship. The time required for turning the unit through 180° shall not then exceed 20 s for the units with a propeller of 2 m and less in diameter and shall not exceed 30 s for the units with a propeller of more than 2 m in diameter.

7.2.8 Sealing boxes of a type approved by the Register shall be installed to prevent seawater from gaining access to internal parts of the AMSS. For the main and for the dynamic positioning AMSS such sealing arrangement shall contain at least two separate, closely effective sealing elements.

7.2.9 An easy access shall be provided to component parts of the AMSS to allow their maintenance within the scope stipulated by the Service Manual.

7.2.10 Where the design of the main AMSS does not insure against free rotation of the propeller and shafting in case of failure of the prime mover and such rotation may cause damage to the propulsion systems, the provisions shall be made for a braking device in accordance with the requirements of [5.8](#) (refer also to 17.3.4, Part XI "Electrical Equipment").

On agreement with the Register, braking devices for the AMSS intended for the dynamic positioning and for the auxiliary AMSS may be dispensed with.

7.2.11 For technical condition monitoring of the main AMSS in service, they may be fitted with control facilities considering the requirements of Section [9](#) and Section [10](#). The technical condition monitoring system shall combine functions of built-in (fixed) systems and portable control facilities.

A list of the technical condition monitoring system equipment, controlled parameters and frequency of their measurements, as well as standards of technical condition of the AMSS control items are developed by manufacturers and/or suppliers of the equipment.

Technical substantiation of required control of the main AMSS shall be agreed upon with the Register in each particular case.

7.2.12 The steerable propellers with podded drives shall be free of restricted speed ranges due to torsional vibrations within the entire operating speed range.

7.3 ALARMS

7.3.1 The AMSS shall be at least provided with alarms to be operated in the event of the following faults:

- .1** overload and emergency stop of prime mover;
- .2** power failure in remote control and alarm system;
- .3** low level in lubricating oil tank (if provided);
- .4** low lubricating oil pressure (if forced lubricating oil system);
- .5** low oil level in hydraulic supply system for turning steerable propellers and CP-propeller blades;
- .6** low oil level in head tank for sealing arrangements;
- .7** high level in bilge wells of the hull and AMSS spaces.

7.3.2 Individual indication units shall be provided on the bridge for:

- .1** overload of prime mover AMSS and servo mover for steerable propellers (if no automatic protection is provided);
- .2** frequency of the propeller rotation, vertical-axis propeller or water jet impeller;
- .3** blade turning angle or propeller pitch for CP-propeller plants;
- .4** direction of thrust for fixed propeller plants, vertical-axis propeller or water jet;
- .5** angular position of steerable propeller, water jet steering and reversing gear or vertical-axis propeller eccentricity;
- .6** available power in the alarm system.

7.3.3 For auxiliary AMSS the number of parameters covered by the alarm system and indicator units may be reduced subject to agreement with the Register.

7.4 ARRANGEMENTS FOR STEERING CAPABILITY

7.4.1 The stopping times, ship headings and distances recorded on trials, together with the results of trials to determine the ability of ships having multiple propulsion/steering arrangements to navigate and manoeuvre with one or more propellers inoperative, shall be available on board for the use of the master or designated personnel.

7.4.2 For ship fitted with main multiple steering propulsion units, such as but not limited to steerable propellers or water jet propulsion systems, each of steering propulsion units shall be equipped with the following:

either main and auxiliary steering gear;

or with two or more identical steering actuating systems capable of satisfying the requirements of [7.4.8](#).

The main steering gear and the auxiliary steering gear shall be so arranged that the failure of one of them will not render the other one inoperative.

7.4.3 For ship fitted with a single steering propulsion unit, it shall be equipped with two or more steering actuating systems capable of satisfying the requirements of [7.4.7](#).

A detailed risk assessment is to be submitted in order to demonstrate that in the case of any single failure in the steering gear, control system and power supply the ship steering is maintained.

7.4.4 All components used in the steerable propeller or other devices of the main steering arrangements provided for changing the propeller angle for ship directional control shall be of adequate strength as required by relevant calculations considering [7.1.5](#).

All essential components used in steering arrangements for ship directional control shall be duplicated.

When not duplicated or when the RS Rules/C contain no requirements for particular AMSS components, possibility of using them shall be agreed upon with the Register.

All essential component shall, where appropriate, utilize anti-friction bearings such as ball bearings, roller bearings or sleeve bearings which shall permanently lubricated or provided with lubrication fittings.

7.4.5 The main steering arrangements for ship directional control shall be:

.1 of adequate strength and capable of steering the ship at maximum ahead service speed which shall be demonstrated;

.2 capable of changing direction of the ship's directional control system from one side to the other at declared steering angle limits at an average rotational speed of not less than 2,3 °/s with the ship running ahead at maximum ahead service speed;

.3 for all ships, operated by power;

.4 so designed that they will not be damaged at maximum astern speed.

Note. Declared steering angle limits (also refer to 2.9.2 and 2.9.3 of Part III "Equipment, Arrangements and Outfit") are the operational limits in terms of maximum steering angle, or equivalent, according to manufacturer's guidelines for safe operation, also taking into account ship's speed or propeller torque/speed or other limitation. The declared steering angle limits shall be declared by the directional control system manufacturer for each AMSS. Ship's manoeuvrability tests (considering IMO resolution MSC.137(76)) shall be carried out with steering angles not exceeding the declared steering angle limits.

7.4.6 The auxiliary steering arrangements for ship directional control shall be:

.1 of adequate strength and capable of steering the ship at navigable speed and of being brought speedily into action in an emergency;

.2 capable of changing direction of the ship's directional control system from one side to the other at declared steering angle limits at an average rotational speed, of not less

than 0,5 °/s; with the ship running ahead at one half of the maximum ahead service speed or 7 knots (whichever is the greater);

.3 for all ships, operated by power where necessary to meet the requirements of [7.4.6.2](#) and in any ship having power of more than 2,500 kW propulsion power per thruster unit.

Note. Declared steering angle limits (also refer to 2.9.2 and 2.9.3 of Part III "Equipment, Arrangements and Outfit") are the operational limits in terms of maximum steering angle, or equivalent, according to manufacturer's guidelines for safe operation, also taking into account the ship's speed or propeller torque/speed or other limitation. The declared steering angle limits shall be declared by the directional control system manufacturer for each AMSS. Ship's manoeuvrability tests (considering IMO resolution MSC.137(76)) shall be carried out with steering angles not exceeding the declared steering angle limits.

7.4.7 For a ship fitted with a single steering propulsion unit where the main steering gear comprises two or more identical power units, an auxiliary steering gear need not be fitted, provided that:

.1 in a passenger ship, the main steering gear is capable of operating the rudder as required by [7.4.5](#) while any one of the power units is out of operation;

.2 in a cargo ship, the main steering gear is capable of operating the rudder as required by [7.4.5](#) while operating with all power units;

.3 the main steering gear is arranged so that after a single failure in its piping system or in one of the power units the defect can be isolated so that steering capability can be maintained or speedily regained.

Note. Steering gear power unit – for the purposes of non-electric (alternative) steering arrangements, the steering gear power unit shall be considered as defined in 1.2.9 of Part III "Equipment, Arrangements and Outfit". For electric steering gears refer to 1.2.9 of Part III "Equipment, Arrangements and Outfit", electric steering motors shall be considered as part of power unit and actuator.

7.4.8 For a ship fitted with multiple steering propulsion units, where each main steering system comprises two or more identical steering actuating systems, an auxiliary steering arrangements need not be fitted, provided that:

.1 in a passenger ship, each steering gear is capable of operating the ship's directional control system as required by [7.4.5](#), while any one of the steering gear steering actuating systems is out of operation;

.2 in a cargo ship, each steering gear is capable of operating the ship's directional control system as required by [7.4.5](#) while operating with all steering gear steering actuating systems;

.3 each steering gear is arranged so that after a single failure in its piping or in one of the power units the defect can be isolated so that steering capability can be maintained or speedily regained. The above capacity requirements apply regardless whether the steering systems are arranged with common or dedicated power units.

Note. Steering gear power unit – for the purposes of non-electric (alternative) steering arrangements, the steering gear power unit shall be considered as defined in 1.2.9 of Part III "Equipment, Arrangements and Outfit". For electric steering gears refer to 1.2.9 of Part III "Equipment, Arrangements and Outfit", electric steering motors shall be considered as part of power unit and actuator.

7.4.9 The requirements of this para apply to the steering systems having a certain proven steering capability due to ship speed also in case propulsion power has failed.

Where the propulsion power exceeds 2500 kW per thruster unit, an alternative power supply, sufficient at least to supply the steering arrangements which complies with the requirements of [7.4.6.2](#) and also its associated control system and the steering system response indicator, shall be provided automatically, within 45 s, either from the emergency source of electrical power or from an independent source of power located in the steering gear compartment. This independent source of power shall be used only for this purpose.

In every ship of 10000 gross tonnage and upwards, the alternative power supply shall have a capacity for at least 30 min of continuous operation and in any other ship for at least 10 min.

7.4.10 For a ship fitted with multiple steering systems the requirements of 5.5.2 and 5.5.3 of Part XI "Electrical Equipment" shall be carried out for each AMSS.

7.5 HYDRAULIC TESTS

7.5.1 Once assembled, the internal parts of the unit casing shall be subjected to test hydraulic pressure corresponding to the maximum operational depth of immersion with an allowance made for the overpressure of the sealing arrangements. For water-jet propellers pressure generated by water head shall be considered in case of reversing.

7.5.2 Once installed, the sealing arrangements shall be subjected to leak testing by pressure equal to the height of a liquid column in head tanks at an operational level.

7.5.3 In addition, it may be necessary to carry out non-destructive testing of welds on the steerable propeller components and other welded structures within the scope of requirements set forth in Part XIV "Welding".

8 TORSIONAL VIBRATION

8.1 GENERAL

8.1.1 This Section applies to propulsion plants with the main engines having a power of not less than 75 kW when ICE is used and of not less than 110 kW when using turbo or electric drives, and to main and auxiliary diesel generators as well as to ICE-driven machinery having a primary engine power of not less than 110 kW, as well as main and auxiliary diesel generators and auxiliary machinery driven by ICE with not less than 110 kW power.

8.1.2 Torsional vibration calculations shall be prepared both for the basic variant and for other variants and conditions possible in the operation of the installation, as follows:

- .1 maximum power take-off and idling speed (with the propeller blades at zero position) for installations comprising CP-propellers or vertical axis propellers;
- .2 individual and simultaneous operation of main engines with a common reduction gear;
- .3 reverse gear (propulsion plant reversing mode);
- .4 connection of additional power consumers if their moments of inertia are commensurate with the inertia moments of the working cylinder;
- .5 running with one cylinder missfiring, for installations containing flexible couplings and reduction gear; to be assumed not firing is the cylinder the disconnection of which accounts to the greatest degree for the increase of stresses and alternating torques;
- .6 damper jammed or removed where single main engine installations are concerned;
- .7 flexible coupling blocked due to breakage of its elastic components (where single main engine installations are concerned).

The steerable propellers with podded drives with respect to torsional vibrations shall all comply with [7.2.12](#), which shall be indicated in the technical documentation submitted for consideration to the Register. In this case, the submission of a separate torsional vibration calculations is not required.

8.1.3 For ships of restricted area of navigation **R3**, calculations stipulated by [8.1.2.6](#) and [8.1.2.7](#) are not necessary. No calculations shall be submitted if it is documented that the installation is similar to that approved earlier or that its mass inertia moments and torsion stiffness between masses do not differ from the basic ones by 10 % and 5 % accordingly or the calculation may be limited to determination of the natural frequencies if at this stage of the calculation it is established that the differences in the mass inertia moments and torsion stiffness between masses do not result in change of the natural frequency of any one of the modes under consideration by more than 5 %.

8.1.4 Torsional vibration calculations shall include:

- .1 details of all the installation components: particulars of engine, propeller, damper, flexible coupling, reduction gear, generator, etc.;
speeds corresponding to the principal long-term operating conditions specified for operation under partial loads (half speed, slow speed, dead slow speed, trawling operation, zero-speed operation for installations comprising CP-propellers, main diesel generator conditions, etc.);
layouts of all installation operating conditions possible;
initial data for the design torsional diagram of the installation;
- .2 natural frequency tables for all basic modes of vibration having a resonance up to the 12th order inclusive within the speed range $(0 - 1,2)n_r$ with relative vibration amplitudes of masses and moments, and with scales of stresses (torques) for all sections of the system;
- .3 for each order of all vibration modes under consideration:
resonance vibration amplitudes of the first mass of the system;

resonance stresses (torques) in all the system components (shafts, reduction gear, couplings, generators, compression or compression-key joints, etc.) and temperatures of the rubber components of flexible couplings as compared to relevant permissible values;

.4 total stresses (torques), where it is necessary to consider the simultaneous effect of disturbing moments of several orders, as compared to relevant permissible values;

.5 stress (torque) curves for the principal sections of the system with indication of permissible values for continuous running and rapid passage and of restricted speed ranges where these are assigned;

.6 conclusions based on the results of calculation.

8.1.5 The alternating torsional stress amplitude is understood as $(\tau_{max} - \tau_{min})/2$ as it can be measured on a shaft in a relevant condition over a repetitive cycle.

8.1.6 The diesel generators installed on ships shall show torsional vibration levels which are verified (considering the structure) and are compatible with the allowable limits for the alternator, shafts, coupling and damper. Herewith, the rated power used at calculations shall be appropriate for the actual use of the diesel generator; coupling shall be selected considering stresses and torques resulted from torsional vibrations of the system.

8.2 PERMISSIBLE STRESSES FOR CRANKSHAFTS

8.2.1 For main engine crankshafts of icebreakers and of ships with ice categories **Arc4** — **Arc9** within the speed range (0,7 — 1,05) n_r and for main engine crankshafts of other types of ships and the crankshafts of engines driving generators and other auxiliary machinery for essential services within the speed range (0,9 — 1,05) n_r the total stresses due to torsional vibration under conditions of continuous running shall not exceed the values determined by the following formulas:

when calculating a crankshaft in accordance with 2.4.5, Part IX "Machinery",

$$\tau_C = \pm \tau_N ; \quad (8.2.1-1)$$

when calculating a crankshaft by another method,

$$\tau_C = \pm 0,76 \frac{R_m + 160}{18} C_d ; \quad (8.2.1-2)$$

within speed ranges lower than indicated

$$\tau_C = \pm \frac{\tau_N [3 - 2(n/n_r)^2]}{1,38} \quad (8.2.1-3)$$

or

$$\tau_C = \pm 0,55 \frac{R_m + 160}{18} C_d [3 - 2(n/n_r)^2], \quad (8.2.1-4)$$

where τ_C = permissible stresses, MPa;

τ_N = maximum alternating torsional stress determined during crankshaft calculation from Formula (2.4.5.1), Part IX "Machinery" for the maximum value of W_p ;

R_m = tensile strength of shaft material, MPa. When using materials with the tensile strength above 800 MPa, $R_m = 800$ MPa shall be adopted for calculation purposes;

n = speed under consideration, rpm. For tugs, trawlers and other ships which main engines run continuously under conditions of maximum torque at speeds below the rated speed throughout the speed range, $n = n_r$ shall be adopted and Formulas (8.2.1-1) and (8.2.1-2) shall be used. For the main diesel generators of ships with electric propulsion plants, all the specified values of n_r shall, by turn, be adopted as n , and in each of the ranges (0,9 – 1,05) n_r , Formulas (8.2.1-3) and (8.2.1-4) shall be used for partial loads;

n_r = rated speed, rpm;

C_d = $0,35 + 0,93d^{-0,2}$ – scale factor;

d = shaft diameter, mm.

8.2.2 The total stresses due to torsional vibration within speed ranges prohibited for continuous running, but which may only be rapidly passed through shall not exceed the values determined by the following formulas:

for the crankshafts of main engines

$$\tau_T = 2\tau_C ; \quad (8.2.2-1)$$

for the crankshafts of engines driving generators or other auxiliary machinery for essential services

$$\tau_T = 5\tau_C , \quad (8.2.2-2)$$

where τ_T – permissible stresses for speed ranges to be rapidly passed through, MPa;

τ_C – permissible stresses determined by one of Formulas (8.2.1-1) to (8.2.1-4).

8.3 PERMISSIBLE STRESSES FOR INTERMEDIATE, THRUST, PROPELLER SHAFTS AND GENERATOR SHAFTS

8.3.1 Under conditions of continuous running, the total stresses due to torsional vibration shall not exceed the values determined by the formulas:

for the shafts of icebreakers and **Arc4** — **Arc9** ice class ships within the speed range (0,7 — 1,05) n_r , and for the shafts of all other ships and generator shafts within the speed range (0,9 — 1,05) n_r

$$\tau_C = \pm 1,38 \frac{R_m + 160}{18} C_k C_d ; \quad (8.3.1-1)$$

within speed ranges lower than indicated

$$\tau_C = \pm \frac{R_m + 160}{18} C_k C_d [3 - 2(n/n_r)^2] , \quad (8.3.1-2)$$

where R_m = tensile strength of the shaft material, MPa. When using the material with the tensile strength over 800 MPa (for intermediate and thrust shafts of alloyed steel) and over 600 MPa (for intermediate and thrust shafts of carbon and carbon-manganese steel, as well as for propeller shaft) $R_m = 800$ MPa and $R_m = 600$ MPa shall be assumed in the calculations accordingly;

C_k = factor obtained from [Table 8.3.1](#);

for C_d , refer to [8.2.1](#).

Table 8.3.1

| Coefficient C_k | | |
|---|--|-------------------|
| Structural shaft type | | C_k |
| Intermediate shaft, thrust shaft in external thrust bearing outside the area of roller bearing or the collar area, generator shaft | with integral coupling flanges or shrink fit couplings ¹ | 1,0 |
| | with a radial hole (refer to 5.2.7) | 0,50 |
| | with a taper joint keyway (refer to 5.2.9) | 0,60 |
| | with a cylindrical joint keyway (refer to 5.2.9) | 0,45 |
| | with a longitudinal slot (refer to 5.2.8) | 0,30 ² |
| Thrust shaft in way of the collar or the roller thrust bearing (refer to 5.2.2) | | 0,85 |
| Propeller shaft | forward sections ($k=1,15$, refer to 5.2.3) | 0,80 |
| | sections in way of the aft stern-tube bearing and propeller ($k=1,22$; $k=1,26$, refer to 5.2.3) | 0,55 |
| ¹ when shafts may experience vibratory stresses close to the permissible stresses for continuous operation, the diameter increase in the compression joint shall be provided. ² other C_k value may be substantiated and calculated. $C_k = 1,45/scf$, where scf is defined as the ratio between the maximum local principal stress and $\sqrt{3}$ times the nominal torsional stress (determined for the bored shaft without slots). | | |

8.3.2 The total stresses due to torsional vibration within speed ranges prohibited for continuous running, but which may only be rapidly passed through shall not exceed:

for intermediate, thrust, propeller shafts and shafts of generators driven by the main engine

$$\tau_T = \frac{1,7\tau_C}{\sqrt{C_k}} ; \quad (8.3.2)$$

for the shafts of generators driven by auxiliary engines, the value determined by Formula ([8.2.2-2](#)).

8.4 PERMISSIBLE TORQUE IN REDUCTION GEAR

8.4.1 For the case of continuous running or rapid passage, the alternating torques in any reduction gear step shall not exceed the permissible values established for the operating conditions by the manufacturer.

8.4.2 Where the values mentioned under [8.4.1](#) are not available, the alternating torque in any reduction gear step for the case of continuous running shall satisfy the following conditions:

within the speed range $(0,7 — 1,05) n_p$ – for the main propulsion plants of icebreakers and ice class ships **Arc4** — **Arc9** and $(0,9 — 1,05) n_p$ – for other ships,

$$M_{alt} \leq 0,3M_{nom}; \quad (8.4.2-1)$$

within speed ranges lower than indicated, the permissible value of alternating torque calculations shall be submitted to the Register review but in any case:

$$M_{alt} \leq 1,3M_{nom} - M, \quad (8.4.2-2)$$

where M_{nom} = average torque in the step under consideration at nominal speed, N/m;
 M = average torque at the speed under consideration, N/m.

For the case of rapid passage, the alternating torque value shall also be submitted to the Register review.

8.5 PERMISSIBLE TORQUE AND TEMPERATURE OF FLEXIBLE COUPLINGS

8.5.1 For the case of continuous running or rapid passage, the alternating torque in a coupling, relevant stresses in and temperatures of the flexible component material due to torsional vibration shall not exceed the permissible values established for the operating conditions by the manufacturer.

8.5.2 Where the values mentioned under [8.5.1](#) are not available, the torque, stress and temperature values permissible for continuous running and rapid passage shall be determined by the procedures approved by the Register.

8.6 OTHER INSTALLATION COMPONENTS

8.6.1 Under conditions of continuous running, the total torque (average torque plus alternating torque) shall not exceed the frictional torque in the keyless fitting of the propeller and shaft or shafting couplings.

8.6.2 Where, for generator rotors, the manufacturer's permissible values are not available, the alternating torque shall not exceed twice, in the case of continuous running, or six times, in the case of rapid passage, the nominal generator torque.

8.7 TORSIONAL VIBRATION MEASUREMENT

8.7.1 Data obtained from torsional vibration calculations for machinery installations with the main engines shall be confirmed by measurements except for steerable propellers with podded drives (refer to [7.2.12](#) and [8.1.2](#)). The measurements shall cover all the variants and operation conditions of the installation, for which calculations were made in accordance with [8.1.2](#), except emergency operation conditions listed in [8.1.2.6](#) and [8.1.2.7](#).

In well-grounded cases, the Register may require torsional vibrations to be measured in auxiliary diesel generators and ICE-driven auxiliary machinery for essential services.

8.7.2 The results of measurement obtained on the first ship (unit) of a series apply to all the ships (units) of that series, provided their engine-shafting-propeller (driven machinery) systems are identical.

8.7.3 The free resonance vibration frequencies obtained as a result of measurement shall not differ from the design values by more than 5 per cent. Otherwise, the calculation shall be corrected accordingly.

8.7.4 The stresses shall be determined proceeding from the greatest vibration or stress amplitudes measured in the respective section of the torsiongram or oscillogram.

When estimating the total stresses due to vibration of several orders, the registered parameters shall undergo harmonic analysis.

8.8 RESTRICTED SPEED RANGES

8.8.1 Where the shaft stresses, torques in some installation components or temperature of the rubber components of flexible couplings arising due to torsional vibration exceed the relevant permissible values for continuous running determined in accordance with [8.2.1](#), [8.3.1](#), [8.4](#) — [8.6](#), restricted speed ranges are assigned.

8.8.2 No restricted speed ranges are permitted for the following speeds:

$n \geq 0,7n_r$ with respect to icebreakers and **Arc4** — **Arc9** ice class ships;

$n \geq 0,8n_r$ with respect to other ships;

$n \geq (0,9 - 1,05)n_r$ with respect to diesel generators and other auxiliary diesel machinery for essential services. Where the main diesel generators of ships with electric propulsion plants are concerned, all the fixed speed values corresponding to the specified conditions of partial loading shall alternately be adopted for n_r .

In icebreakers and **Arc7** — **Arc9** ice class ships fitted with a FPP, blade frequency resonance is recommended to be avoided within the range $(0,5 - 0,8) n_r$.

Barred speed range with one cylinder misfiring in case of one main engine on board the ship shall not influence the ship's steerability.

8.8.3 If all the other methods of lowering stresses (torques) due to torsional vibration prove ineffective, a vibration damper or antivibrator may be fitted where the values permitted by [8.2](#) — [8.6](#) are exceeded:

in the case of continuous running, within speed ranges where restricted speed range is not permitted or undesirable;

in the case of rapid passage, in any point of the speed range $(0 - 1,2) n_r$.

8.8.4 The vibration damper or antivibrator shall ensure lowering of stresses (torques) by not less than 85 % of the relevant permissible values at the resonance to which it is adjusted.

8.8.5 For icebreakers and **Arc4** — **Arc9** ice class ships within the main engine speed range $(0,7 - 1,05) n_r$ and for other ships and diesel generators within the speed range $(0,9 - 1,05) n_r$, vibration dampers or antivibrators may be used to eliminate restricted speed ranges shall be agreed upon with the Register.

8.8.6 A restricted speed range is established proceeding from the speed range, in which the stresses (torques, temperature) exceed the permissible values increased by 0,02 of n_{res} on both sides (with regard to tachometer tolerance). The engine shall be stable in operation at the barred range boundaries.

For calculation purposes, the restricted speed range borders may be determined by the following formula:

$$\frac{16n_{res}}{18-n_{res}/n_r} \leq n \leq \frac{(18-n_{res}/n_r)n_{res}}{16}, \quad (8.8.6)$$

where n_{res} = resonance speed, rpm.

For CPP with the possibility of individual pitch and speed control, both full and zero pitch conditions shall be considered.

8.8.7 Restricted speed ranges shall be marked off on the tachometer in accordance with [2.5.2](#).

Information on restricted speed ranges and their borders shall be made available on plates fastened at all the stations, from which the installation may be controlled.

8.8.8 For the case of remote control of the main machinery from the wheelhouse, the requirements of 4.2.2.4, Part XV "Automation" shall be complied with.

9 VIBRATION OF MACHINERY AND EQUIPMENT. VIBRATION STANDARDS

9.1 GENERAL

9.1.1 This Section sets down the limits of vibration levels (vibration standards) for ships machinery and equipment.

9.1.1.1 The standards are intended to determine whether actual vibration levels in machinery and equipment installed onboard the ships during construction (after repair) and ships in service are permissible proceeding from vibration parameter measurements. The vibration standards provide three categories of technical condition of ship machinery and equipment:

A – condition of machinery and equipment after manufacturing (construction of the ship) or repair at the commissioning;

B – condition of machinery and equipment during normal operation;

C – condition of machinery and equipment when technical maintenance or repair is required.

The standards determine the upper limits of categories *A* and *B*.

9.1.1.2 For machinery and equipment, not mentioned in this section but affecting the safe operation of the ship, if it is required to assess their levels of vibration, one shall be guided by the standards specified by the manufacturer, or applicable national and international standards.

Manufacturer of ships machinery and equipment may apply other standards provided convincing data are available that the product is capable of operating under other vibration conditions.

9.1.2 Vibration measurements shall be taken on all the first ships of a series being built at each shipyard, on the first ship of modified design, on the single buildings and on the ships undergone conversion.

Vibration measurements of machinery and equipment shall be taken during construction of the ship according to the program approved by the Register in compliance with the instructions of 18.6 of the Guidelines on Technical Supervision of Ships under Construction.

9.1.3 During construction of the ship (or after repair) the vibration level of the machinery and equipment shall not exceed the upper limit of category *A*, determined as to ensure sufficient margin for changing of vibration level in operation.

Under conditions of long-term service of the ship the vibration level of the machinery and equipment shall not exceed the upper limit of category *B*, determined as to ensure vibration strength and reliability of ship machinery and equipment.

9.1.4 The measurement results shall be compared with the permissible vibration levels.

Where vibration exceeds the standards, measures shall be taken to reduce it to permissible level.

9.1.5 Vibration levels of machinery and equipment shall not exceed the standards both when the ships is lying and at specified ahead speeds under different loading conditions.

At non-specified rates of speed vibration exceeding established standards may be permitted, when these rates are not continuous.

9.1.6 In case of withdrawal from the present standards the technical substantiation shall be submitted to the Register review.

9.1.7 Designing shall be carried out considering IACS recommendation No. 167 (Corr.1, Mar 2021).

9.2 STANDARDIZED VIBRATION PARAMETERS

9.2.1 The root-mean square value of vibration rate, measured in 1/3-octave band, is assumed as the basic vibration parameter. Standardized root-mean square values of vibration rate in frequency band 2 — 1000 Hz indicated in the normative documents for specified machinery and equipment, are assumed as an additional parameter for vibration control. Measuring of vibration in octave band is allowed.

9.2.2 Alongside with the vibration rate the root-mean square value of vibration acceleration may also be a parameter measured.

9.2.3 Vibration parameters are measured in absolute units or in decibels relatively to standard limiting values of speed or acceleration being equal to 5×10^{-5} , mm/s, and 3×10^4 , m/s², accordingly.

Conversion of the measured values of vibration rate into relative units shall be made using the formula

$$L = 20 \lg \frac{V_e}{V_{eo}}, \quad (9.2.3)$$

where V_e the measured root-mean square value of vibration rate, mm/s;

$$V_{eo} = 5 \times 10^{-5} \text{ mm/s.}$$

9.2.4 When vibration is measured in octave bands, the permissible values of the parameter measured may be increased by $\sqrt{2} =$ times (3 dB) as compared to those stated in [9.3](#) — [9.8](#) for bands with geometric mean frequency values of 2; 4; 8; 16; 31,5; 63; 125; 250 and 500 Hz.

9.2.5 Measurements of vibration of the machinery and equipment shall be taken for each of the three inter-perpendicular direction about the ship axes: vertical, horizontal-transverse and horizontal-longitudinal. For internal combustion engines, measurements of vibration shall be taken according to direction of axes: *X* – axial (coincident with the direction of the crankshaft), *Y* – horizontal-transverse, *Z* – vertical. Such designation shall be applied for main diesel engines and diesel engines of diesel-generators. The points of vibration measuring are indicated in [Figs. 9.2.5](#), [9.8.1](#) and [9.9.1](#).

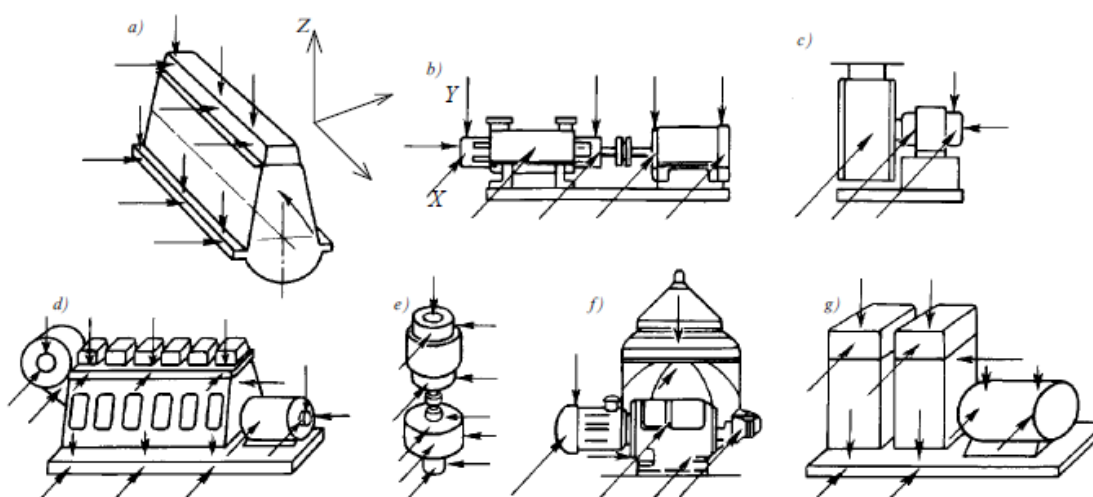

Fig. 9.2.5

Points of vibration measuring:

a – internal combustion engine; *b* – horizontal pump; *c* – fan; *d* – diesel-generator; *e* – vertical pump; *f* – separator; *g* – piston compressor.

The points and directions of vibration measurement are shown by arrows

9.2.6 Vibration standards of machinery are specified in the relative chapters for rigid and yielding supports to which machinery can be attached under shipboard conditions.

Rigid supports are those supports where the first natural frequency of the "support – machinery" system exceeds the basic exciting frequency (working frequency of revolution) in the vibration measurement direction by more than 25 %.

Yielding support is a support where the first natural frequency is less than 25 % of the machinery working frequency of revolution.

Yielding of the support is ensured by resilient mounting of the machinery or support (vibration insulators of various design – shock absorbers, springs, rubber insulators, etc.).

The vibration standards of categories *A* and *B* for machinery installed on rigid supports are specified in the relevant tables and figures. When the machinery is attached to yielding supports, the values of permissible vibration standards are increased. To determine the values of permissible vibration rate, multiplication factor for the particular type of machinery shall be applied.

9.3 VIBRATION STANDARDS FOR INTERNAL COMBUSTION ENGINES

9.3.1 Vibration standards are extended to cover ICE with 55 kW and above in power and rotation frequency $\leq 3000 \text{ min}^{-1}$.

9.3.2 Vibration of low-speed internal combustion engines installed on rigid supports is considered permissible for categories *A* and *B*, provided the root-means square values of vibration rate and vibration acceleration measured in the direction of axes *x* and *z* do not exceed the values specified in [Table 9.3.2](#). When vibration is measured along the axis *y* (in horizontal-transverse direction) the permissible vibration rate standards for categories *A* and *B* shall be increased by 1,4 times.

When the internal combustion engines are installed on yielding supports (main medium-speed diesel engines and diesel engines of diesel-generators) the permissible vibration standards for categories *A* and *B* in the direction of axes *x*, *y* and *z*, specified in [Table 9.3.2](#) shall be increased by 1,4 times.

9.3.3 Vibration of machinery and devices hung on ICE shall not exceed the levels given in [9.3.2](#).

9.3.4 Vibration of turbo-compressors measured on bearing housings is considered permissible for categories *A* and *B*, provided the root-meansquare values of vibration rate or vibration acceleration do not exceed the values specified in [Table 9.3.4](#).

Table 9.3.2

Vibration standards for internal combustion engines

| Geometric mean frequencies of 1/3-octave bands, Hz | Engines with piston stroke, cm | | | | | | | | | | | | | | | | | | | |
|--|--------------------------------------|------|------------|------|------------|------|------------|------|------------|------|------------|------|------------|------|------------|------|------------|------|------------|-----|
| | under 30 | | | | 30 to 70 | | | | 71 to 140 | | | | 141 to 240 | | | | over 240 | | | |
| | Permissible values of vibration rate | | | | | | | | | | | | | | | | | | | |
| | category A | | category B | | category A | | category B | | category A | | category B | | category A | | category B | | category A | | category B | |
| mm/s | dB | mm/s | dB | mm/s | dB | mm/s | dB | mm/s | dB | mm/s | dB | mm/s | dB | mm/s | dB | mm/s | dB | mm/s | dB | |
| 1,6 | 4 | 98 | 5,6 | 101 | 4 | 98 | 5,6 | 101 | 4 | 98 | 5,6 | 101 | 4 | 98 | 5,6 | 101 | 4 | 98 | 5,6 | 101 |
| 2 | 4 | 98 | 5,6 | 101 | 4 | 98 | 5,6 | 101 | 4 | 98 | 5,6 | 101 | 4 | 98 | 5,6 | 101 | 4,5 | 99 | 6,3 | 102 |
| 2,5 | 4 | 98 | 5,6 | 101 | 4 | 98 | 5,6 | 101 | 4 | 98 | 5,6 | 101 | 4,6 | 99 | 6,3 | 102 | 5,6 | 101 | 8,0 | 104 |
| 3,2 | 4 | 98 | 5,6 | 101 | 4 | 98 | 5,6 | 101 | 4,5 | 99 | 6,3 | 102 | 5,6 | 101 | 8,0 | 104 | 7,1 | 103 | 10 | 106 |
| 4 | 4 | 98 | 5,6 | 101 | 4,5 | 99 | 6,3 | 102 | 5,6 | 101 | 8,0 | 104 | 7,1 | 103 | 10 | 106 | 8,9 | 105 | 12,5 | 108 |
| 5 | 4,5 | 99 | 6,3 | 102 | 5,6 | 101 | 8,0 | 104 | 7,1 | 103 | 10 | 106 | 8,9 | 105 | 12,5 | 108 | 11 | 107 | 16 | 110 |
| 6,3 | 5,6 | 101 | 8,0 | 104 | 7,1 | 103 | 10 | 106 | 8,9 | 105 | 12,5 | 108 | 11 | 107 | 16 | 110 | 14 | 109 | 20 | 112 |
| 8 | 7,1 | 103 | 10 | 106 | 8,9 | 105 | 12,5 | 108 | 11 | 107 | 16 | 110 | 14 | 109 | 20 | 112 | 16 | 110 | 22 | 113 |
| 10 | 8,9 | 105 | 12,5 | 108 | 11 | 107 | 16 | 110 | 14 | 109 | 20 | 112 | 16 | 110 | 22 | 113 | 16 | 110 | 22 | 113 |
| 12,5 | 11 | 107 | 16 | 110 | 14 | 109 | 20 | 112 | 16 | 110 | 22 | 113 | 16 | 110 | 22 | 113 | 16 | 110 | 22 | 113 |
| 16 | 14 | 109 | 20 | 112 | 16 | 110 | 22 | 113 | 16 | 110 | 22 | 113 | 16 | 110 | 22 | 113 | 16 | 110 | 22 | 113 |
| 20 | 16 | 110 | 22 | 113 | 16 | 110 | 22 | 113 | 16 | 110 | 22 | 113 | 16 | 110 | 22 | 113 | 16 | 110 | 22 | 113 |
| 25 | 16 | 110 | 22 | 113 | 16 | 110 | 22 | 113 | 16 | 110 | 22 | 113 | 16 | 110 | 22 | 113 | 12,5 | 108 | 18 | 111 |
| 31,5 | 16 | 110 | 22 | 113 | 16 | 110 | 22 | 113 | 16 | 110 | 22 | 113 | 12,5 | 108 | 18 | 111 | 10 | 106 | 14 | 109 |
| 40 | 16 | 110 | 22 | 113 | 16 | 110 | 22 | 113 | 12,5 | 108 | 18 | 111 | 10 | 106 | 14 | 109 | 8 | 104 | 11 | 107 |
| 50 | 16 | 110 | 22 | 113 | 12,5 | 108 | 18 | 111 | 10 | 106 | 14 | 109 | 8 | 104 | 11 | 107 | 6,3 | 102 | 8,9 | 105 |
| 63 | 12,5 | 108 | 18 | 111 | 10 | 106 | 14 | 109 | 8 | 104 | 11 | 107 | 6,3 | 102 | 8,9 | 105 | 5 | 100 | 7,1 | 103 |
| 80 | 10 | 106 | 14 | 109 | 8 | 104 | 11 | 107 | 6,3 | 102 | 8,9 | 105 | 5 | 100 | 7,1 | 103 | 4 | 98 | 5,6 | 101 |
| 100 | 8 | 104 | 11 | 107 | 6,3 | 102 | 8,9 | 105 | 5 | 100 | 7,1 | 103 | 4 | 98 | 5,6 | 101 | 3,2 | 96 | 4,5 | 99 |
| 125 | 6,3 | 102 | 8,9 | 105 | 5 | 100 | 7,1 | 103 | 4 | 98 | 5,6 | 101 | 3,2 | 96 | 4,5 | 99 | 2,5 | 94 | 3,6 | 97 |
| 160 | 5 | 100 | 7,1 | 103 | 4 | 98 | 5,6 | 101 | 3,2 | 96 | 4,5 | 99 | 2,5 | 94 | 3,6 | 97 | 2 | 92 | 2,8 | 95 |

Table 9.3.4

Vibration standards for turbo-compressors

| Geometric mean frequencies of 1/3-octave band, Hz | Permissible values of vibration rate | | | |
|--|--------------------------------------|-----|------------|-----|
| | category A | | category B | |
| | mm/s | dB | mm/s | dB |
| 1,6 | 10 | 106 | 14 | 109 |
| 2 | 12,5 | 108 | 16 | 110 |
| 2,5 | 14 | 109 | 20 | 112 |
| 3,2 | 20 | 112 | 25,5 | 114 |
| 4 | 24 | 114 | 34 | 116 |
| 5 | 24 | 114 | 34 | 116 |
| 6,3 | 24 | 114 | 34 | 116 |
| 8 | 24 | 114 | 34 | 116 |
| 10 | 24 | 114 | 34 | 116 |
| 12,5 | 24 | 114 | 34 | 116 |
| 16 | 24 | 114 | 34 | 116 |
| 20 | 24 | 114 | 34 | 116 |
| 25 | 24 | 114 | 34 | 116 |
| 31,5 | 24 | 114 | 34 | 116 |
| 40 | 24 | 114 | 34 | 116 |
| 50 | 24 | 114 | 34 | 116 |
| 63 | 24 | 114 | 34 | 116 |
| 80 | 24 | 114 | 34 | 116 |
| 100 | 24 | 114 | 34 | 116 |
| 125 | 24 | 114 | 34 | 116 |
| 160 | 24 | 114 | 34 | 116 |
| 200 | 24 | 114 | 34 | 116 |
| 250 | 18 | 111 | 26 | 116 |
| 320 | 14 | 109 | 20 | 112 |
| 400 | 11 | 107 | 16 | 110 |
| 500 | 9 | 106 | 13 | 109 |

9.4 VIBRATION STANDARDS FOR MAIN GEARED TURBINES AND THRUST BEARINGS

9.4.1 The running vibration of 15000 to 3000 kW horse power main geared turbines measured on the bearing housings is considered permissible for categories *A* and *B*, provided the root-means square values of vibration rate or vibration acceleration do not exceed the values specified in [Table 9.4.1](#).

The vibration standards specified in [Table 9.4.1](#), shall be applied to the main geared turbines when installed both on rigid and on yielding supports.

9.4.2 For main geared turbines of less than 15000 kW power the vibration standards are 3 dB lower than the values specified in [Table 9.4.1](#).

9.4.3 Vibration of thrust bearings shall not exceed the standards given in [9.4.1](#) and [9.4.2](#).

Table 9.4.1

Vibration standards for main geared turbines, thrust bearings, boilers, heat exchangers, ICE-driven generators, shaft-generators, turbo-drives, turbo-generators and piston compressors

| Geometric mean frequencies of 1/3-octave bands, Hz | Main geared turbines and trust bearings | | | | Boilers and heat exchangers | | | | ICE-driven generators, turbodrives and turbo-generators ¹ | | | | Piston compressors | | | |
|--|---|-----|------------|-----|-----------------------------|-----|------------|-----|--|-----|------------|-----|--------------------|-----|------------|-----|
| | Permissible values of vibration rate | | | | | | | | | | | | | | | |
| | category A | | category B | | category A | | category B | | category A | | category B | | category A | | category B | |
| | mm/s | dB | mm/s | dB | mm/s | dB | mm/s | dB | mm/s | dB | mm/s | dB | mm/s | dB | mm/s | dB |
| 1,6 | 1,5 | 90 | 2,5 | 94 | 3,5 | 97 | 5,6 | 101 | 1 | 86 | 1,6 | 90 | 2 | 92 | 3,2 | 96 |
| 2 | 1,9 | 92 | 3,1 | 96 | 3,5 | 97 | 5,6 | 101 | 1,3 | 88 | 1,9 | 92 | 2,5 | 94 | 4 | 98 |
| 2,5 | 2,4 | 94 | 3,8 | 98 | 3,5 | 97 | 5,6 | 101 | 1,5 | 90 | 2,4 | 94 | 3,1 | 96 | 5,1 | 100 |
| 3,2 | 3 | 96 | 4,8 | 100 | 4,4 | 99 | 7,1 | 103 | 1,9 | 92 | 3 | 96 | 4 | 98 | 6,4 | 102 |
| 4 | 3,7 | 97 | 6 | 102 | 5,6 | 101 | 8,9 | 105 | 2,3 | 93 | 3,7 | 97 | 5 | 100 | 8 | 104 |
| 5 | 4,6 | 99 | 7,5 | 104 | 7 | 103 | 11 | 107 | 2,9 | 95 | 4,6 | 99 | 6,2 | 102 | 10 | 106 |
| 6,3 | 5,7 | 101 | 9,3 | 105 | 8,8 | 105 | 14 | 109 | 3,6 | 97 | 5,7 | 101 | 7,9 | 104 | 12,5 | 108 |
| 8 | 7 | 103 | 11,5 | 107 | 10 | 106 | 16 | 110 | 4,5 | 99 | 7,1 | 103 | 10 | 106 | 16 | 110 |
| 10 | 8,8 | 105 | 14,5 | 109 | 10 | 106 | 16 | 110 | 5,6 | 101 | 8,9 | 105 | 10 | 106 | 16 | 110 |
| 12,5 | 11 | 107 | 18 | 111 | 10 | 106 | 16 | 110 | 7 | 103 | 11 | 107 | 10 | 106 | 16 | 110 |
| 16 | 11 | 107 | 18 | 111 | 10 | 106 | 16 | 110 | 7 | 103 | 11 | 107 | 10 | 106 | 16 | 110 |
| 20 | 11 | 107 | 18 | 111 | 10 | 106 | 16 | 110 | 7 | 103 | 11 | 107 | 10 | 106 | 16 | 110 |
| 25 | 11 | 107 | 18 | 111 | 10 | 106 | 16 | 110 | 7 | 103 | 11 | 107 | 10 | 106 | 16 | 110 |
| 31,5 | 11 | 107 | 18 | 111 | 10 | 106 | 16 | 110 | 7 | 103 | 11 | 107 | 10 | 106 | 16 | 110 |
| 40 | 11 | 107 | 18 | 111 | 10 | 106 | 16 | 110 | 7 | 103 | 11 | 107 | 10 | 106 | 16 | 110 |
| 50 | 8,8 | 105 | 14,5 | 109 | 8 | 104 | 12,5 | 108 | 7 | 103 | 11 | 107 | 10 | 106 | 16 | 110 |
| 63 | 7 | 103 | 11,5 | 107 | 6,3 | 102 | 10 | 106 | 7 | 103 | 11 | 107 | 7,9 | 104 | 12,5 | 108 |
| 80 | 5,7 | 101 | 9,3 | 105 | 5,2 | 100 | 8 | 104 | 7 | 103 | 11 | 107 | 6,2 | 102 | 10 | 106 |
| 100 | 4,6 | 99 | 7,5 | 104 | – | – | – | – | 5,6 | 101 | 8,9 | 105 | 5 | 100 | 8 | 104 |
| 125 | – | – | – | – | – | – | – | – | 4,5 | 99 | 7,1 | 103 | 4 | 98 | 6,4 | 102 |
| 160 | – | – | – | – | – | – | – | – | 3,6 | 97 | 5,7 | 101 | 3,1 | 96 | 5,1 | 100 |
| 200 | – | – | – | – | – | – | – | – | 2,9 | 95 | 4,6 | 99 | 2,5 | 94 | 4 | 98 |
| 250 | – | – | – | – | – | – | – | – | 2,3 | 93 | 3,7 | 97 | 2 | 92 | 3,2 | 96 |
| 320 | – | – | – | – | – | – | – | – | 1,9 | 92 | 3 | 96 | 1,6 | 90 | 2,5 | 94 |
| 400 | – | – | – | – | – | – | – | – | – | – | – | – | 1,3 | 88 | 2,1 | 92 |
| 500 | – | – | – | – | – | – | – | – | – | – | – | – | 1 | 86 | 1,6 | 90 |

¹ Refer to [9.5.4](#).

9.5 VIBRATION STANDARDS FOR AUXILIARY MACHINERY OF ROTARY TYPE

9.5.1 Vibration of vertical pumps with the capacity of 15 to 75 kW, including their electric drive, is assumed permissible for categories *A* and *B*, when the root-mean square values of vibration rate and vibration acceleration do not exceed the values stated in [Table 9.5.1](#).

Table 9.5.1

| Geometric mean frequencies of 1/3-octave bands, Hz | Pumps with the capacity of 15 to 75 kW | | | | Centrifugal separators | | | | Fans | | | |
|---|---|-----|-------------------|-----|------------------------|-----|-------------------|-----|-------------------|-----|-------------------|-----|
| | Permissible values of vibration rate | | | | | | | | | | | |
| | category <i>A</i> | | category <i>B</i> | | category <i>A</i> | | category <i>B</i> | | category <i>A</i> | | category <i>B</i> | |
| | mm/s | dB | mm/s | dB | mm/s | dB | mm/s | dB | mm/s | dB | mm/s | dB |
| 1,6 | 1 | 86 | 1 | 86 | 1 | 86 | 1,3 | 88 | 1 | 86 | 1,3 | 88 |
| 2 | 1 | 86 | 1,2 | 88 | 1 | 86 | 1,6 | 90 | 1 | 86 | 1,6 | 90 |
| 2,5 | 1,1 | 87 | 1,4 | 89 | 1,3 | 88 | 2 | 92 | 1,3 | 88 | 2 | 92 |
| 3,2 | 1,4 | 89 | 2 | 92 | 1,6 | 90 | 2,5 | 94 | 1,6 | 90 | 2,5 | 94 |
| 4 | 1,7 | 91 | 2,5 | 94 | 2 | 92 | 3,2 | 96 | 2 | 92 | 3,2 | 96 |
| 5 | 2,2 | 93 | 3,3 | 96 | 2,5 | 94 | 4 | 98 | 2,6 | 94 | 4 | 98 |
| 6,3 | 2,7 | 95 | 4 | 98 | 3,2 | 96 | 5 | 100 | 3,3 | 96 | 5 | 100 |
| 8 | 3,5 | 97 | 5 | 100 | 4 | 98 | 6,4 | 102 | 4,1 | 98 | 6,4 | 102 |
| 10 | 4,3 | 99 | 6,3 | 102 | 5 | 100 | 8 | 104 | 5,2 | 100 | 8 | 104 |
| 12,5 | 5,5 | 101 | 8 | 104 | 5 | 100 | 8 | 104 | 6,7 | 103 | 10,3 | 106 |
| 16 | 7 | 103 | 10 | 106 | 5 | 100 | 8 | 104 | 8,5 | 105 | 13 | 108 |
| 20 | 7 | 103 | 10 | 106 | 5 | 100 | 8 | 104 | 8,5 | 105 | 13 | 108 |
| 25 | 7 | 103 | 10 | 106 | 5 | 100 | 8 | 104 | 8,5 | 105 | 13 | 108 |
| 31,5 | 7 | 103 | 10 | 106 | 5 | 100 | 8 | 104 | 8,5 | 105 | 13 | 108 |
| 40 | 7 | 103 | 10 | 106 | 5 | 100 | 8 | 104 | 8,5 | 105 | 13 | 108 |
| 50 | 7 | 103 | 10 | 106 | 5 | 100 | 8 | 104 | 8,5 | 105 | 13 | 108 |
| 63 | 7 | 103 | 10 | 106 | 5 | 100 | 8 | 104 | 6,7 | 103 | 10,3 | 106 |
| 80 | 5,5 | 101 | 8 | 104 | 5 | 100 | 8 | 104 | 5,2 | 100 | 8 | 104 |
| 100 | 4,3 | 99 | 6,3 | 102 | 5 | 100 | 8 | 104 | 4,1 | 98 | 6,4 | 102 |
| 125 | 3,5 | 97 | 5 | 100 | 4 | 98 | 6,4 | 102 | 3,3 | 96 | 5 | 100 |
| 160 | 2,7 | 95 | 4 | 98 | 3,2 | 96 | 5 | 100 | 2,6 | 94 | 4 | 98 |
| 200 | 2,2 | 93 | 3,3 | 96 | 2,5 | 94 | 4 | 98 | 2 | 92 | 3,2 | 96 |
| 250 | 1,7 | 91 | 2,5 | 94 | 2 | 92 | 3,2 | 96 | 1,6 | 90 | 2,5 | 94 |
| 320 | 1,4 | 89 | 2 | 92 | 1,6 | 90 | 2,5 | 94 | 1,3 | 88 | 2 | 92 |
| 400 | – | – | – | – | 1,3 | 88 | 2 | 92 | 1 | 86 | 1,6 | 90 |
| 500 | – | – | – | – | 1 | 86 | 1,6 | 90 | 1 | 86 | 1,3 | 88 |

For pumps having the capacity of 2 to 15 kW the vibration standards for categories *A* and *B* are assumed being 3 dB lower compared with the vibration standards for the pumps having the capacity of 15 to 75 kW, and for the pumps with the capacity of 75 to 300 kW such standards shall be raised by 2 dB. Vibration standards for horizontal pumps for the above mentioned capacity range are assumed being 2 dB lower.

The vibration standards specified in [Table 9.5.1](#), shall be applied to all pumps when installed on rigid support. In case when the pumps are installed on yielding support, the permissible vibration standards shall be increased by 1,4 times for categories *A* and *B*.

9.5.2 Vibration of centrifugal separators is assumed permissible for categories *A* and *B*, when the root-mean square values of vibration rate and vibration acceleration do not exceed the values stated in [Table 9.5.1](#).

The vibration standards are specified considering the installation of separators on shock absorbers.

9.5.3 Vibration of fans and gas blowers of the inert gas systems is assumed permissible for categories *A* and *B*, when the root-mean square values of vibration rate and vibration acceleration do not exceed the values stated in [Table 9.5.1](#).

The vibration standards are specified considering the installation of fans and gas blowers on shock absorbers. In case of rigid fixing, these standards shall also be applied.

9.5.4 Vibration of turbo-drives, turbo-generators and generators of diesel-generators (ICE-driven generators) with the capacity of 1000 — 2000 kW, measured on the bearing housings, is assumed permissible for categories *A* and *B*, when the root-mean square values of vibration rate and vibration acceleration do not exceed the values stated in [Table 9.4.1](#).

For the turbo-drives, turbo-generators and generators of diesel-generators with the capacity under 1000 kW the vibration standards for categories *A* and *B* are by 4 dB lower than the values stated in [Table 9.4.1](#).

The vibration standards for turbo-drives and turbo-generators shall be applied when these are installed both on rigid and on yielding supports.

The vibration standards for generators of diesel-generators when installed on yielding supports shall be doubled.

9.6 VIBRATION STANDARDS FOR PISTON AIR COMPRESSORS

9.6.1 Vibration of piston air compressors is assumed permissible for categories *A* and *B*, when the root-mean square values of vibration rate and vibration acceleration do not exceed the values stated in [Table 9.4.1](#). When the compressor is mounted on the shock-absorbers, the vibration standards shall be raised by 4 dB.

9.7 VIBRATION STANDARDS FOR BOILERS AND HEAT EXCHANGERS

9.7.1 Vibration of boilers and heat exchangers is assumed permissible for categories *A* and *B*, when the root-mean square values of vibration rate and vibration acceleration do not exceed the values stated in [Table 9.4.1](#)

9.7.2 Vibration standards for auxiliary machinery and equipments, not covered by [9.5](#) and [9.6](#), shall be chosen based on [9.7.1](#).

9.8 VIBRATION STANDARDS FOR GEARED GAS TURBINES

9.8.1 Vibration of 250 to 25000 kW main geared gas turbines measured on the gas turbine supports and reduction gear bearings is considered permissible, provided the root-mean square values of vibration rate and vibration acceleration do not exceed the values stated in [Table 9.8.1](#).

Points of vibration measuring are shown in [Fig. 9.8.1](#).

Table 9.8.1

Vibration standards for geared gas turbines

| Geometric mean frequencies of 1/3-octave bands, Hz | Permissible values of vibration rate | | | | Geometric mean frequencies of 1/3-octave bands, Hz | Permissible values of vibration rate | | | |
|--|--------------------------------------|-----|------------|-----|--|--------------------------------------|-----|------------|-----|
| | category A | | category B | | | category A | | category B | |
| | mm/s | dB | mm/s | dB | | mm/s | dB | mm/s | dB |
| 1,6 | 1,6 | 90 | 2,9 | 96 | 125 | 8 | 104 | 16,5 | 110 |
| 2 | 1,8 | 91 | 3,5 | 97 | 160 | 8 | 104 | 16,5 | 110 |
| 2,5 | 2,2 | 93 | 4,3 | 98 | 200 | 8 | 104 | 16,5 | 110 |
| 3,2 | 2,7 | 95 | 5,3 | 100 | 250 | 8 | 104 | 16,5 | 110 |
| 4 | 3,2 | 96 | 7,0 | 103 | 320 | 8 | 104 | 16,5 | 110 |
| 5 | 4 | 98 | 9 | 105 | 400 | 8 | 104 | 16,5 | 110 |
| 6,3 | 5 | 100 | 11 | 107 | 500 | 8 | 104 | 16,5 | 110 |
| 8 | 6,7 | 103 | 13 | 108 | 640 | 6,5 | 102 | 12,5 | 108 |
| 10 | 8 | 104 | 16,5 | 110 | 800 | 4,8 | 100 | 10 | 106 |
| 12,5 | 8 | 104 | 16,5 | 110 | 1000 | 4 | 98 | 8 | 104 |
| 16 | 8 | 104 | 16,5 | 110 | 1280 | 3 | 96 | 7 | 103 |
| 20 | 8 | 104 | 16,5 | 110 | 1600 | 2,6 | 94 | 5 | 100 |
| 25 | 8 | 104 | 16,5 | 110 | 2000 | 2,1 | 92 | 3,9 | 98 |
| 31,5 | 8 | 104 | 16,5 | 110 | 2560 | 1,8 | 91 | 3 | 96 |
| 40 | 8 | 104 | 16,5 | 110 | 3200 | 1,5 | 90 | 2,4 | 95 |
| 50 | 8 | 104 | 16,5 | 110 | 4000 | 1 | 86 | 2 | 92 |
| 63 | 8 | 104 | 16,5 | 110 | 5120 | – | – | 1,7 | 91 |
| 80 | 8 | 104 | 16,5 | 110 | 6400 | – | – | 1,4 | 89 |
| 100 | 8 | 104 | 16,5 | 110 | 8000 | – | – | 1 | 86 |

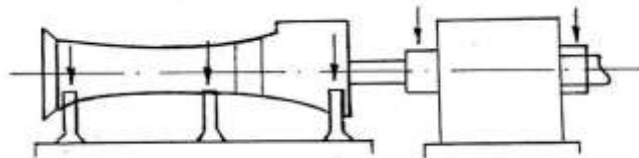

Fig. 9.8.1

Points of vibration measuring

(the points and directions of vibration measurement are shown by arrows)

9.8.2 Vibration standards for auxiliary gas turbines of less than 250 kW power shall be subject to special consideration by the Register and shall be submitted by the gas turbine manufacturer.

9.8.3 Vibration of gas-turbine-driven servo-machinery and devices shall not exceed the levels given in [9.8.1](#) and [9.8.2](#).

9.9 VIBRATION STANDARDS FOR MAIN AZIMUTH THRUSTERS

9.9.1 Vibration standards are extended to cover ICE- or electric motor driven main azimuth thrusters.

It is allowed to use vibration standards for auxiliary azimuth thrusters and athwartship thrusters.

The points and directions of vibration measuring are given in [Fig. 9.9.1](#).

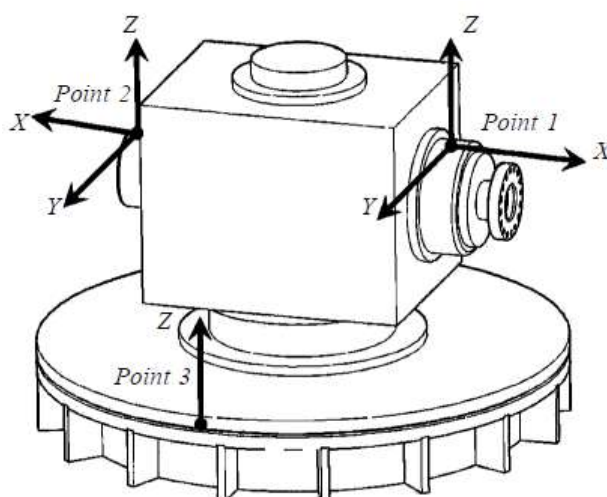

Fig. 9.9.1
Points of vibration measuring of main azimuth thrusters

9.9.2 Vibration of main azimuth thrusters is considered admissible for the categories as follows *A* and *B*, if the root-mean square values of vibration rate measured in the direction of axes *X*, *Y*, *Z* do not exceed the values in [Table 9.9.3](#).

9.9.3 Vibration of machinery and devices hung on main azimuth thrusters shall not exceed the levels listed in this Section for specified machinery and devices.

Table 9.9.3

| Geometric mean frequencies of 1/3-octave bands, Hz | Vibration standards of azimuth thrusters | | | |
|--|--|-----|------------|-----|
| | Category A | | Category B | |
| | mm/s | dB | mm/s | dB |
| 4 | 2,3 | 93 | 4,0 | 98 |
| 5 | 2,8 | 95 | 5,0 | 100 |
| 6,3 | 3,5 | 97 | 6,2 | 102 |
| 8 | 4,5 | 99 | 7,8 | 104 |
| 10 | 5,7 | 101 | 9,8 | 106 |
| 12,5 | 7,0 | 103 | 12,0 | 108 |
| 16 | 7,0 | 103 | 12,0 | 108 |
| 20 | 7,0 | 103 | 12,0 | 108 |
| 25 | 7,0 | 103 | 12,0 | 108 |
| 31,5 | 7,0 | 103 | 12,0 | 108 |
| 40 | 7,0 | 103 | 12,0 | 108 |
| 50 | 7,0 | 103 | 12,0 | 108 |
| 63 | 7,0 | 103 | 12,0 | 108 |

| Geometric mean frequencies of 1/3-octave bands, Hz | Category A | | Category B | |
|--|------------|-----|------------|-----|
| | mm/s | dB | mm/s | dB |
| 80 | 7,0 | 103 | 12,0 | 108 |
| 100 | 7,0 | 103 | 12,0 | 108 |
| 125 | 7,0 | 103 | 12,0 | 108 |
| 160 | 7,0 | 103 | 12,0 | 108 |
| 200 | 7,0 | 103 | 12,0 | 108 |
| 250 | 7,0 | 103 | 12,0 | 108 |
| 320 | 7,0 | 103 | 12,0 | 108 |
| 400 | 7,0 | 103 | 12,0 | 108 |
| 500 | 7,0 | 103 | 12,0 | 108 |
| 630 | 5,7 | 101 | 9,8 | 106 |
| 800 | 4,4 | 99 | 7,8 | 104 |
| 1000 | 3,5 | 97 | 6,2 | 102 |

10 TECHNICAL CONDITION MONITORING SYSTEMS

10.1 GENERAL

10.1.1 The requirements apply to condition monitoring and maintenance schemes for equipment in which state monitoring results determine the scope and/or frequency of surveys.

10.1.2 The schemes can be applied to the items located in the system of continuous survey of machinery, as well as to other items, considering the requirements of 2.8, Part II "Classification Surveys " of the Rules for Technical Supervision of Ships in Service¹.

¹ Hereinafter referred to as the Rules for TSSS.

10.2 GENERAL REQUIREMENTS FOR TECHNICAL CONDITION MONITORING SYSTEMS

10.2.1 The technical condition monitoring systems may be constructed on the basis of built-in (fixed) condition monitoring systems, portable control facilities or may combine both.

10.2.2 The built-in monitoring systems and their elements shall meet the requirements imposed on the ship automation systems (refer to Section 2, Part XV "Automation").

Failures in the operation of the built-in monitoring system shall not adversely affect the operation of the equipment.

10.2.3 The requirements for computers used in the technical condition monitoring systems are similar to the requirements of Section 7, Part XV "Automation".

10.2.4 The basic values of the diagnostic parameters used as initial (reference) data during the technical condition monitoring shall be obtained under the specific conditions of draught and the ship speed (at sea) and under operating conditions of the main engines and auxiliaries.

The basic data may be obtained on acceptance trials or on maiden voyage for a newbuilding or on another operational voyage under steady operating modes of the control items agreed with the Register.

RECOMMENDED LIST OF SPARE PARTS

Recognizing the complexity and diversity of machinery, equipment and systems providing essential services, a recommended list of spare parts may not always be relevant. In such circumstances, a risk-based approach shall be taken in order to determine the spare parts to be carried onboard. Such a risk-based approach is described in IACS Rec.26 for internal combustion engines, however, the approach described is equally relevant to other machinery, equipment and systems.

In cases where a risk assessment approach is not followed, [Tables 1 — 5](#) contain the list of recommended spare parts to the equipment supervised by the Register and essential to the propulsion and safety of the ship. The tables are not intended to replace any guidance provided by manufacturers or suppliers regarding recommended spare parts.

The spare parts shall be properly secured in easily accessible places, marked and efficiently protected against corrosion.

Table 1

List of minimum recommended spare parts for main internal combustion engines of ships for unrestricted service

| Nos. | Item | Spare part | Number recommended |
|------|-------------------------|---|--------------------|
| 1 | Main bearings | Main bearings or shells for one bearing of each size and type fitted, complete with shims, bolts and nuts | 1 |
| 2 | Main thrust block | Pads for one face of Michell type thrust block, or | 1 set |
| | | Complete white metal thrust shoe of solid ring type, or | 1 |
| | | Inner and outer race with rollers, where roller thrust bearings are fitted | 1 |
| 3 | Cylinder liner | Cylinder liner, complete with joint rings and gaskets | 1 |
| 4 | Cylinder cover | Cylinder cover, complete with valves, joint rings and gaskets | 1 |
| | | Cylinder cover bolts and nuts, for one cylinder | ½ set |
| 5 | Cylinder valves | Exhaust valves, complete with casings, seats, springs and other fittings for one cylinder | 2 sets |
| | | Air inlet valves, complete with casings, seats, springs and other fittings for one cylinder | 1 set |
| | | Starting air valve, complete with casting, seat springs and other fittings | 1 |
| | | Cylinder overpressure sentinel valve, complete | 1 |
| | | Fuel valves of each size and type fitted, complete with all fittings, for one engine | 1 set ¹ |
| 6 | Connecting rod bearings | Bottom end bearings or shells of each size and type fitted, complete with shims, bolts and nuts, for one cylinder | 1 set |
| | | Top end bearings or shells of each size and type fitted, complete with shims, bolts and nuts, for one cylinder | 1 set |
| 7 | Pistons | Crosshead type internal combustion engine; piston of each type fitted, complete with piston rod, stuffing box, skirt, rings, studs and nuts | 1 |
| | | Trunk piston type internal combustion engine: piston of each type fitted, complete with skirt, rings, studs, nuts, gudgeon pin and connecting rod | 1 |
| 8 | Piston rings | Piston rings, for one cylinder | 1 set |
| 9 | Piston cooling | Telescopic cooling pipes and fittings or their equivalent, for one cylinder unit | 1 set |
| 10 | Cylinder lubricators | Lubricator, complete, of the largest size, with its chain drive or gear wheels, or equivalent spare part kit | 1 |

| Nos. | Item | Spare part | Number recommended |
|------|---|---|--------------------|
| 11 | Fuel injection pumps | Fuel pump complete or, when replacement at sea is practicable, a complete set of working parts for one pump (plunger, sleeve, valves, springs, etc.), or equivalent high pressure fuel pump | 1 |
| 12 | Fuel injection piping | High pressure double wall fuel pipe of each size and shape fitted, complete with couplings | 1 |
| 13 | Scavenge blower (including turbochargers) | Rotors, rotor shafts, bearings, nozzle rings and gear wheels or equivalent working parts if other types | 1 set ² |
| 14 | Scavenging system | Suction and delivery valves for one pump of each type fitted | 1 set |
| 15 | Reduction and/or reverse gear | Complete bearing bush, of each size fitted in the gear case assembly | 1 set |
| | | Roller or ball race, of each size fitted in the gear case assembly | 1 set |
| 16 | Control, alarm and safety system | Parts essential for safe engine operation | 1 set |

¹ (a) Engines with one or two fuel valves per cylinder: one set of fuel valves, complete.
 (b) Engines with three or more fuel valves per cylinder: two fuel valves complete per cylinder, and a sufficient number of valve parts, excluding the body, to form, with those fitted in the complete valves, a full engine set.
² The spare parts may be omitted where it has been demonstrated, at the Builder's test bench for one engine of the type concerned, that the engine can be manoeuvred satisfactorily with one blower out of action. The requisite blanking and blocking arrangements for running with one blower out of action are to be available on board (refer to [2.1.7](#), Part VII "Machinery Installations").

Notes: 1. The availability of other spare parts, such as gears and chains for camshaft drive, should be specially considered and decided upon by the ship operator.
 2. It is assumed that the new crew has on board the necessary tools and equipment.
 3. When the recommended spares are utilized, it is recommended that new spares are supplied as soon as possible.
 4. In case of multi-engine installations, the minimum recommended spares are only necessary for one engine.

Table 2

List of minimum recommended spare parts for each part of auxiliary internal combustion engine driving electric generators for essential services on board ships for unrestricted service

| Nos. | Item | Spare part | Number recommended |
|------|-----------------------------|---|--------------------|
| 1 | Main bearings | Main bearings or shells for one bearing of each size and type fitted, complete with shims, bolts and nuts | 1 |
| 2 | Cylinder valves | Exhaust valves, complete with casings, seats, springs and other fittings for one cylinder | 2 sets |
| | | Air inlet valves, complete with casings, seats, springs and other fittings for one cylinder | 1 set |
| | | Starting air valve, complete with casing, seat springs and other fittings | 1 |
| | | Cylinder overpressure sentinel valve, complete | 1 |
| | | Fuel valves of each size and type fitted, complete with all fittings, for one engine | ½ set |
| 3 | Connecting rod set bearings | Bottom end bearings or shells of each size and type fitted, complete with shims, bolts and nuts, for one cylinder | 1 set |
| | | Trunk piston internal combustion engine type: gudgeon pin with bush for one cylinder | 1 set |
| 4 | Piston rings | Piston rings, for one cylinder | 1 set |
| 5 | Piston cooling | Telescopic cooling pipes and fittings or their equivalent, for one cylinder | 1 set |
| 6 | Fuel injection pumps | High pressure double wall fuel pipe of each size and shape fitted, complete with couplings | 1 |

| Nos. | Item | Spare part | Number recommended |
|------|----------------------------------|---|--------------------|
| 7 | Fuel injection piping | High pressure double wall fuel pipe of each size and shape fitted, complete with couplings | 1 |
| 8 | Gaskets and Packings | Special gaskets and packings of each size and type fitted, for cylinder covers and cylinder liners for one cylinder | 1 set |
| 9 | Control, alarm and safety system | Parts essential for safe engine operation | 1 set |

Notes: 1. The availability of other spare parts should be specially considered and decided upon by the ship operator.
 2. It is assumed that the crew has on board the necessary tools and equipment.
 3. When the recommended spares are utilized, it is recommended that new spares are supplied as soon as possible.
 4. Where the number of generators of adequate capacity fitted for essential services exceeds the required number, spare parts may be omitted.

Table 3

List of minimum recommended spare parts for each steam turbines driving electric generators for essential services of ships for unrestricted service

| Nos. | Item | Spare part | Number recommended |
|------|----------------------------------|--|--------------------|
| 1 | Turbine shaft | Carbon sealing rings, where fitted, with springs, for each size and sealing rings type of gland, for one turbine | 1 set |
| 2 | Oil filters | Strainer baskets or inserts, for filters of special design, of each type and size | 1 set |
| 3 | Control, alarm and safety system | Parts essential for safe turbine operation | 1 set |

Notes: 1. The availability of other spare parts shall be specially considered and decided upon by the ship operator.
 2. It is assumed that the crew has on board the necessary tools and equipment.
 3. When the recommended spares are utilized, it is recommended that new spares are supplied as soon as possible.
 4. Where the number of generators of adequate capacity fitted for essential services exceeds the required number, spare parts

Table 4

List of minimum recommended spare parts for main steam turbines of ships for unrestricted service

| Nos. | Item | Spare part | Number recommended |
|------|----------------------------------|--|--------------------|
| 1 | Turbine shaft | Carbon sealing rings, where fitted, with springs for each size sealing rings and type of gland | 1 set |
| 2 | Oil filters | Strainer baskets or inserts for filters of special design, of each type and size | 1 set |
| 3 | Control, alarm and safety system | Parts essential for safe turbine operation | 1 set |

Notes: 1. The availability of other spare parts should be specially considered and decided upon by the ship operator.
 2. It is assumed that the crew has on board the necessary tools and equipment.
 3. When the recommended spares are utilized, it is recommended that new spares are supplied as soon as possible.

Table 5

List of minimum recommended spare parts
for essential auxiliary machinery of ships for unrestricted service

| Nos. | Item | Spare part | Number recommended |
|---|-------------------|--|--------------------|
| Pumps | | | |
| 1 | Piston pumps | Valve with seats and springs, each size fitted | 1 set |
| | | Piston rings, each type and size for one piston | 1 set |
| 2 | Centrifugal pumps | Bearing of each type and size | 1 |
| | | Rotor sealings of each type and size | 1 |
| 3 | Gear type pumps | Bearing of each type and size | 1 |
| | | Rotor sealings of each type and size | 1 |
| Notes: | | | |
| 1. When a sufficiently rated standby pump is available, the spare parts may be dispensed with. | | | |
| 2. It is recommended that where, for maintenance or repair work of the pumps, special tools or equipment shall be used, these are available on board. | | | |
| 3. When the recommended spares are utilized, it is recommended that new spares are supplied as soon as possible. | | | |
| Compressors | | | |
| 1 | Valves | Suction and delivery valves complete of each size fitted in one unit | ½ set |
| 2 | Pistons | Piston rings of each type and size fitted for one piston | 1 set |
| Notes: | | | |
| 1. It is recommended that where, for maintenance or repair work of the compressors, special tools or equipment shall be used, these are available on board. | | | |
| 2. When the recommended spares are utilized, it is recommended that new spares are supplied as soon as possible. | | | |

SPECIAL APPROVAL OF ALLOY STEEL FOR INTERMEDIATE SHAFT MATERIAL**1 APPLICATION****1.1 General.**

1.1.1 The requirements apply to the approval of alloy steel which has a minimum specified tensile strength greater than 800 MPa, but less than 950 MPa intended for use as intermediate shaft material.

1.1.2 The Section contains the main data on the steel fatigue evaluation by means of torsional fatigue testing. The purpose of the torsional fatigue test shall be meeting the requirements to the torsional fatigue to be equal to the intermediate shaft material, specified in the corresponding Sections of these Rules given by the formulae. The torsional fatigue strength of said material is to be equal to or greater than the permissible torsional vibration stress τ_c given by [Formulae 8.3.1](#).

1.1.3 The chemical composition for forgings shall meet the minimum requirements specified in Table 3.7.2.3-2, Part XIII "Materials", considering the content of sulphur, phosphorus and oxygen. The chemical composition, structures and mechanical properties shall meet the minimum requirements of Part XIII "Materials" and shall be submitted to the Register for consideration.

2 CARRYING OUT OF TESTS

2.1 The tests shall be carried out with notched and unnotched specimens respectively. For calculation of the stress concentration factor of the notched specimen, fatigue strength reduction factor β shall be evaluated in consideration of the severest torsional stress concentration in the design criteria. Mean surface roughness shall be $<0,2\mu\text{m Ra}$ with the absence of localized machining marks verified by visual examination at low magnification (x 20) before 1 July 2022 as required by Section 8.4 of ISO 1352, and on and after 1 July 2022 according to Section 8.4 ISO 1352:2011. Test procedures shall be in accordance with Section 10 of ISO 1352 before 1 July 2022 and in accordance with Section 10 of ISO 1352:2011 on and after 1 July 2022.

2.2 Test conditions shall be in accordance with [Table 1](#).

Table 1

| | |
|------------------------------------|---------------------------------|
| Loading type | Torsion |
| Stress ratio | $R = 1$ |
| Load waveform | Constant – amplitude sinusoidal |
| Evaluation | S-N curve |
| Number of cycles for test terminal | 1×10^7 |
| Specimens | Notched and unnotched |

2.3 The steels shall have a degree of cleanliness as shown in [Table 2](#) when tested according to ISO 4967 method A before 1 July 2022, and according to ISO 4967:2013 method A on and after 1 July 2022. Representative samples shall be obtained from each heat of forged or rolled products. The samples shall be subject to ultrasonic testing required by 3.7.7.2 Part XIII "Materials" prior to acceptance.

From 1 July 2022 the steels shall have a degree of cleanliness as shown in [Table 2](#) when tested according to ISO 4967:2013 method A. Representative samples shall be obtained from each heat of forged or rolled products. The samples shall be subject to ultrasonic testing required by 3.7.7.2 Part XIII "Materials" prior to acceptance.

Table 2

| | | |
|----|-------|-----|
| A | Fine | 1 |
| | Thick | 1 |
| B | Fine | 1,5 |
| | Thick | 1 |
| C | Fine | 1 |
| | Thick | 1 |
| D | Fine | 1 |
| | Thick | 1 |
| DS | – | 1 |

3 ACCEPTANCE CRITERIA

Total stresses shall be equal to or greater than the values given by the following formulae:
For measured high-cycle torsional fatigue strength τ_{C1}

$$\tau_{C1} \geq \tau_C \frac{\sigma_B + 160}{6} C_K C_D \quad (1-1)$$

For low-cycle torsional fatigue strength τ_{C2} :

$$\tau_{C2} \geq 1,7 \frac{1}{\sqrt{C_K}} \tau_{C1}, \quad (1-2)$$

where: τ_C – permissible amplitude of stress in MPa in the sample due to torsional vibration for continuous operation (refer to [8.3.1](#) and addition [8.3.1-1](#));
 σ_B – specified minimum tensile strength in MPa of the shaft material;
 C_K – factor for the particular shaft design features; when selecting stress concentration factor, scf , (for calculating C_K for unnotched specimen, $scf = 1$ (refer to [Table 8.3.1](#));
 C_D – size factor (refer to [8.2.1](#)).

RECOMMENDATIONS FOR TECHNICAL CONDITION MONITORING SYSTEMS

1 DIAGNOSTIC PARAMETERS

- 1.1** Diagnostic parameters shall specify the technical condition of the item.
- 1.2** Measuring time intervals of diagnostic parameters shall ensure the reliability of determining the technical condition of the monitoring item.
- 1.3** The measurement results and the prediction of diagnostic parameters shall be stored in a form convenient for their analysis.
- 1.4** The maximum permissible values of the diagnostic parameters shall be determined.

2 RECOMMENDATIONS FOR MONITORING INDICATORS OF WORKING FLUIDS

- 2.1** For each type of equipment, the applicable brands of liquids shall be indicated, the frequency, locations and sampling methods for analysis shall be determined. The nomenclature of specifications and rejection values of indicators of the analyzed fluids are set by the developer of the monitoring system.

3 REQUIREMENTS FOR CONTROL OF THE DIESEL ENGINE WORKING PROCESS PARAMETERS

- 3.1** The requirements apply to the equipment for measuring pressure in the engine cylinder and fuel supply parameters.
- 3.2** To process the measurement results of the working process parameters, use is also made of the parameters measured in the alarm system. In this case, interference shall not be introduced into the operation of the alarm system.
- 3.3** The Register shall be given specifications of sensors, measuring equipment and measurement results processing program (including list of calculated parameters and method of presentation thereof).
- 3.4** The electronic unit used for measurement of the working process parameters shall have dynamic characteristics providing for the measurement of the maximum gas pressure in cylinder.
- 3.5** Measurement of the pressure in cylinder and fuel supply parameters with the use of the sensors presented is allowed to be made not on all cylinders simultaneously, but for all that the steady operating conditions of the diesel engine shall be maintained.
- 3.6** The equipment for measurement, processing and presentation of the cylinder pressure curve (indicator diagram) and the fuel supply characteristics shall provide for the analysis thereof with a resolution of not less than one degree of the crankshaft rotation.
- 3.7** The indicator diagram processing program shall calculate for each cylinder:
- mean indicated pressure;
 - cylinder indicated power;
 - maximum cylinder combustion pressure;
 - maximum compression pressure;
 - pressure on compression line at point 12° before the top dead centre (TDC);
 - pressure on expansion line at point 36° after the TDC;

the crankshaft rotation angle corresponding to the maximum combustion pressure; ignition advance angle.

3.8 The fuel supply parameters processing program shall determine:

fuel injection beginning;

fuel injection time angle;

maximum fuel pressure.

3.9 The processing program shall provide for comparison of the loading in cylinders. Permissible deviations of the working process parameters from the average over the cylinders:

mean indicated pressure – not more than $\pm 2,5$ %;

maximum combustion pressure – not more than $\pm 3,5$ %;

compression end pressure – $\pm 2,5$ %.

The cited values of the combustion pressure in any cylinder shall not be less than 85 % of the value obtained on basic tests.

The results of basic tests are considered to mean the results of the acceptance tests of the diesel engine on board or special tests on operational voyage).

4 REQUIREMENTS FOR CONTROL OF WEAR PARAMETERS OF THE ENGINE CYLINDER AND PISTON ASSEMBLY

4.1 The parameter, which defines the engine cylinder and piston assembly condition (its wear), is the tightness of the combustion chamber.

4.2 The tightness of the combustion chamber is measured by a special instrument: pneumoindicator, which is a flow-metering device set at a particular cylinder diameter.

4.3 The methods for determination of the cylinder tightness and the standards for the cylinder and piston assembly condition shall be presented by the system developer.

5 REQUIREMENTS FOR CONTROL OF VIBRATION PARAMETERS

5.1 For the purpose of the machinery vibration condition monitoring, use shall be made of the following equipment, which provides for the measurement and processing of the vibration parameters: root-mean-square values of vibration rate or vibration acceleration in 1/3-octave band and in octave band, and the data analysis in temporal area:

vibrometers-analyzers;

vibration diagnosis systems performing measurement, processing, storage and spectrum analysis of the vibration parameters.

5.2 The requirements for the installation and attachment of the vibration pickup on the controlled item shall be provided. The preference shall be given to attachment of the pickup by a pin (screw). To realize such attachment method, pins shall be fitted beforehand at all measurement points. The vibration pickups may be installed on a magnet. Where the vibration pickups cannot be installed using a pin or magnet, manual vibration pickups may be used.

5.3 For each machinery, points and directions for measuring vibration parameters shall be indicated.

The manufacturers' recommendations shall be used. Where no such recommendations are available, type lay-out diagrams of the machinery vibration measurement points shall be taken as a guide (refer to [9.2.5](#)).

For the vibration condition monitoring, measurement may be restricted to one or two directions on one most loaded machinery bearing.

Note. For units consisting of a machinery and its driving unit (pump and electric motor, fan and electric motor), measurements are made on one machinery bearing and one motor bearing on the coupling side. When exercising control of the separator vibration condition, measurements shall be made in two radial directions on both motor bearings and in three directions on the separator bowl bearing.

6 REQUIREMENTS FOR CONTROL OF THE SHOCK PULSE

6.1 The condition of the roller bearings is assessed by a shock pulse method. The controlled machinery manufacturer, developer or supplier of the technical condition monitoring system may propose another method of roller bearing condition assessment. In this case, the proposed method shall be approved by the Register.

6.2 The instrument for control of the roller bearing condition shall be fitted with a built-in calibrator to verify precision of readings.

6.3 The measurement methods shall make it possible to separate the values of shock pulses arising due to the roller bearing against the background of the signals from other sources. The methods shall establish positions for other measurements to be made on the bearing housing on the basis of the maximum shock pulse value or contemplate special devices measuring bolts, where there is no direct access to the bearing housing.

6.4 The shock pulse standards defining lubrication condition and roller bearing damages shall be presented by the manufacturer of the technical condition monitoring system.

7 RECOMMENDATIONS FOR PREDICTION OF TECHNICAL CONDITION

7.1 The controlled item condition is predicted for the forthcoming time period between annual surveys. The prediction is made either on the basis of the past history of the parameters defining condition or on the basis of the known rate of the parameter change. On completion of the measurement, the prediction shall be adjusted.

7.2 Based on the prediction results, the frequency of the condition control may be changed. If the prediction results indicates that the limiting values of the controlled parameters can be attained, the intervals between the measurements shall be reduced, the causes of the condition degradation established and the maintenance planned.

7.3 If the item condition is described by the several independent parameters, prediction shall be made for each parameter. In this case, maintenance becomes necessary when any of the parameters to be predicted reaches the limiting value.

Russian Maritime Register of Shipping

Rules for the Classification and Construction of Sea-Going Ships
Part VII
Machinery Installations

FAI "Russian Maritime Register of Shipping"
7, Litera A, Millionnaya Ulitsa,
St. Petersburg, 191186
Russian Federation
www.rs-class.org/en/